

PIAZZA

CATALOGO CATALOGUE
2026 2027



LEGENDA CATALOGO

CATALOGUE KEY



Quando la singola confezione contiene più pezzi è presente questo simbolo
When the single pack contains more pieces there is this symbol

Beccuccio versatore "Versus"
"Versus" pouring spout

| Cod. | Col. | Box |
|----------|------|-----|
| 50100112 | | 4 |
| 50100312 | | 4 |
| 50100412 | | 4 |
| 50100612 | | 4 |

| CONFEZIONAMENTO DEL PRODOTTO PRODUCT PACKAGING | CODICE PRODOTTO ITEM NUMBER | INFO PRODOTTO Dimensioni, colore, capacità, ecc. PRODUCT INFO Sizes, colour, capacity, etc. | MULTIPLIO DI VENDITA Se non indicato si intende un pezzo singolo BOX QUANTITY If not stated just one piece |
|---|--------------------------------|--|---|
| | | | |

SIMBOLI CONFEZIONAMENTO PRODOTTI PRODUCTS PACKAGING SYMBOLS

| | | | |
|--|--|------------------------------------|--|
| SCATOLA BOX | SCATOLA APPENDIBILE HANGING BOX | SACCHETTO BAG | SACCHETTO APPENDIBILE HANGING BAG |
| CARTONCINO APPENDIBILE HANGING CARD | BLISTER SKINPACK | TERMORETRAIBILE SHRINK WRAP | VARIABILE VARIABLE |

SIMBOLI UTILIZZO PENTOLAME POTS AND PANS SYMBOLS

| | | | |
|---------|------------------------------|----------------------------|----------------------------|
| GAS | VETROCERAMICA CERAMIC | ELETTRICO HOTPLATES | INDUZIONE INDUCTION |
|---------|------------------------------|----------------------------|----------------------------|

I MATERIALI THE MATERIALS

| Acciaio inox | Stainless steel | Stahl | Inox | Inox |
|------------------------|--------------------|-----------------------------------|-------------------------------|-------------------------------|
| Alluminio | Aluminum | Aluminium | Aluminium | Aluminio |
| Alluminio anodizzato | Anodized aluminum | Aluminium anodisiert | Alu anodisé | Aluminio anodizado |
| Alluminio oxalizzato | Oxalized aluminum | Aluminium eloxiert | Alu éloxé | Aluminio oxalizado |
| Alluminio antiaderente | Non-stick aluminum | Aluminium mit Antihafbeschichtung | Aluminium antiadhésif | Aluminio antiadherente |
| Alluminio pressofuso | Die-cast aluminum | Druckgussaluminium | Aluminium moulé sous pression | Aluminio fundido bajo presión |
| Banda stagnata | White latten | Blech | Fer étamé | Banda estañada |
| Caucciù | Rubber | Kautschuk | Caoutchouc naturel | Caucho |
| Ceramica | Ceramic | Ton | Céramique | Cerámica |
| Cotone | Cotton | Baumwolle | Coton | Algodón |
| Ferro Bianco | White Iron | Weiss eisen | Fer blanc | Hierro blanco |
| Ferro Blu | Blue steel | Blau Blech | Fer bleu | Hierro azul |
| Fibra di vetro | Fiberglass | Fiberglas | Fibre de verre | Fibra de vidrio |
| Gomma | Rubber | Gummi | Caoutchouc | Goma |
| Latta | Tin | Blech | Fer Blanc | Hojalata |
| Legno | Wood | Holz | Bois | Madera |
| Melamina | Melamin | Melamin | Mélamine | Melamina |
| Ottone | Brass | Messing | Laton | Latón |
| Pelle ovina | Kid leather | Olivinleder | Cuir de boeuf | Piel ovina |
| Plastica | Plastic | Plastik | Plastique | Plástico |
| Poliamide | Polyamide | Polyamid | Polyamide | Poliàmida |
| Policarbonato | Polycarbonate | Polikarbonat | Polycarbonate | Policarbonato |
| Polietilene | Polyethylene | Polyäthlen | Polyéthlene | Poliètilènc |
| Polipropilene | Polypropylene | Polypropylen | Polypropylène | Polipropilènc |
| Porcellana | Porcelain | Porzellan | Porcelaine | Porcelana |
| Propilene | Propylene | Propylen | Propylène | Propilènc |
| Rame | Copper | Kupfer | Culvre | Cobre |
| Resina | Resin | Harz | Résine | Resina |
| Silicone | Silicone | Silikon | Silicone | Silicona |
| Vetro | Glass | Glas | Verre | Vidrio |



PIAZZA

CATALOGO CATALOGUE 2026 2027

| | | |
|--------------------|-------------|-----|
| ACCESSORI | ACCESSORIES | 11 |
| CUCINA | COOKWARE | 31 |
| PIZZERIA | | 85 |
| PASTICCERIA | PÂTISSERIE | 113 |
| TAVOLA | TABLEWARE | 137 |
| BAR | | 151 |

UNA STORIA DI QUALITÀ E DI ATTACCAMENTO AL NOSTRO TERRITORIO

HISTORY OF QUALITY AND CONNECTION WITH OUR LAND



NASCE IL NUOVO STABILIMENTO SULLO STESSO LUOGO DEL VECCHIO E INIZIA LA SPECIALIZZAZIONE NEL SETTORE HO.RE.CA.

THE NEW PLANT IS BUILT ON THE SAME SITE OF THE OLD ONE AND IT STARTS FOCUSING ON PROFESSIONAL KITCHEN TOOLS

1880



I FRATELLI GIUSEPPE E BALDASSARRE PIAZZA FONDANO L'AZIENDA

THE COMPANY WAS FOUNDED BY THE BROTHERS GIUSEPPE AND BALDASSARRE PIAZZA

1970

GIANNI PIAZZA BREVETTA IL PRIMO PORZIONATORE IN ACCIAIO INOX. È SOLO UNO DEI TANTI BREVETTI DI QUEGLI ANNI

GIANNI PIAZZA PATENTS THE FIRST ICE-CREAM SCOOP MADE OF STAINLESS STEEL. IT'S JUST ONE OF THE MANY PATENTS OF THOSE YEARS

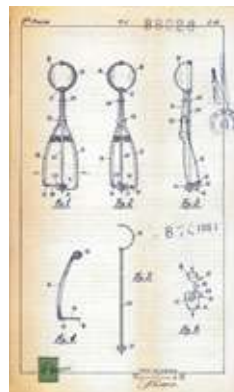

1961



1906

DOPO POCHI ANNI DI VITA PIAZZA È GIÀ ATTIVA SUI PRIMI MERCATI DELL'ERA MODERNA

AFTER A FEW YEARS PIAZZA IS ALREADY ACTIVE ON THE FIRST MARKETS OF THE MODERN ERA

1930

COMINCIA IL PASSAGGIO DA LABORATORIO FAMILIARE A MODERNA INDUSTRIA

THE TRANSITION FROM FAMILY WORKSHOP TO MODERN MANUFACTURING COMPANY BEGINS



ANCHE IL SECONDO STABILIMENTO DIVENTA OPERATIVO

ALSO THE SECOND PLANT GETS OPERATIONAL



2004



IL LANCIO DELLA LINEA "HAPPY HOUR" RIVOLUZIONA IL MONDO DEL BARTENDING. DAL 2006 AL 2021 PIAZZA DIVENTA SPONSOR TECNICO DI ALMA, LA SCUOLA INTERNAZIONALE DI CUCINA ITALIANA

THE LAUNCH OF THE 'HAPPY HOUR' LINE TRANSFORMS THE WORLD OF BARTENDING. FROM 2006 TO 2021 PIAZZA BECOMES TECHNICAL SPONSOR OF ALMA, THE SCHOOL OF ITALIAN CULINARY ARTS

1990

2021



NASCE LA NUOVA COLLEZIONE PIZZERIA "PUNTOROSSO", 100% MADE IN ITALY

THE NEW PIZZERIA RANGE IS LAUNCHED ON THE MARKET. 'PUNTOROSSO' COLLECTION: 100% MADE IN ITALY

LA COLLEZIONE PIZZERIA SI AMPLIA CON LA NUOVA LINEA "BLUE DROP"

THE PIZZERIA RANGE EXPANDS WITH THE NEW 'BLUE DROP' LINE



2025

OGGI PIAZZA È UN'AZIENDA PRONTA AD AFFRONTARE LE SFIDE DI UN MERCATO IN RAPIDA E COSTANTE EVOLUZIONE

TODAY PIAZZA IS A COMPANY READY TO FACE THE CHALLENGES OF A RAPIDLY AND CONSTANTLY EVOLVING MARKET

2 SEDI PRODUTTIVE
MANUFACTURING UNITS

13.500 M² DI SUPERFICIE TOTALE
OF TOTAL SURFACE

200 M² IL NOSTRO PUNTO VENDITA
OUR STORE & OUTLET

7 AGENTI IN ITALIA
AGENTS IN ITALY

360 DISTRIBUTORI IN ITALIA
DISTRIBUTORS IN ITALY

5 AGENTI NEL MONDO
AGENTS WORLDWIDE

150 DISTRIBUTORI NEL MONDO
DISTRIBUTORS WORLDWIDE

+50 I PAESI NEL MONDO IN CUI VENDIAMO
COUNTRIES WHERE WE OPERATE



INVENTIAMO, PROGETTIAMO, PRODUCIAMO. SEMPRE QUI, DOVE SIAMO NATI!

WE INVENT, WE DESIGN, WE MANUFACTURE.
ALWAYS HERE, WHERE WE WERE BORN!

1

ASCOLTIAMO I PROFESSIONISTI, NE INTERPRETIAMO LE NECESSITÀ E CERCHIAMO DI CAPIRE LE LORO ESIGENZE

WE LISTEN TO PROFESSIONALS, INTERPRET THEIR REQUESTS AND TRY TO FULFILL THEIR NEEDS

2

TRADUCIAMO SUGGERIMENTI E CONSIGLI IN UN'IDEA DI PRODOTTO, IN GRADO DI SODDISFARE LE ASPETTATIVE DI CHI LO USERÀ

WE TURN TIPS AND ADVICES INTO A PRODUCT IDEA, THAT CAN MEET USERS' EXPECTATIONS

3

I DESIGNER CHE PROGETTANO PER PIAZZA DANNO FORMA ALLA NOSTRA IDEA TRADUCENDOLA IN UN PRODOTTO REALE

THE DESIGNERS WHO WORK FOR PIAZZA GIVE SHAPE TO OUR IDEA RESULTING IN A PROJECT

4

CON LA STAMPA 3D VIENE REALIZZATO UN PROTOTIPO IN MISURA REALE, SUL QUALE SI FANNO LE PRIME VERIFICHE RELATIVE A FORMA E FUNZIONALITÀ

WE CREATE A REAL SIZE PROTOTYPE, WITH 3D PRINTING, TO MAKE THE FIRST CHECKS ON SHAPE AND FUNCTIONALITY

5

IL NOSTRO UFFICIO RICERCA E SVILUPPO INGEGNERIZZA IL PRODOTTO E REALIZZA I DISEGNI DEFINITIVI PER LA CREAZIONE DEGLI STAMPI

R&D DEPARTMENT ENGINEERS THE PRODUCT AND CREATES THE FINAL DRAWINGS TO MAKE THE MOLDS

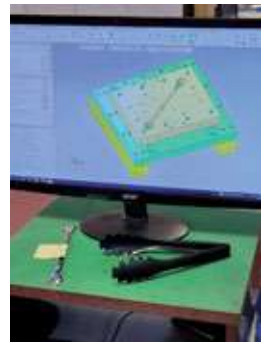

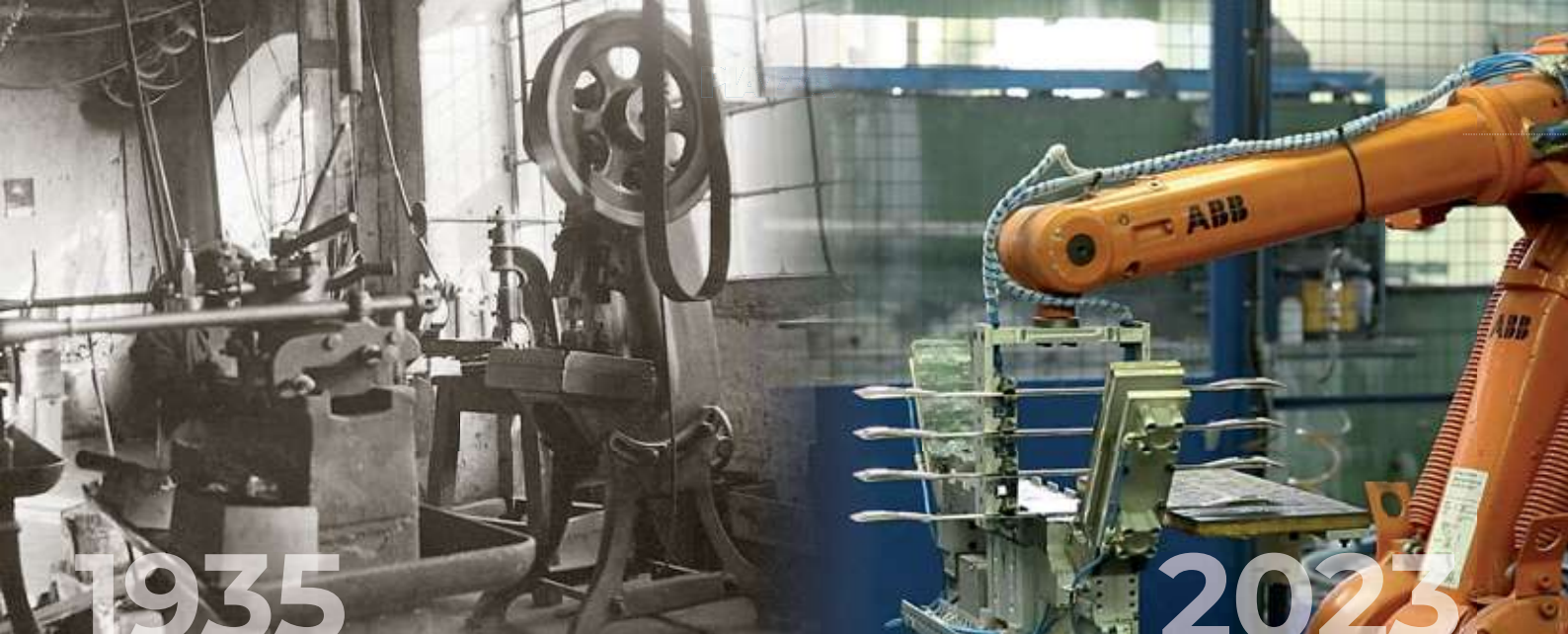

6

VENGONO FATTI GLI STAMPI CHE SERVIRANNO PER LA PRODUZIONE DEFINITIVA

WE MAKE THE MOLDS FOR THE FINAL PRODUCTION

7

PRIMA DI ESSERE MESSO IN COMMERCIO IL PRODOTTO VIENE ACCURATAMENTE TESTATO PER ESSERE CERTI DELLA SUA QUALITÀ

BEFORE BEING PUT ON THE MARKET, THE PRODUCT IS CAREFULLY TESTED TO BE SURE OF ITS QUALITY

8

IL PRODOTTO FINITO VIENE "VESTITO" CON IL PACKAGING E IMMESSO SUL MERCATO

THE FINISHED PRODUCT IS 'FINALIZED' WITH THE PACKAGING AND FINALLY LAUNCHED ON THE MARKET

9

SI RACCOLGONO I FEEDBACK, SIA POSITIVI CHE NEGATIVI, IN MERITO AL PRODOTTO E A TUTTE LE SUE CARATTERISTICHE

WE COLLECT THE FEEDBACK, BOTH POSITIVE AND NEGATIVE, REGARDING THE PRODUCT AND ALL ITS CHARACTERISTICS

10

CONTINUIAMO A LAVORARE SUL PRODOTTO PER MIGLIORARLO, PERFEZIONARLO E RENDERLO SEMPRE PIÙ VICINO AI BISOGNI DI CHI LO UTILIZZA

WE CONTINUE TO WORK ON THE PRODUCT TO IMPROVE IT, PERFECT IT AND MAKE IT CLOSER TO USERS' NEEDS

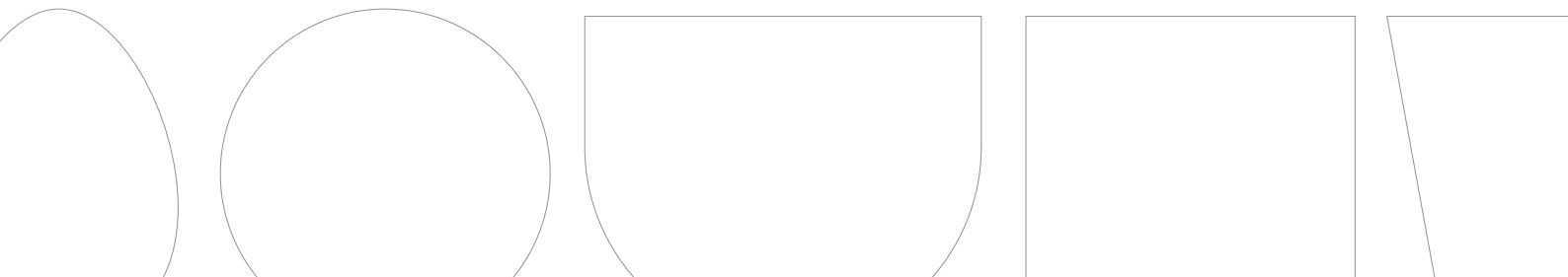

CON VOI OVUNQUE VOGLIATE, PER FARVI SENTIRE SEMPRE IN BUONE MANI.

WITH YOU WHEREVER YOU WANT,
TO MAKE YOU ALWAYS FEEL IN BUONE MANI*

Grazie alla nuova veste del nostro sito web www.piazza.it potete consultare, in qualunque momento e dovunque voi siate, l'intero nostro catalogo.

L'abbiamo pensato per rendere la vostra ricerca facile e veloce, secondo quell'idea di massima funzionalità che è il tratto caratteristico di tutti i nostri prodotti.

Inoltre, grazie ai nostri canali social, resterete sempre aggiornati in tempo reale su novità ed eventi.

Thanks to the new look of our website www.piazza.it you can browse our entire catalog everytime and everywhere.

Its design allows a quick and easy search. Being functional is the central idea for both our communication tools and products.

Moreover, thanks to our social channels, you will always have real-time updates on news and events.



INQUADRA
IL QR CODE
E SCOPRI IL
NOSTRO SITO
SCAN THE
QR CODE
AND DISCOVER
OUR WEBSITE



* The expression 'in buone mani' (translatable as 'in good hands') is a common Italian saying to reassure and make you feel sure about the quality, reliability, safety of a product or service

DESIDERATE UN PRODOTTO PERSONALIZZATO? LO POSSIAMO FARE!

DO YOU WISH A PERSONALIZED PRODUCT? WE CAN DO IT!

Siamo, da sempre, un'azienda di produzione attenta ai bisogni dei propri clienti.

È per questo che vogliamo offrire loro la possibilità di personalizzazione dei nostri prodotti con il logo o altri elementi. Anche il packaging, in base ai quantitativi, può essere personalizzato con la grafica fornita dal cliente.

Possiamo farlo in tempi rapidi e con la massima versatilità, grazie all'esperienza e alla passione delle persone che lavorano in PIAZZA.

Per saperne di più: piazza@piazza.it

We have always been a manufacturing company who cares about the needs of its customers.

That's why we want to offer them too the possibility of personalizing our products with their logo or other elements.

Even the packaging, based on the quantities, can be customized with graphics supplied by the customer.

We can do it quickly and with maximum versatility, thanks to experience and passion of the people who work in PIAZZA.

To know more: piazza@piazza.it



COLLABORARE CON I PROFESSIONISTI, IL NOSTRO "INGREDIENTE" PER MIGLIORARCI DI CONTINUO

COOPERATE WITH PROFESSIONALS,
OUR 'INGREDIENT' TO CONTINUOUSLY IMPROVE

Amiamo raccontare i nostri prodotti attraverso le mani sapienti dei migliori professionisti, accompagnandoli nei loro gesti quotidiani.

Il dialogo, l'ascolto e la collaborazione con loro fanno parte del nostro DNA aziendale. Ci offrono la loro esperienza per testare i nostri prodotti, valutandone praticità e resistenza, al fine di trovare le migliori soluzioni.

We love describing our products through the expert hands of the best professionals, supporting them in their daily gestures.

Communication, listening and cooperation with professionals are part of our corporate DNA. They offer us their experience to test our products, evaluating their practicality and resistance, in order to find the best solutions.



**I NOSTRI PARTNER
SUL TERRITORIO**
THE PARTNERS
IN OUR AREA



IDENTITÀ GOLOSE

Nasce nel gennaio del 2004 dall'idea di Paolo Marchi di dar vita al primo congresso italiano di cucina e pasticceria d'autore. PIAZZA ha creduto da subito a questo progetto e da allora ne è sponsor tecnico, fornendo le attrezzature alle cucine durante le varie fasi delle manifestazioni.

Born in January 2004 from a Paolo Marchi's idea: set up the first Italian congress of signature cuisine and pastry. Right from the beginning, PIAZZA trusted this project and since then it has been a technical sponsor, providing kitchen equipments and accessories during events and demonstrations.



AIBES

L'Associazione Italiana Barmen e Sostenitori riunisce ogni anno i professionisti e le aziende che operano nel mondo del bar, guidati dalla volontà di sostenere e tutelare la professione del barman. La storia di AIBES si intreccia con quella di PIAZZA poiché entrambi accomunati dall'impegno nel sostenere il mondo del bar in tutte le sue sfaccettature: mixology, flair e caffetteria.

A.I.B.E.S., Italian Barmen and Sponsor Association, gathers professionals and companies both working in bartending world and yearning to support and protect the profession of barman. A.I.B.E.S. and PIAZZA both share a commitment to support all sides of the world of bartending: mixology, flair and coffee bar.



AMBASCIATORI DEL GUSTO

L'Associazione Italiana Ambasciatori del Gusto nasce nel 2016 con l'idea di valorizzare e promuovere l'eccellenza dell'accoglienza e della ristorazione italiana. Si compone non solo di cuochi, ristoratori, pizzaioli, giornalisti, ricercatori e scrittori ma anche di una cerchia di partner che operano nel settore del Made in Italy. Tutti questi attori si uniscono per farsi ambasciatori, nel mondo, del concetto italiano di gusto e alta qualità.

The Italian Association Ambasciatori del Gusto was founded in 2016 with the aim of enhancing and promoting the excellence of Italian hospitality and dining. It comprises not only chefs, restaurateurs, pizza makers, journalists, researchers, and writers, but also a circle of partners operating in the Made in Italy sector. All these players come together to act as ambassadors, around the world, of the Italian concept of taste and high quality.





ACCESSORI

ACCESSORIES

| | |
|---|----|
| MOLLE TONGS | 12 |
| PINZE SCISSOR SERVERS | 18 |
| PORZIONATORI GELATO ICE-CREAM SCOOPS | 20 |
| SPATOLE E BACINELLE GELATO ICE-CREAM SERVERS AND CONTAINERS | 22 |
| TAPPI VERSATORI POURERS | 24 |
| COLINI MESH STRAINERS | 30 |



Molla per servire

| Serving tongs | Cod. | L cm | Box |
|---------------|---------------|------|-----|
| | 010000 | 23 | 12 |



Molla per ghiaccio

| Ice cube tongs | Cod. | L cm | Box |
|----------------|---------------|------|-----|
| | 010400 | 18 | 12 |



Molla per servire

| Serving tongs | Cod. | L cm | Box |
|---------------|---------------|------|-----|
| | 010100 | 23 | 12 |



Molla per zucchero

| Sugar tongs | Cod. | L cm | Box |
|-------------|---------------|------|-----|
| | 010500 | 12,5 | 12 |



Molla per pane a conchiglia

| Bread tongs | Cod. | L cm | Box |
|-------------|---------------|------|-----|
| | 010200 | 26 | 12 |
| | 010223 | 23 | 12 |



Molla per dolci

| Pastry tongs | Cod. | L cm | Box |
|--------------|---------------|------|-----|
| | 010600 | 18 | 12 |



Molla per spaghetti

| Spaghetti tongs | Cod. | L cm | Box |
|-----------------|---------------|------|-----|
| | 010300 | 23,5 | 12 |
| | 010326 | 26 | 12 |



GUARDA COME NASCONO
LOOK HOW THEY ARE BORN



MOLLE PIAZZA: SEMPLICEMENTE INDISPENSABILI
PIAZZA TONGS: SIMPLY INDISPENSABLE

Le molle PIAZZA sono da sempre punto di riferimento per il mercato, sia per il design che per l'effettiva superiorità di un prodotto immancabile nella collezione di ogni professionista.

I dettagli risaltano l'unicità di ogni singola molla: la curvatura di alcune applicazioni, quale la molla spaghetti, come invito per raccogliere meglio gli alimenti, il molleggio che conferisce sempre la stessa maneggevolezza anche dopo un numero infinito di pressioni, grazie ad un accorgimento produttivo esclusivo e ancora oggi riservato, come le formule che resistono da anni a ogni tentativo di imitazione. Proprio questa sicurezza permette solo a PIAZZA di garantire l'inalterabilità delle proprie molle.

PIAZZA's tongs have always been the collection used as reference point for the market, both for design and for the effective superiority of a product that is a must for every professional's collection.

Lastly, the details highlight the uniqueness of each individual pair: the curvature of certain applications, such as the spaghetti tongs, which is like an invitation to gather up the food in the best way; or the spring which always gives the same manoeuvrability even after an infinite number of pressing, this thanks to an exclusive production device which is still secret today, as are the formulas which for years have resisted all attempts of imitation.

Precisely this certainty permits PIAZZA alone to guarantee the inalterability of its tongs.

LE "MOLLUNGHE"
PIAZZA 'MOLLUNGHE'

Quattro pezzi speciali che grazie al loro esclusivo e caratteristico design, più lungo delle normali molle, daranno un'impronta raffinata al vostro buffet.

Four perfect items that, thanks to their unique and distinctive design, give an impression of great elegance for your buffet table.



Mollunga per spaghetti

Design by Michele Capuani

| | | | |
|-----------------------------------|---------------|------|-----|
| Buffet spaghetti tongs 'Mollunga' | Cod. | L cm | Box |
| | 010700 | 30 | 12 |



Mollunga per servire

Design by Michele Capuani

| | | | |
|-------------------------|---------------|------|-----|
| Buffet tongs 'Mollunga' | Cod. | L cm | Box |
| | 010800 | 30 | 12 |



Mollunga per carne e verdure

Design by Michele Capuani

| | | | |
|------------------------------|---------------|------|-----|
| Buffet meat tongs 'Mollunga' | Cod. | L cm | Box |
| | 010900 | 30 | 12 |



Mollunga per toast e dolci

Design by Michele Capuani

| | | | |
|-------------------------------|---------------|------|-----|
| Buffet toast tongs 'Mollunga' | Cod. | L cm | Box |
| | 011000 | 30 | 12 |





Molla per ghiaccio

Ice cube tongs

| Cod. | L cm | Box |
|---------------|------|-----|
| 011100 | 20 | 12 |



Molla per spaghetti

Spaghetti tongs

| Cod. | L cm | Box |
|---------------|------|-----|
| 011800 | 19,5 | 12 |



Molla per zucchero

Sugar tongs

| Cod. | L cm | Box |
|---------------|------|-----|
| 011200 | 11 | 12 |



Molla per dolci

Pastry tongs

| Cod. | L cm | Box |
|---------------|------|-----|
| 011900 | 16,5 | 12 |



Molla per zucchero

Sugar tongs

| Cod. | L cm | Box |
|---------------|------|-----|
| 011300 | 14 | 12 |



Molla per asparagi

Asparagus tongs

| Cod. | L cm | Box |
|---------------|------|-----|
| 012000 | 19 | 12 |



Molla per asparagi individuale

Individual asparagus tongs

| Cod. | L cm | Box |
|---------------|------|-----|
| 011400 | 13 | 12 |



Molla per insalata

Salad tongs

| Cod. | L cm | Box |
|---------------|------|-----|
| 012100 | 19,5 | 12 |



Molla per ghiaccio

Ice cube tongs

| Cod. | L cm | Box |
|---------------|------|-----|
| 011500 | 16 | 12 |



Molla per vegetali

Vegetables tongs

| Cod. | L cm | Box |
|---------------|------|-----|
| 012200 | 19,5 | 12 |



Molla per lumache

Snail tongs

| Cod. | L cm | Box |
|---------------|------|-----|
| 011600 | 16 | 12 |



Molla per servire

Serving tongs

| Cod. | L cm | Box |
|---------------|------|-----|
| 012300 | 19,5 | 12 |



Molla per spaghetti

Spaghetti tongs

| | | |
|---------------|------|-----|
| Cod. | L cm | Box |
| 012400 | 20,5 | 12 |



Pinza per servire

Serving tongs

| | | |
|---------------|------|-----|
| Cod. | L cm | Box |
| 012800 | 24 | 12 |



Molla per toast e dolci

Toast tongs

| | | |
|---------------|------|-----|
| Cod. | L cm | Box |
| 012500 | 21 | 12 |



Molla per affettati

Sliced ham tongs

| | |
|---------------|-----|
| Cod. | Box |
| 012900 | 12 |



Molla per asparagi

Asparagus tongs

| | | |
|---------------|------|-----|
| Cod. | L cm | Box |
| 012600 | 20 | 12 |



Molla collezione "Allan Bay"

'Allan Bay' Collection tongs

| | |
|---------------|-----|
| Cod. | Box |
| 013000 | 6 |



NEW

Molla per carne e vegetali

Serving tongs

| | | |
|---------------|------|-----|
| Cod. | L cm | Box |
| 012700 | 21 | 12 |



Molla per barbecue

Barbecue tongs

| | |
|---------------|------|
| Cod. | L cm |
| 014000 | 50 |





Molla di precisione per cucina

Design by Michele Capuani

| Precision kitchen tongs | Cod. | L cm | Box |
|-------------------------|---------------|------|-----|
| | 014500 | 30 | 12 |
| | 014515 | 15 | 12 |
| | 014523 | 23,5 | 12 |
| | 014540 | 40 | 12 |



Molla universale per cucina

Design by Michele Capuani

| All-in-one kitchen tongs | Cod. | L cm | Box |
|--------------------------|---------------|------|-----|
| | 015000 | 30 | 12 |
| | 015012 | 12 | 12 |
| | 015018 | 18 | 12 |
| | 015023 | 23,5 | 12 |



Molla di precisione 40° per cucina

Design by Michele Capuani

| 40° precision kitchen tongs | Cod. | L cm | Box |
|-----------------------------|---------------|------|-----|
| | 014600 | 30 | 12 |
| | 014615 | 15 | 12 |
| | 014623 | 23,5 | 12 |



Molla fonda per cucina

Design by Michele Capuani

| Curved kitchen tongs | Cod. | L cm | Box |
|----------------------|---------------|------|-----|
| | 015500 | 30 | 12 |
| | 015518 | 18 | 12 |
| | 015523 | 23,5 | 12 |



LE MOLLE TEST E KAIMAN: PENSATE DA LUCIANO TONA E CONCRETIZZATE DAL DESIGN DI MICHELE CAPUANI

THE TEST AND KAIMAN TONGS: AN ORIGINAL IDEA BY LUCIANO TONA, DESIGNED BY MICHELE CAPUANI



Molla Test

Design by Michele Capuani

| Test tongs | Cod. | L cm | Box |
|------------|---------------|------|-----|
| | 014100 | 13,5 | 12 |



Molla Kaiman

Design by Michele Capuani

| Kaiman tongs | Cod. | L cm | Box |
|--------------|---------------|------|-----|
| | 014200 | 18 | 12 |



Un oggetto indispensabile per i professionisti della ristorazione grazie alla capacità di racchiudere in 13,5 cm molteplici funzioni.

- CUCCHIAINO PER L'ASSAGGIO DELLE PREPARAZIONI
- PINZA DALLA PRECISIONE CHIRURGICA
- MISURINO GRADUATO (0,5 CM)

A new tool measuring just 13.5 cm that's bound to become indispensable for all catering professionals as it offers so many different functions.

- SPOON FOR TASTING FOOD
- TONGS FOR ASSEMBLING PREPARATIONS WITH SURGICAL PRECISION
- SCALED MEASURE (0.5 CM)



La Molla Kaiman affianca la Test, ampliando la vasta gamma delle molle cucina PIAZZA.

Progettata per la lavorazione del pesce.

- BECCUCCI DELISCATRICI DI PRECISIONE
- TACCHE POSTERIORI PER RIFINIRE LA SQUAMATURA
- SPECIALE ZIGRINATURA ANTISCIVOLO PER UNA PRESA SEMPRE SICURA

The Kaiman tongs is added to the popular Test tongs, extending the wide range of PIAZZA kitchen tongs. Specifically designed for fish.

- PRECISION FISH BONE REMOVERS
- REAR NOTCHES FOR PERFECT FISH SCALING
- NON-SLIP RIDGES FOR A SECURE GRIP





Molla universale nylon

Design by Michele Capuani

| Nylon all-in-one tongs | Cod. | L cm | Box |
|------------------------|---------------|------|-----|
| | 018600 | 23 | 12 |
| | 018700 | 30 | 12 |



Molla di precisione nylon & fiberglass

Design by Michele Capuani

| Nylon & fiberglass precision tongs | Cod. | L cm | Box |
|------------------------------------|-----------------|------|-----|
| | 01833000 | 30 | 12 |



SBLOCCO FACILE
EASY RELEASE



MOLLA A SCOMPARSA
DROP SPRING



Molla universale nylon & fiberglass

Design by Michele Capuani

| Nylon & fiberglass all-in-one tongs | Cod. | L cm | Box |
|-------------------------------------|-----------------|------|-----|
| | 01822302 | 23 | 12 |
| | 01823002 | 30 | 12 |
| | 01824002 | 40 | |



Molla toast nylon

Design by Michele Capuani

| Nylon toast tongs | Cod. | L cm | Box |
|-------------------|-----------------|------|-----|
| | 01813000 | 30 | 12 |



THE SPECIAL MIX
NYLON & FIBERGLASS

Le nuove molle **PIAZZA** nate interamente in Italia. Lo speciale polimero con cui vengono prodotte: una combinazione di nylon e fibra di vetro, garantisce praticità d'uso e durata nel tempo.

- RESISTENTI AL CALORE FINO A 220°C
- L'ASSENZA DI SALDATURE GARANTISCE MASSIMA IGIENE
- LAVABILI IN LAVASTOVIGLIE

PIAZZA new tongs are fully made in Italy. They are made of a special polymer, a combination of nylon and fiberglass, that gives great guarantee of lasting in time and ease of use.

- HEAT RESISTANT UP TO 220°C (430°F)
- THE ABSENCE OF WELDINGS GUARANTEES MAXIMUM HYGIENE
- DISHWASHER SAFE





Pinza per dolci forgiata

| | | |
|-----------------------|---------------|------|
| Pastry scissor server | Cod. | L cm |
| | 020000 | 18,5 |



Pinza per dolci forgiata

| | | |
|--|----------------|------|
| Pastry scissor server | Cod. | L cm |
| | 020300 | 21 |
|  Cod. 0203001 | 0203001 | 21 |



Pinza per dolci forgiata

| | | |
|-----------------------|---------------|------|
| Pastry scissor server | Cod. | L cm |
| | 020100 | 20 |



Pinza per torta forgiata

| | | |
|--------------------|---------------|------|
| Pie scissor server | Cod. | L cm |
| | 020400 | 25 |



Pinza per dolci forgiata

| | | |
|--|----------------|------|
| Pastry scissor server | Cod. | L cm |
| | 020200 | 20 |
|  Cod. 0202001 | 0202001 | 20 |



Pinza per antipasti forgiata

| | | |
|------------------------------|---------------|------|
| Hors-d'ouvres scissor server | Cod. | L cm |
| | 020500 | 19 |



NATE PER SFIDARE IL TEMPO
BORN TO BE TIMELESS

Le pinze sono uno degli articoli storici della produzione Piazza. Alcune di loro sono diventate dei "classici" tanto da essere presenti in catalogo sin dai primi anni '60 con lo stesso design di quelle odierne, a testimonianza di un'attenzione particolare nei confronti della funzionalità dei nostri prodotti, una caratteristica che ci contraddistingue da sempre. Ancora oggi, come allora, vengono interamente prodotte in Italia, ponendo la massima cura nella loro realizzazione e nel loro assemblaggio in modo da renderle pressoché indistruttibili. La disponibilità infine di pezzi particolari, quali le pinze "Mignon", rende la gamma Piazza una delle più complete sul mercato.



Pinza per antipasti forgiata

Hors-d'ouvres scissor server

Cod. **020600**

L cm 19



Pinza per toast forgiata

Toast scissor server

Cod. **020900**

L cm 19



Pinza per dolci "Mignon" forgiata

Midget scissor server 'Mignon'

Cod. **020700**

L cm 15



Pinza per insalata forgiata

Salad scissor server

Cod. **021000**

L cm 24



Pinza per dolci "Mignon" forgiata

Midget scissor server 'Mignon'

Cod. **020800**

L cm 15



Pinza per forno

Hot plate holder

Cod. **021100**

L cm 18,5



Scissor servers are one of Piazza's classic products. Indeed, some of these have appeared in our catalogue since the early 1960s, with the same design today. This proves just how valuable is the great attention we pay to the functionality of our products, a characteristic that has always distinguished us. Today, as in the past, these products are made entirely in Italy. We pay the utmost attention to their production and assembly to make them virtually indestructible. Finally, the availability of specific items, such as the "Mignon" scissor servers, means that the Piazza range is one of the most comprehensive on the market today.

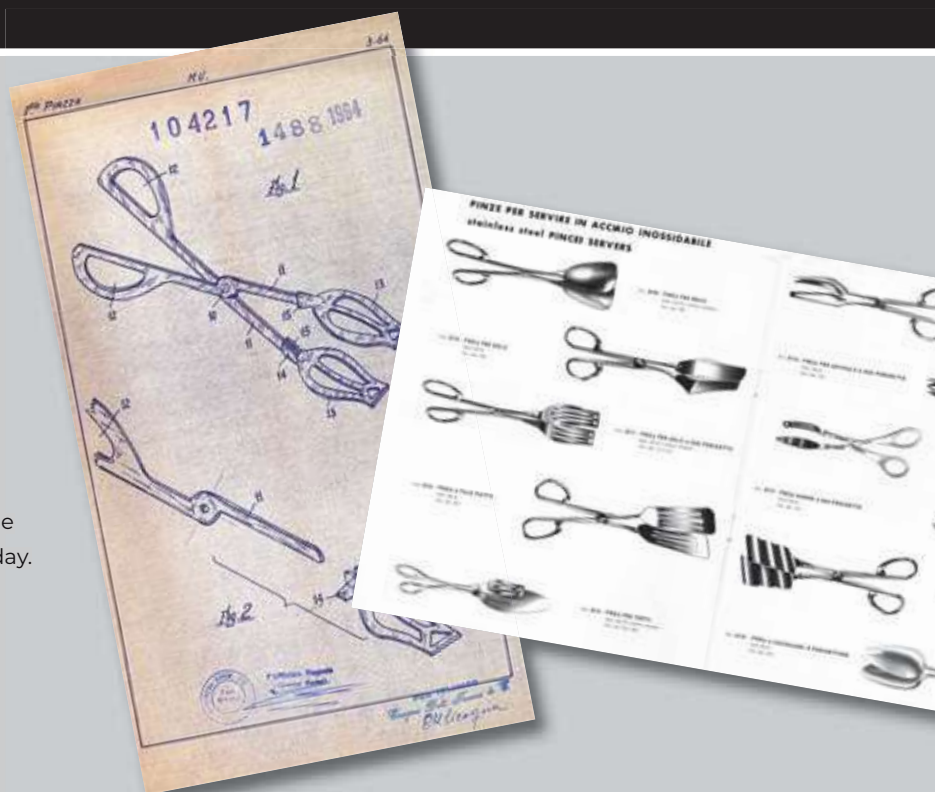

L'ABBIAMO INVENTATO NOI!
WE INVENTED IT!



I porzionatori costituiscono, nell'assortimento PIAZZA, un'azienda nell'azienda. Il fattore determinante è l'idea, infatti, il brevetto originale di questo prodotto appartiene a PIAZZA e risale agli anni '60.

Da allora è "Il Porzionatore", che, rinnovato costantemente, rappresenta oggi il riferimento qualitativo del settore, con soluzioni tecniche impareggiabili, quali

- SALDATURE ED ACCOPPIAMENTI AL LIMITE DELL'IMPOSSIBILE
- UN DISEGNO ERGONOMICO PERFETTO
- UN MECCANISMO INDISTRUTTIBILE CHE SOPPORTA STRESS DA UTILIZZO PRESSOCHÉ INFINITI
- ASSORTIMENTO VASTISSIMO (13 DIVERSE CAPACITÀ)

In the PIAZZA assortment, ice cream scoops constitute a company within a company. The determining factor is the idea. In fact the original patent for this product belongs to PIAZZA and dates back to the 60's.

Since then the 'Porzionatore', constantly renewed, represents the sector qualitative reference today, with unparalleled technical solutions such as

- WELDS AND COUPLINGS TO THE LIMITS OF THE HIGH IMPOSSIBLE
- PERFECT ERGONOMIC DESIGN
- AN INDESTRUCTIBLE MECHANISM WHICH CAN TOLERATE ALMOST INFINITE USER STRESS
- WIDE ASSORTMENT (13 DIFFERENT CAPACITIES).

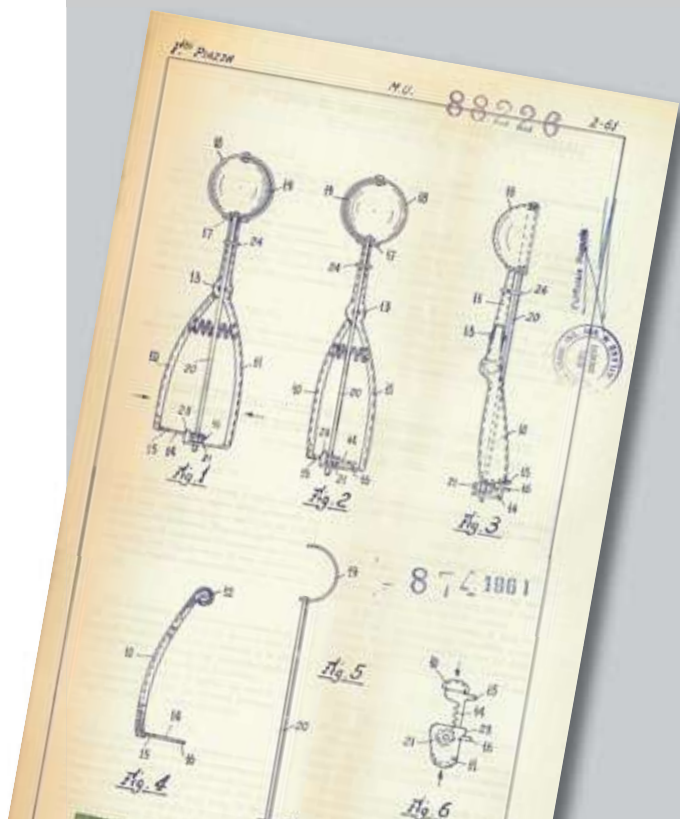

Porzionatore neoclassico

| Ice-cream scoop | Cod. | Ø cm | Cap. | Box |
|-----------------|---------------|------|----------|-----|
| | 030008 | 7,6 | 1/8 Lt | 4 |
| | 030010 | 7,3 | 1/10 Lt | 4 |
| | 030012 | 6,8 | 1/12 Lt | 4 |
| | 030016 | 6,1 | 1/16 Lt | 4 |
| | 030020 | 5,8 | 1/20 Lt | 6 |
| | 030024 | 5,3 | 1/24 Lt | 6 |
| | 030030 | 5 | 1/30 Lt | 6 |
| | 030036 | 4,7 | 1/36 Lt | 6 |
| | 030040 | 4,5 | 1/40 Lt | 6 |
| | 030050 | 4,1 | 1/50 Lt | 6 |
| | 030060 | 3,8 | 1/60 Lt | 6 |
| | 030070 | 3,5 | 1/70 Lt | 6 |
| | 030099 | 3,1 | 1/100 Lt | 6 |



CARATTERISTICHE TECNICHE

- **Interamente in acciaio inox 18/10**
- **Composti da 12 particolari perfettamente assemblati con saldature a proiezione ad alta tecnologia**
- **Adatti al lavaggio in lavastoviglie**
- **Elettrolucidati con metodi alimentari nel rispetto delle norme ambientali**
- **Creomaglieria con spessore di 2 mm per offrire una maggiore scorrevolezza**
- **Presenza di una bussolina di tenuta per impedire l'uscita dell'astina**
- **Scorrimento completo dell'astina sulla coppa per creare cerchi perfetti**
- **Testati per oltre un milione di palline**

AVVERTENZE E CONSIGLI D'USO

- **Per garantire un rendimento ottimale del porzionatore il gelato non dovrebbe avere una temperatura inferiore ai -15°C**
- **Si raccomanda di tenere il porzionatore sotto acqua corrente tiepida, ciò contribuisce a impedire la formazione di batteri e ne aumenta la scorrevolezza durante l'uso**

TECHNICAL DATA

- Made from 100% 18/10 st. steel
- 12 perfectly assembled components with hi-tech projection welding
- Dishwasher suitable
- Electropolished with feed methods compliant with environmental regulations
- 2 mm-thick rack for better smoothness
- A bush to prevent the rod from coming out
- Full movement of the rod within the cup to create perfect circles
- Tested by producing more than a million balls of ice-cream

WARNING AND HINTS

- To guarantee top efficiency of the ice-cream scoop, the ice-cream shouldn't be colder than -15°C
- We recommend placing the scoop under warm running water before use to avoid the formation of bacteria and to allow it to slide better during use



Porzionatore ovale

| Oval ice-cream scoop | Cod. | L cm | Cap. | Box |
|----------------------|---------------|---------|---------|-----|
| | 030130 | 4,5 x 6 | 1/30 Lt | 6 |



PORZIONATORE

ICE-CREAM SCOOP

LIGHT&STRONG



Porzionatore bianco con astina colorata

Ice-cream scoop, white with coloured steel bar

Design by Michele Capuani

| Cod. | Ø cm | Cap. | Col. | Box |
|----------|------|---------|------|-----|
| 03522401 | 5,3 | 1/24 Lt | ● | 6 |
| 03522402 | 5,3 | 1/24 Lt | ○ | 6 |
| 03522403 | 5,3 | 1/24 Lt | ● | 6 |
| 03522404 | 5,3 | 1/24 Lt | ● | 6 |
| 03522406 | 5,3 | 1/24 Lt | ● | 6 |
| 03522407 | 5,3 | 1/24 Lt | ● | 6 |
| 03523001 | 5 | 1/30 Lt | ● | 6 |
| 03523002 | 5 | 1/30 Lt | ○ | 6 |
| 03523003 | 5 | 1/30 Lt | ● | 6 |
| 03523004 | 5 | 1/30 Lt | ● | 6 |
| 03523006 | 5 | 1/30 Lt | ● | 6 |
| 03523007 | 5 | 1/30 Lt | ● | 6 |
| 03523601 | 4,7 | 1/36 Lt | ● | 6 |
| 03523602 | 4,7 | 1/36 Lt | ○ | 6 |
| 03523603 | 4,7 | 1/36 Lt | ● | 6 |
| 03523604 | 4,7 | 1/36 Lt | ● | 6 |
| 03523606 | 4,7 | 1/36 Lt | ● | 6 |
| 03523607 | 4,7 | 1/36 Lt | ● | 6 |
| 03524001 | 4,5 | 1/40 Lt | ● | 6 |
| 03524002 | 4,5 | 1/40 Lt | ○ | 6 |
| 03524003 | 4,5 | 1/40 Lt | ● | 6 |
| 03524004 | 4,5 | 1/40 Lt | ● | 6 |
| 03524006 | 4,5 | 1/40 Lt | ● | 6 |
| 03524007 | 4,5 | 1/40 Lt | ● | 6 |



Il porzionatore Light&Strong nasce dalla ricerca e dallo sviluppo del nostro ufficio tecnico e trova forme e colori freschi e accattivanti grazie alla matita di Michele Capuani. Un piccolo, grande concentrato di tecnologia e design, 100% Made in Italy, capace di offrirvi prestazioni ineguagliabili, in gelateria come in cucina.

The ice-cream scoop Light&Strong is the result of the research and development of our engineering office, while Michele Capuani designed fresh and attractive shapes and colors. A small, yet a great extract of technology and design, fully Made in Italy, which gives you unequalled performance in both an ice-cream parlor and at home.

THE SPECIAL MIX

NYLON & FIBERGLASS

MATERIALE

L'INNOVATIVA COMPOSIZIONE DI NYLON E FIBERGLASS CONIUGA UN'ELEVATA RIGIDITÀ E UNA GRANDE RESISTENZA MECCANICA AD UNA STRAORDINARIA LEGGEREZZA. HA UN RANGE TERMICO DA -30°C A +170°C, È TRANQUILLAMENTE LAVABILE IN LAVASTOVIGLIE ED È PIENAMENTE A NORMA CON LE LEGGI CEE E FDA USA.

CREMAGLIERA

IL GIOCO DEL MECCANISMO, CALIBRATO ALLA PERFEZIONE, CONSENTE LA MASSIMA SCORREVOLEZZA CON IL MINIMO SFORZO DI PRESSIONE, RIDUCENDO QUINDI FATICA E STANCHEZZA.

FASCETTA

REALIZZATA IN ACCIAIO INOX OFFRE UN TAGLIO OTTIMALE DEL GELATO E, ASSIEME ALLA COPPA LUCIDATA, PRODUCE SEMPRE PALLINE PERFETTE.

ASTINA E MOLLA

ANCH'ESSE IN ACCIAIO INOX POSSIEDONO UN'EFFICACIA DI FUNZIONAMENTO SENZA PARI ASSOCIATA A MASSIMA ROBUSTEZZA, INALTERABILITÀ DI FUNZIONAMENTO E DURATA NEL TEMPO.

PERNO CENTRALE

IL CONTROLLO SCRUPOLOSO DELLE TOLLERANZE IN FASE DI STAMPAGGIO PRIMA ED IN ASSEMBLAGGIO POI, ASSIEME AL DESIGN COMPATTO, GARANTISCONO LA MASSIMA IGIENICITÀ DEL PORZIONATORE PER L'ASSENZA DI PUNTI OVE POSSA DEPOSITARSI LO SPORCO.

IMPUGNATURA

PERFETTAMENTE ERGONOMICA E, GRAZIE ALLA SPECIALE SUPERFICIE SATINATA, È TOTALMENTE ANTISCIVOLO PER UNA PRESA SEMPRE SALDA E SICURA.

MATERIAL

THE INNOVATIVE COMPOSITION OF NYLON AND FIBERGLASS MATCHES STIFFNESS, GREAT MECHANICAL STRENGTH AND EXTRAORDINARY LIGHTNESS. IT STANDS TEMPERATURES FROM -30°C TO +170°C, IS DISHWASHER SAFE AND FULLY COMPLIES WITH EEC AND FDA STANDARDS.

RACK

THE PERFECTLY ADJUSTED MECHANISM PROVIDES EXCELLENT SLIDING WITH MINIMUM PRESSURE EFFORT, THEN CUTTING DOWN FATIGUE AND TIREDNESS.

STRIP

MADE OF STAINLESS STEEL, IT PROVIDES THE BEST CUT OF ICE-CREAM AND, TOGETHER WITH THE POLISHED CUP, ALWAYS RESULTS IN PERFECT SHAPE SCOOPS.

ROD AND SPRING

THEY ARE ALSO MADE OF STAINLESS STEEL AND THEIR OPERATION IS UNPARALLELED; THEY ARE VERY STRONG, HAVE A LONG LIFE AND THEIR OPERATION UNDERGOES NO CHANGE.

CENTRAL HUB

CAREFUL CHECK ON ALLOWANCES, FIRST DURING THE MOLDING AND THEN THE ASSEMBLY STAGE, GUARANTEES, TOGETHER WITH COMPACT DESIGN, TOP HYGIENE OF THE SCOOP BECAUSE THERE ARE NO AREAS WHERE RESIDUES OF DIRT CAN SETTLE.

HANDLE

PERFECTLY ERGONOMIC AND, WITH ITS SPECIAL MATTE SURFACE, IT IS FULLY ANTI-SLIP FOR A STRONG AND SAFE GRIP AT ALL TIMES.





Spatola per gelato

| Ice-cream server | Cod. | L cm | Box |
|---|---------------|------|-----|
|  | 040020 | 20 | 5 |
| | 040025 | 25 | 5 |



Spatola per gelato manico tubolare chiuso

| Ice-cream server | Cod. | L cm |
|---|---------------|------|
|  | 040125 | 25 |



Spatola per gelato manico colorato

| Ice-cream server | Cod. | L cm | Col. |
|---|---------------|------|------|
|  | 040500 | 25 | ○ |
| | 040501 | 25 | ● |
| | 040502 | 25 | ● |
| | 040503 | 25 | ● |



Spatola per gelato manico colorato trasparente 25 cm

| Ice-cream server 25 cm | Cod. | L cm | Col. |
|---|---------------|------|------|
|  | 040507 | 25 | ○ |
| | 040511 | 25 | ● |
| | 040512 | 25 | ● |
| | 040513 | 25 | ● |
| | 040517 | 25 | ● |
| | 040518 | 25 | ● |



Spatola per gelato manico colorato

| Ice-cream server | Cod. | L cm | Col. | Box |
|---|---------------|------|------|-----|
|  | 040600 | 30 | ○ | 5 |
| | 040601 | 30 | ● | 5 |
| | 040602 | 30 | ● | 5 |
| | 040603 | 30 | ● | 5 |





Bacinella gelato 265 x 160

| Ice-cream container | Cod. | L x W cm | H cm | cl |
|---------------------|---------------|-----------|------|-----|
| | 045215 | 26,5 x 16 | 15 | 400 |
| | 045217 | 26,5 x 16 | 17 | 470 |



Bacinella gelato 330 x 165

| Ice-cream container | Cod. | L x W cm | H cm |
|---------------------|---------------|-----------|------|
| | 045312 | 33 x 16,5 | 12 |
| | 045315 | 33 x 16,5 | 15 |
| | 045318 | 33 x 16,5 | 18 |



Bacinella gelato 360 x 165

| Ice-cream container | Cod. | L x W cm | H cm | cl |
|---------------------|---------------|-----------|------|-----|
| | 045408 | 36 x 16,5 | 8 | 350 |
| | 045412 | 36 x 16,5 | 12 | 500 |
| | 045415 | 36 x 16,5 | 15 | 650 |
| | 045418 | 36 x 16,5 | 18 | 770 |



Bacinella gelato 360 x 250

| Ice-cream container | Cod. | L x W cm | H cm | cl |
|---------------------|---------------|----------|------|-----|
| | 045507 | 36 x 25 | 7 | 470 |
| | 045512 | 36 x 25 | 12 | 800 |



Coperchio in plexiglass

| Plexiglass lid | Cod. | L x W cm |
|----------------|---------------|-----------|
| | 045726 | 26,5 x 16 |
| | 045733 | 33 x 16,5 |



**Carapina stampata
200 x 250**

| Cylindrical ice-cream container | Cod. | Ø cm | H cm |
|---------------------------------|---------------|------|------|
| | 045900 | 20 | 25 |





Tappo versatore con capsula di chiusura

Pouring cork with closure cap

Cod. **0500004**

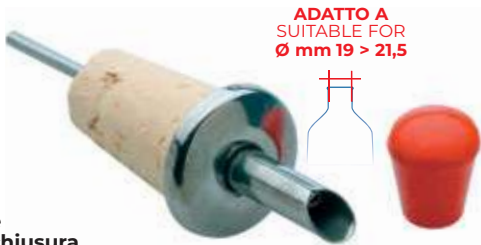

ADATTO A
SUITABLE FOR
Ø mm 19 > 21,5



Tappo versatore curvo

Curved pouring cork

Cod. **0503004**



ADATTO A
SUITABLE FOR
Ø mm 19 > 21



Tappo versatore dritto

Straight pouring cork

Cod. **0501004**



ADATTO A
SUITABLE FOR
Ø mm 19 > 21



Tappo versatore curvo con silicone

Curved pouring cork with silicone

Cod. **0503014**



ADATTO A
SUITABLE FOR
Ø mm 17,5 > 18



Tappo versatore dritto con silicone

Straight pouring cork with silicone

Cod. **0501014**



ADATTO A
SUITABLE FOR
Ø mm 17,5 > 18



Tappo versatore ricuperatore

Drop stop pouring cork

Cod. **0505004**

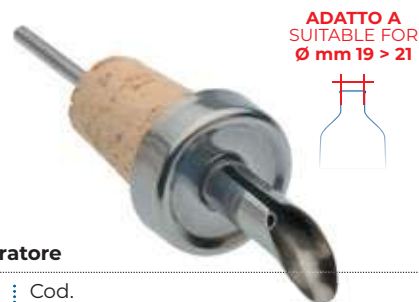

ADATTO A
SUITABLE FOR
Ø mm 19 > 21



Tappo versatore dritto con capsula di chiusura

Straight pouring cork with closure cap

Cod. **0502004**

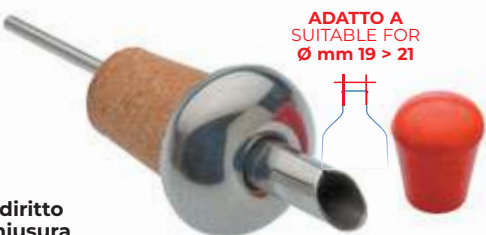

ADATTO A
SUITABLE FOR
Ø mm 19 > 21



Tappo versatore ricuperatore con silicone

Drop stop pouring cork with silicone

Cod. **0505014**



ADATTO A
SUITABLE FOR
Ø mm 17,5 > 18



Confezione 4 tappi versatori (2 pz. 050000 + 2 pz. 050300)

Pack 4 pouring corks (2 pcs. 050000 + 2 pcs. 050300) Cod. **050601**





I TAPPI VERSATORI PIAZZA: SINTESI PERFETTA DI TRADIZIONE E INNOVAZIONE

PIAZZA POURERS: A PERFECT SYNTHESIS BETWEEN TRADITION AND INNOVATION

I tappi versatori sono parte della storia di PIAZZA.

L'applicazione di materiali e tecnologie innovative all'oggetto che per primo ha dato avvio alla produzione di utensili professionali in acciaio PIAZZA, è simbolo di costante ed approfondita ricerca di qualità e funzionalità.

Sintesi di acciaio e silicone il tappo versatore in Soflex esalta le caratteristiche positive di entrambi i materiali; all'ormai sperimentata praticità dei particolari in acciaio:

- BECCUCCIO SALVAGOCCIA
- CANNUCCIA PER L'ARIA
- ROBUSTO ED IGIENICO COPERCHIO

si aggiunge un rivestimento lamellare in soflex, che, per le intrinseche caratteristiche del materiale e per l'appositamente studiata conformazione a lamelle, garantisce un impiego perfetto,

- INSERIMENTO FACILE E RESISTENZA ALLA FUORIUSCITA
- CHIUSURA ERMETICA
- SCORRIMENTO AGEVOLATO DI OGNI TIPO DI LIQUIDO (OLIO, LIQUORE, VINO)
- NESSUN RISCHIO DI PERDITA, DI SCIVOLAMENTO DEL TAPPO, DI PERMANENZA DI ODORE SULLA PARTE IN SOFLEX

Pourers are part of PIAZZA's industrial history.

The application of innovative materials and technologies to the object which first triggered production of PIAZZA professional utensils in steel, is symbol of the constant, in-depth search for quality and functionality.

A synthesis of steel and silicone, the pourers in silicone highlight the positive features of both materials: to the well tried practicality of the details in steel,

- DRIP-CATCHER SPOUT
- AIR INLET AND TOUGH
- HYGIENIC LID

is added a lamellar covering in silicone which, due to the intrinsic characteristics of the material and the specially designed lamella conformation, guarantees perfect use

- EASY INSERTION
- RESISTANCE TO LEAKS,
- HERMETIC CLOSURE WITH EASY FLOW OF ALL TYPES OF LIQUIDS (OIL, LIQUEUR, VINEGAR)
- NO RISK OF LEAKING, OF THE CORK SLIPPING OR OF ODOURS REMAINING ON THE PART IN SILICONE





ADATTO A
SUITABLE FOR
Ø mm 17,5 > 18

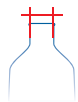

Design by Marco Valente

Tappo versatore con silicone Design-Pourer

Design-Pourer silicone gear

Cod. **050800**



ADATTO A
SUITABLE FOR
Ø mm 17,5 > 18



Design by Marco Valente

Tappo versatore con silicone Tech-Pourer

Tech-Pourer silicone gear

Cod. **0509004**



Tappo versatore con silicone Tech-Pourer

Tech-Pourer silicone gear

Cod. **0510004**



ADATTO A
SUITABLE FOR
Ø mm 17,5 > 18



Design by Marco Valente



Tappo versatore con silicone Tech-Pourer

Tech-Pourer silicone gear

Cod. **0511004**



ADATTO A
SUITABLE FOR
Ø mm 17,5 > 18



Design by Marco Valente



Tappo versatore con silicone Soft-Pourer

Pourer Soft-Pourer

Cod. **0512004**

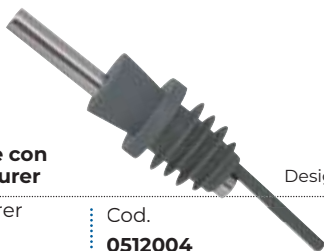

ADATTO A
SUITABLE FOR
Ø mm 17,5 > 18



Design by Marco Valente



Tappo versatore con silicone Soft-Pourer

Pourer Soft-Pourer

Cod. **0513004**



ADATTO A
SUITABLE FOR
Ø mm 17,5 > 18



Design by Marco Valente

051400
051500



051600

051601

Capsula, sughero e silicone per tappo versatore

Capsule cork and silicone for pouring cork

| Cod. | Per/For | Box |
|--------|---------|-----|
| 051400 | 050000 | 24 |
| 051500 | 050200 | 24 |
| 051600 | | 24 |
| 051601 | | 24 |



Silicone per tappi Pourers

Spare part for Pourers

| Cod. | Box |
|--------|-----|
| 051700 | 24 |



ADATTO A
SUITABLE FOR
Ø mm 17,5 > 18



Design by Marco Valente

Tappo versatore per vino con chiusura

Closable wine-pouring stopper

| Cod. | Box |
|--------|-----|
| 051800 | 18 |



Silicone per tappo vino (051800)

Spare part for pourer 051800

| Cod. | Box |
|--------|-----|
| 051900 | 24 |





ADATTO A
SUITABLE FOR
Ø mm 17,5 > 18



Tappo versatore dosatore in acciaio inox

Measuring stainless steel pourer
Cod. **05321012**



ADATTO A
SUITABLE FOR
Ø mm 17,5 > 18



Tappo versatore dosatore inox con chiusura

Measuring stainless steel pourer with lid
Cod. **05325012**



NEW

ADATTO A
SUITABLE FOR
Ø mm 17,5 > 18



Tappo versatore dosatore inox con cappuccio

Measuring stainless steel pourer with closure cap
Cod. **0532552**



Tappo versatore continuo

Design by Marco Valente

| Continuous pourer | Cod. | Col. | Box |
|-------------------|-----------------|------|-----|
| | 05350112 | | 4 |
| | 05350312 | | 4 |
| | 05350412 | | 4 |
| | 05350612 | | 4 |



BPour, tester per dosaggi

| BPour, pour check | Cod. | Ø cm | H cm |
|-------------------|---------------|------|------|
| | 053290 | 10,5 | 16,5 |



Tappo versatore metrico

| Metric pourer | Cod. | ml | Col. |
|---------------|----------------|----|------|
| | 0540153 | 15 | |
| | 0540203 | 20 | |
| | 0540253 | 25 | |
| | 0540303 | 30 | |
| | 0540353 | 35 | |
| | 0540403 | 40 | |
| | 0540503 | 50 | |





Cod. 0533002

Cod. 0533006



ADATTO A
SUITABLE FOR
Ø mm 18,5 > 21

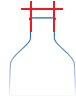

Tappo versatore SteadySpout 2.0

SteadySpout 2.0 pourer Cod.
0533002
Cod. 0533006 Cod. 0533006



STEADYSPOUT 2.0

THE EVOLUTION OF THE METAL POURER

Con SteadySpout avrai un versaggio sempre costante a 157BPM, l'unità di misura usata dai bartender per calibrare perfettamente la quantità di liquido nella preparazione dei cocktail.

INALTERABILE

La speciale plastica dotata di "memoria" torna alla forma originale con un passaggio in lavastoviglie.

ROBUSTO

Composto da 2 soli pezzi invece che 4. Più solido e più resistente all'usura.

Maggiore durata nel tempo rispetto ai diretti concorrenti.

PRECISO

Velocità d'uscita del liquido garantita dalla presa d'aria. Nessuna goccia sia all'inizio che alla fine del versaggio. Ideale per la tecnica del jumping.

UNIVERSALE

Disegno e materiale delle lamelle offrono massima presa e inserimento/disinserimento facile e veloce. Il doppio modulo di diametro lo rende adatto a bottiglie con collo da Ø18 a Ø21,5 mm.

BREVETTATO

Concepito, studiato e interamente progettato dall'ufficio tecnico di PIAZZA. 100% Made in Italy.

CARATTERISTICHE TECNICHE

- Cannuccia in acciaio inox 18/10 AISI 304 con lavorazione al laser
- Diametro, rastrematura e inclinazione della cannuccia perfettamente calibrati sia all'interno che all'esterno
- Lavabile in lavastoviglie

TECHNICAL SPECIFICATIONS

- Reed in AISI 304 18/10 laser processed stainless steel
- Perfectly calibrated diameter, tapering and inclination of the reed, both inside and outside
- Dishwasher friendly



SCOPRI COME
LO PRODUCIAMO
DISCOVER HOW
WE MANUFACTURE IT



With SteadySpout, the rate of pouring is always constant at 157BPM, the unit of measurement used by bartenders to perfectly calibrate the quantity of liquid in the preparation of cocktails.

NEVER CHANGES

Special plastic with "memory" returns to the original shape simply by putting it through the dishwasher.

STURDY

Composed of only 2 pieces rather than 4. Sturdier and more resistant to wear and tear. Longer duration compared to the other competitors.

ACCURATE

Pouring speed of the liquid guaranteed by the air intake. No spills either at the start or end of the pouring. Perfect for the jumping technique.

UNIVERSAL

Design and material of the reed valves offer maximum grip and an easy and fast plugging/unplugging. The double diameter module makes it suitable for bottles with necks of diameters from Ø18 to Ø21.5 mm.

PATENTED

Conceived, developed and entirely designed by PIAZZA's technical office. Entirely manufactured in Italy



FEEL THE BEAT
MIX THE DRINKS

**Colino a rete**

Mesh strainer

| Cod. | Ø cm |
|---------------|------|
| 060007 | 7 |
| 060009 | 9 |
| 060012 | 12 |
| 060014 | 14 |
| 060016 | 16 |
| 060018 | 18 |

**Colino a rete conico**

Conical mesh strainer

| Cod. | Ø cm |
|---------------|------|
| 060107 | 7 |
| 060109 | 9 |
| 060112 | 12 |
| 060114 | 14 |
| 060116 | 16 |
| 060118 | 18 |



Un vasto assortimento di articoli finalizzati a “scolare” gli alimenti, denota un’attenzione particolare al problema. La serie dei colini si distingue per la rete impiegata, la cui trama è fitta e resistente, nonché per la sua saldatura al corpo, rifinita e durevole.

A vast assortment of articles for straining foodstuffs, featuring special attention paid to the problem. The series of strainers is distinguished by the tough, close-mesh employed as well as by the lasting and well-finished welding to the body.



CUCINA

COOKWARE

| | |
|--|----|
| MOLLE CUCINA KITCHEN TONGS | 32 |
| COLLEZIONI PENTOLAME COOKWARE COLLECTIONS | 34 |
| ACCESSORI CUCINA KITCHEN ACCESSORIES | 47 |
| ARTICOLI TECNICI TECHNICAL ITEMS | 66 |
| COLTELLI KNIVES | 68 |
| CESTELLI RACKS | 76 |
| GASTRONORM IN ACCIAIO INOX GASTRONORM IN STAINLESS STEEL | 78 |
| GASTRONORM IN PLASTICA GASTRONORM IN PLASTIC | 82 |
| GASTRONORM IN POLIPROPILENE GASTRONORM IN POLYPROPYLENE | 83 |



Molla Test Design by Michele Capuani

| Test tongs | Cod. | L cm | Box |
|------------|---------------|------|-----|
| | 014100 | 13,5 | 12 |



Molla Kaiman Design by Michele Capuani

| Kaiman tongs | Cod. | L cm | Box |
|--------------|---------------|------|-----|
| | 014200 | 18 | 12 |



Molla di precisione per cucina Design by Michele Capuani

| Precision kitchen tongs | Cod. | L cm | Box |
|-------------------------|---------------|------|-----|
| | 014500 | 30 | 12 |
| | 014515 | 15 | 12 |
| | 014523 | 23,5 | 12 |
| | 014540 | 40 | 12 |



Molla di precisione 40° per cucina Design by Michele Capuani

| 40° precision kitchen tongs | Cod. | L cm | Box |
|-----------------------------|---------------|------|-----|
| | 014600 | 30 | 12 |
| | 014615 | 15 | 12 |
| | 014623 | 23,5 | 12 |



Molla universale per cucina Design by Michele Capuani

| All-in-one kitchen tongs | Cod. | L cm | Box |
|--------------------------|---------------|------|-----|
| | 015000 | 30 | 12 |
| | 015012 | 12 | 12 |
| | 015018 | 18 | 12 |
| | 015023 | 23,5 | 12 |



Molla fonda per cucina Design by Michele Capuani

| Curved kitchen tongs | Cod. | L cm | Box |
|----------------------|---------------|------|-----|
| | 015500 | 30 | 12 |
| | 015518 | 18 | 12 |
| | 015523 | 23,5 | 12 |



SBLOCCO FACILE
EASY RELEASE



MOLLA A SCOMPARSA
DROP SPRING



Molla universale nylon & fiberglass Design by Michele Capuani

| Nylon & fiberglass all-in-one tongs | Cod. | L cm | Box |
|-------------------------------------|-----------------|------|-----|
| | 01822302 | 23 | 12 |
| | 01823002 | 30 | 12 |
| | 01824002 | 40 | 12 |



Molla di precisione nylon & fiberglass Design by Michele Capuani

| Nylon & fiberglass precision tongs | Cod. | L cm | Box |
|------------------------------------|-----------------|------|-----|
| | 01833000 | 30 | 12 |



Molla universale nylon Design by Michele Capuani

| Nylon all-in-one tongs | Cod. | L cm | Box |
|------------------------|---------------|------|-----|
| | 018600 | 23 | 12 |
| | 018700 | 30 | 12 |



SCOPRI LA QUALITÀ
100% MADE IN ITALY
DISCOVER THE QUALITY
100% MADE IN ITALY

Per la cucina professionale "massima funzionalità" è una parola d'ordine.

Tutte le linee di pentolame PIAZZA sono frutto di una ricerca avanzata e costante e interpretano in modo esemplare questa importante esigenza.

La nuova collezione PROChef ne è l'esempio migliore, unendo perfettamente tradizione e innovazione.

Conserva un particolare classico, come la maniglia brevettata, con intatte tutte le caratteristiche che ne garantiscono una resistenza infinita e le migliori performance del mercato.

Il suo nuovo fondo termoconduttore, progettato per resistere ai lavaggi intensivi, è realizzato con un'anima in alluminio di maggiore spessore, racchiusa in un fondello di acciaio inox. I due materiali vengono fusi insieme grazie ad un'avanzata tecnologia di battitura.

L'alluminio più spesso, posizionato più vicino ai bordi della pentola, assicura una distribuzione uniforme e rapida del calore, riducendo i tempi di cottura e il dispendio di energia, migliorando così la resa dei piatti.

Il rivestimento in acciaio inox protegge il fondo dall'usura e dagli agenti esterni, preservando le prestazioni nel tempo e ottimizzando la diffusione del calore su tutti i sistemi di cottura.

- ALTI SPESSORI
- ROBUSTEZZA
- RESISTENZA ALL'USURA
- FINITURE DI PREGIO
- SALDATURE INDISTRUTTIBILI
- MANIGLIE CAVE ED ERGONOMICHE

- THICK
- TOUGH
- WEAR-RESISTANT
- FINE FINISH
- INDESTRUCTIBLE WELDING
- HOLLOW ERGONOMIC HANDLES



'Top functionality' is the keyword for professional cooking. All PIAZZA lines of pots and pans are the result of continuous state-of-the-art research and a perfect example of interpretation of this important requirement.

The new PROChef collection, which perfectly mixes tradition and innovation, is the best example of this concept.

Maintains the patented handle, a classical detail, with its all characteristics that have guaranteed and still guarantees endless strength and top performance on the market.



Its new heat-conducting base, designed to withstand intensive washing, is made of a thicker aluminum core, enclosed in a stainless steel base. The two materials are fused together thanks to advanced bonding technology. The thicker aluminum, positioned closer to the edges of the pot, ensures uniform and rapid heat distribution, reducing cooking times and energy waste, thus improving dishes' quality.

The stainless steel coating protects the base from wear and external agents, preserving performance over time and optimizing heat diffusion on all cooking hobs.

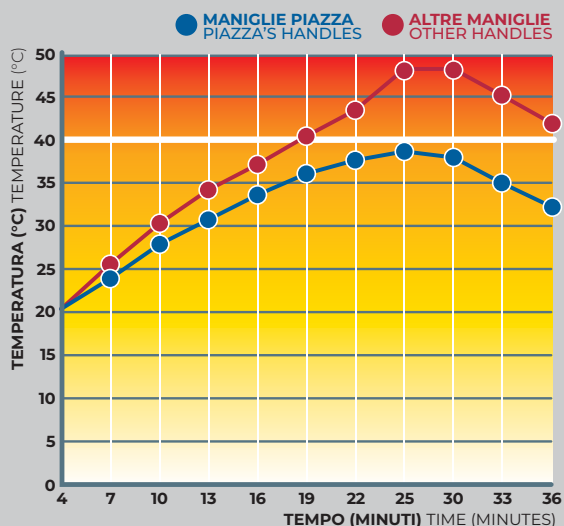

IL GRAFICO MOSTRA I VALORI DELLE TEMPERATURE RAGGIUNTI DALLE MANIGLIE DELLE PENTOLE DELLA SERIE "PROCHEF" PIAZZA CONFRONTATI CON QUELLI DELLE ALTRE MANIGLIE PRESENTI SUL MERCATO. COME SI PUÒ NOTARE, SE VENGONO USATE IN MANIERA CORRETTA, LE MANIGLIE PIAZZA NON RAGGIUNGONO MAI IL PUNTO CRITICO DEI 40°C (SOPRA IL QUALE LE MANI SI SCOTTANO) ANCHE QUANDO L'ACQUA È A 98°C.

THE GRAPHIC SHOWS THE VALUES OF THE TEMPERATURE REACHED BY PIAZZA'S HANDLES COMPARED TO THE ONE OF THE OTHER HANDLES ON THE MARKET. AS YOU SEE THE TEMPERATURE OF PIAZZA'S HANDLES NEVER REACHES THE CRITIC POINT OF 40°C EVEN WITH WATER AT 98°C, IF USED IN THE PROPER WAY. ABOVE THIS CRITIC POINT HANDS GET BURNT.



NEW



Casseruola bassa

Shallow cookpot

| Cod. | Ø cm | H cm | Lt |
|---------------|------|------|------|
| 096024 | 24 | 8 | 3,6 |
| 096028 | 28 | 9 | 5,6 |
| 096032 | 32 | 10 | 8,1 |
| 096036 | 36 | 11 | 11,3 |
| 096040 | 40 | 13 | 16,4 |
| 096045 | 45 | 14 | 22,4 |
| 096050 | 50 | 16 | 31,6 |



NEW



Casseruola media

Medium cookpot

| Cod. | Ø cm | H cm | Lt |
|---------------|------|------|------|
| 096216 | 16 | 8 | 1,6 |
| 096220 | 20 | 9 | 2,8 |
| 096224 | 24 | 10 | 4,5 |
| 096228 | 28 | 12 | 7,4 |
| 096232 | 32 | 15 | 12,1 |
| 096236 | 36 | 17 | 17,4 |
| 096240 | 40 | 19 | 24 |
| 096245 | 45 | 22 | 35,1 |
| 096250 | 50 | 25 | 49,3 |



NEW



Casseruola alta

Deep cookpot

| Cod. | Ø cm | H cm | Lt |
|---------------|------|------|------|
| 096416 | 16 | 11 | 2,2 |
| 096420 | 20 | 13 | 4,1 |
| 096424 | 24 | 15 | 6,8 |
| 096428 | 28 | 18 | 11,1 |
| 096432 | 32 | 20 | 16,1 |
| 096436 | 36 | 22 | 22,5 |
| 096440 | 40 | 25 | 31,5 |
| 096445 | 45 | 28 | 44,7 |
| 096450 | 50 | 32 | 63 |



NEW



Casseruola bassa 1 manico

Shallow saucepan

| Cod. | Ø cm | H cm | Lt |
|---------------|------|------|-----|
| 096124 | 24 | 8 | 3,6 |
| 096128 | 28 | 9 | 5,6 |



NEW



Casseruola media 1 manico

Medium saucepan

| Cod. | Ø cm | H cm | Lt |
|---------------|------|------|-----|
| 096316 | 16 | 8 | 1,6 |
| 096320 | 20 | 9 | 2,8 |
| 096324 | 24 | 10 | 4,5 |
| 096328 | 28 | 12 | 7,4 |



NEW



Casseruola alta 1 manico

Deep saucepan

| Cod. | Ø cm | H cm | Lt |
|-----------------|------|------|------|
| 096512 ← | 12 * | 8 | 0,9 |
| 096514 ← | 14 * | 9 | 1,4 |
| 096516 | 16 | 11 | 2,2 |
| 096520 | 20 | 13 | 4,1 |
| 096524 | 24 | 15 | 6,8 |
| 096528 | 28 | 18 | 11,1 |



* CON MANICO DIFFERENTE
WITH A DIFFERENT HANDLE

NEW



Pentola

| Pan | Cod. | Ø cm | H cm | Lt |
|-----|---------------|------|------|------|
| | 096620 | 20 | 20 | 6,3 |
| | 096624 | 24 | 24 | 10,9 |
| | 096628 | 28 | 28 | 17,3 |
| | 096632 | 32 | 32 | 25,8 |
| | 096636 | 36 | 36 | 36,7 |
| | 096640 | 40 | 40 | 50,3 |
| | 096645 | 45 | 45 | 71,7 |
| | 096650 | 50 | 50 | 98,3 |



NEW

Casseruola bombata

| Curved saute pan | Cod. | Ø cm | H cm | Lt |
|------------------|---------------|------|------|------|
| | 091216 | 16 | 6 | 1 |
| | 091218 | 18 | 6 | 1,2 |
| | 091220 | 20 | 6,5 | 1,5 |
| | 091222 | 22 | 7 | 1,95 |
| | 091224 | 24 | 7,5 | 2,5 |



NEW

Padella in acciaio con rivestimento antiaderente

| Steel frying pan with non-stick coating | Cod. | Ø cm | H cm |
|---|---------------|------|------|
| | 091720 | 20 | 4,5 |
| | 091724 | 24 | 5 |
| | 091728 | 28 | 5,5 |
| | 091732 | 32 | 6 |
| | 091736 | 36 * | 6,5 |
| | 091740 | 40 * | 7 |



* CON CONTROMANICO WITH A SECOND HANDLE



NEW

Wok con rivestimento antiaderente

| Wok with non-stick coating | Cod. | Ø cm | H cm |
|----------------------------|---------------|------|------|
| | 091928 | 28 | 9 |



NEW



Padella

| Frying pan | Cod. | Ø cm | H cm |
|------------|---------------|------|------|
| | 096720 | 20 | 4,5 |
| | 096724 | 24 | 5 |
| | 096728 | 28 | 5,5 |
| | 096732 | 32 | 6 |
| | 096736 | 36 | 6,5 |
| | 096740 | 40 * | 7 |
| | 096745 | 45 * | 7,5 |
| | 096750 | 50 * | 8 |



* CON CONTROMANICO WITH A SECOND HANDLE

NEW



Tegame

| 2-handled frying pan | Cod. | Ø cm | H cm |
|----------------------|---------------|------|------|
| | 096820 | 20 | 4,5 |
| | 096824 | 24 | 5 |
| | 096828 | 28 | 5,5 |
| | 096832 | 32 | 6 |
| | 096836 | 36 | 6,5 |
| | 096840 | 40 | 7 |
| | 096845 | 45 | 7,5 |
| | 096850 | 50 | 8 |



Coperchio

| Lid | Cod. | Ø cm |
|-----|---------------|------|
| | 092916 | 16 |
| | 092920 | 20 |
| | 092924 | 24 |
| | 092928 | 28 |
| | 092932 | 32 |
| | 092936 | 36 |
| | 092940 | 40 |
| | 092945 | 45 |
| | 092950 | 50 |





Casseruola bassa

| Shallow cookpot | Cod. | Ø cm | H cm | Lt |
|-----------------|---------------|------|------|------|
| | 093028 | 28 | 9 | 5,5 |
| | 093032 | 32 | 10 | 8 |
| | 093036 | 36 | 11 | 11,2 |
| | 093040 | 40 | 13 | 16,3 |
| | 093045 | 45 | 14 | 22,3 |
| | 093050 | 50 | 16 | 31,4 |



Casseruola media

| Medium cookpot | Cod. | Ø cm | H cm | Lt |
|----------------|---------------|------|------|------|
| | 093220 | 20 | 10,5 | 3,3 |
| | 093224 | 24 | 11 | 5 |
| | 093228 | 28 | 13 | 8 |
| | 093232 | 32 | 16 | 12,9 |



Casseruola alta

| Deep cookpot | Cod. | Ø cm | H cm | Lt |
|--------------|---------------|------|------|------|
| | 093416 | 16 | 12 | 2,4 |
| | 093420 | 20 | 14 | 4,4 |
| | 093424 | 24 | 16 | 7,2 |
| | 093428 | 28 | 18 | 11,1 |
| | 093432 | 32 | 20 | 16,1 |
| | 093436 | 36 | 22 | 22,4 |
| | 093440 | 40 | 25 | 31,4 |
| | 093445 | 45 | 28 | 44,5 |
| | 093450 | 50 | 32 | 62,8 |



Coperchio

| Lid | Cod. | Ø cm |
|-----|---------------|------|
| | 093916 | 16 |
| | 093920 | 20 |
| | 093924 | 24 |
| | 093928 | 28 |
| | 093932 | 32 |
| | 093936 | 36 |
| | 093940 | 40 |
| | 093945 | 45 |
| | 093950 | 50 |



Padella

| Frying pan | Cod. | Ø cm | H cm | Lt |
|------------|---------------|------|------|-----|
| | 093720 | 20 | 4 | 1,2 |
| | 093724 | 24 | 4 | 1,7 |
| | 093728 | 28 | 5 | 2,9 |
| | 093732 | 32 | 5 | 3,8 |
| | 093736 | 36 | 6,5 | 6,3 |
| | 093740 | 40 | 7 | 8,4 |



Casseruola media 1 manico

| Medium saucepan | Cod. | Ø cm | H cm | Lt |
|-----------------|---------------|------|------|-----|
| | 093316 | 16 | 9,5 | 1,9 |
| | 093320 | 20 | 10,5 | 3,3 |
| | 093324 | 24 | 11 | 5 |
| | 093328 | 28 | 12 | 7,5 |



Casseruola alta 1 manico

| Deep saucepan | Cod. | Ø cm | H cm | Lt |
|---------------|---------------|------|------|------|
| | 093516 | 16 | 12 | 2,4 |
| | 093520 | 20 | 14 | 4,4 |
| | 093524 | 24 | 16 | 7,2 |
| | 093528 | 28 | 18 | 11,1 |



Pentola

| Pan | Cod. | Ø cm | H cm | Lt |
|-----|---------------|------|------|------|
| | 093624 | 24 | 24 | 10,9 |
| | 093628 | 28 | 28 | 16 |
| | 093632 | 32 | 32 | 25,8 |
| | 093636 | 36 | 36 | 36,6 |
| | 093640 | 40 | 40 | 50,2 |
| | 093645 | 45 | 45 | 71,5 |





NEW

Tegame

2-handled frying pan

| Cod. | Ø cm | H cm |
|---------------|------|------|
| 096820 | 20 | 4,5 |
| 096824 | 24 | 5 |
| 096828 | 28 | 5,5 |
| 096832 | 32 | 6 |
| 096836 | 36 | 6,5 |
| 096840 | 40 | 7 |
| 096845 | 45 | 7,5 |
| 096850 | 50 | 8 |



NEW

Casseruola bombata

Curved saute pan

| Cod. | Ø cm | H cm | Lt |
|---------------|------|------|------|
| 091216 | 16 | 6 | 1 |
| 091218 | 18 | 6 | 1,2 |
| 091220 | 20 | 6,5 | 1,5 |
| 091222 | 22 | 7 | 1,95 |
| 091224 | 24 | 7,5 | 2,5 |



NEW

Padella in acciaio con rivestimento antiaderente

Steel frying pan with non-stick coating

| Cod. | Ø cm | H cm |
|---------------|------|------|
| 091720 | 20 | 4,5 |
| 091724 | 24 | 5 |
| 091728 | 28 | 5,5 |
| 091732 | 32 | 6 |
| 091736 | 36 * | 6,5 |
| 091740 | 40 * | 7 |



* CON CONTROMANICO
WITH A SECOND HANDLE



NEW

Wok con rivestimento antiaderente

Wok with non-stick coating

| Cod. | Ø cm | H cm |
|---------------|------|------|
| 091928 | 28 | 9 |



LE PADELLE ANTIADERENTI: PRATICHE, ROBUSTE, INALTERABILI

NON-STICK FRYING PANS: PRACTICAL, ROBUST, INALTERABLE



Le padelle antiaderenti **PIAZZA** vantano il trattamento di alta qualità **Teflon® Platinum Plus**.

La speciale tecnologia multistrato assicura prestazioni superiori in fase di cottura, impedisce ai cibi di attaccarsi al fondo e resiste in modo ottimale a graffi ed abrasioni, consentendo così l'utilizzo di accessori da cucina in metallo. Sono facili da pulire e possono essere tranquillamente lavate in lavastoviglie.

Our **PIAZZA** non-stick frying pans are all subject to the high quality **Teflon® Platinum Plus** treatment. The special multi-layer technology guarantees superior performance during cooking, preventing food from sticking to the base and providing optimal resistance against scratches and abrasion, whilst also allowing metal kitchen utensils to be used. Our frying pans are easy to clean and are all fully dishwasher-safe.

| | |
|---|------------------------|
| TEMPERATURA OTTIMALE DI COTTURA OPTIMAL COOKING TEMPERATURE | 240° C (464° F) |
| TEMPERATURA MASSIMA DI UTILIZZO MAXIMUM USE TEMPERATURE | 340° C (644° F) |

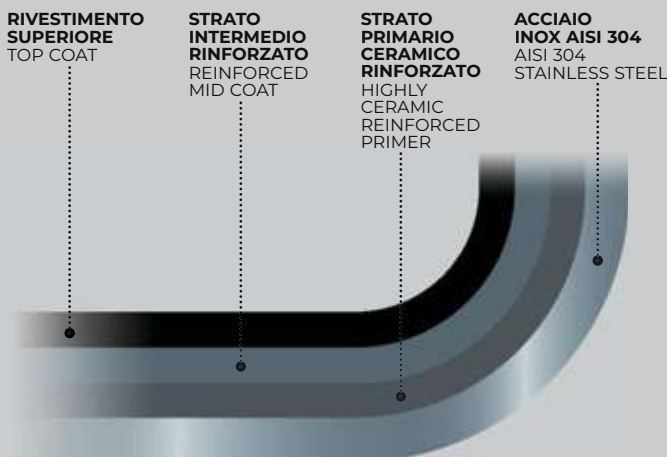

Teflon® è un marchio commerciale registrato di E.I. Du Pont de Nemours and Company
Teflon® is a registered trademark of E.I. Du Pont de Nemours and Company



Rostiera rettangolare alta

| High rectangular roaster | Cod. | L x W cm | Lt |
|--------------------------|---------------|----------|------|
| | 101525 | 25 x 18 | 3 |
| | 101530 | 30 x 22 | 4 |
| | 101535 | 35 x 25 | 6 |
| | 101540 | 40 x 28 | 9 |
| | 101545 | 45 x 30 | 13 |
| | 101550 | 50 x 35 | 17,5 |
| | 101560 | 60 x 40 | 27 |



Vassoio rettangolare

| Rectangular tray | Cod. | L x W cm |
|------------------|---------------|----------|
| | 101630 | 30 x 23 |
| | 101635 | 35 x 28 |
| | 101640 | 40 x 30 |
| | 101645 | 45 x 35 |
| | 101650 | 50 x 35 |
| | 101655 | 55 x 35 |
| | 101660 | 60 x 40 |



Casseruola bassa

| Shallow cookpot | Cod. | Ø cm | H cm | Lt |
|-----------------|---------------|------|------|------|
| | 102024 | 24 | 8 | 3,6 |
| | 102028 | 28 | 9,3 | 5,6 |
| | 102032 | 32 | 10,6 | 8,1 |
| | 102036 | 36 | 12 | 11,3 |
| | 102040 | 40 | 13,3 | 16,4 |
| | 102045 | 45 | 15 | 22,4 |
| | 102050 | 50 | 16,6 | 31,6 |



Casseruola media

| Medium cookpot | Cod. | Ø cm | H cm | Lt |
|----------------|---------------|------|------|-----|
| | 102220 | 20 | 10 | 3 |
| | 102224 | 24 | 12 | 5,5 |
| | 102228 | 28 | 14 | 8,5 |
| | 102232 | 32 | 16 | 13 |
| | 102236 | 36 | 18 | 18 |
| | 102240 | 40 | 20 | 25 |
| | 102245 | 45 | 22,5 | 36 |
| | 102250 | 50 | 25 | 49 |



Casseruola media 1 manico

| Medium saucepan | Cod. | Ø cm | H cm | Lt |
|-----------------|---------------|------|------|-----|
| | 102316 | 16 | 8 | 1,5 |
| | 102320 | 20 | 10 | 3 |
| | 102324 | 24 | 12 | 5,5 |
| | 102328 | 28 | 14 | 8,5 |



Casseruola alta

| Deep cookpot | Cod. | Ø cm | H cm | Lt |
|--------------|---------------|------|------|------|
| | 102420 | 20 | 13,3 | 4 |
| | 102424 | 24 | 16 | 7 |
| | 102428 | 28 | 18,6 | 11,5 |
| | 102432 | 32 | 21,3 | 17 |
| | 102436 | 36 | 24 | 24,5 |
| | 102440 | 40 | 26,6 | 34 |





Casseruola alta 1 manico

| Deep saucepan | Cod. | Ø cm | H cm | Lt |
|---------------|---------------|------|------|----|
| | 102516 | 16 | 10,6 | 2 |
| | 102520 | 20 | 13,3 | 4 |
| | 102524 | 24 | 16 | 7 |



Pentola

| Pan | Cod. | Ø cm | H cm | Lt |
|-----|---------------|------|------|------|
| | 102620 | 20 | 20 | 6 |
| | 102624 | 24 | 24 | 11 |
| | 102628 | 28 | 28 | 17 |
| | 102632 | 32 | 32 | 26 |
| | 102636 | 36 | 36 | 37 |
| | 102640 | 40 | 40 | 50 |
| | 102645 | 45 | 45 | 71,5 |
| | 102650 | 50 | 50 | 98 |



Padella svasata bassa

| Shallow flared frying pan | Cod. | Ø cm | H cm |
|---------------------------|---------------|------|------|
| | 102720 | 20 | 4,5 |
| | 102724 | 24 | 5 |
| | 102728 | 28 | 5,5 |
| | 102732 | 32 | 6 |
| | 102736 | 36 | 6,5 |
| | 102740 | 40 | 7 |



Padella svasata alta

| Deep frying pan | Cod. | Ø cm | H cm |
|-----------------|----------------|------|------|
| | 1027200 | 20 | 5 |
| | 1027240 | 24 | 6 |
| | 1027280 | 28 | 6,5 |
| | 1027320 | 32 | 7 |
| | 1027360 | 36 | 7,5 |
| | 1027400 | 40 | 8,5 |



Tegame

| 2-handed frying pan | Cod. | Ø cm | H cm |
|---------------------|---------------|------|------|
| | 102820 | 20 | 4,5 |
| | 102824 | 24 | 6 |
| | 102828 | 28 | 6,5 |
| | 102832 | 32 | 7 |
| | 102836 | 36 | 7,5 |
| | 102840 | 40 | 8 |
| | 102845 | 45 | 8 |
| | 102850 | 50 | 8 |



Coperchio

| Lid | Cod. | Ø cm |
|-----|---------------|------|
| | 102916 | 16 |
| | 102920 | 20 |
| | 102924 | 24 |
| | 102928 | 28 |
| | 102932 | 32 |
| | 102936 | 36 |
| | 102940 | 40 |
| | 102945 | 45 |
| | 102950 | 50 |





Casseruola bassa antiaderente

Shallow cookpot with non-stick coating

| Cod. | Ø cm | H cm | Lt |
|---------------|------|------|-----|
| 105024 | 24 | 8 | 3,5 |
| 105028 | 28 | 9,5 | 6 |
| 105032 | 32 | 10,5 | 8,5 |



Casseruola media antiaderente

Medium cookpot with non-stick coating

| Cod. | Ø cm | H cm | Lt |
|---------------|------|------|-----|
| 105220 | 20 | 10 | 3 |
| 105224 | 24 | 12 | 5,5 |
| 105228 | 28 | 14 | 8,5 |



Casseruola media 1 manico antiaderente

Medium saucepan with non-stick coating

| Cod. | Ø cm | H cm | Lt |
|---------------|------|------|-----|
| 105316 | 16 | 8 | 1,5 |
| 105320 | 20 | 10 | 3 |
| 105324 | 24 | 12 | 5,5 |



Padella svasata bassa antiaderente

Shallow flared frying pan with non-stick coating

| Cod. | Ø cm | H cm |
|---------------|------|------|
| 105724 | 24 | 5 |
| 105728 | 28 | 5,5 |
| 105732 | 32 | 6 |
| 105736 | 36 | 6,5 |
| 105740 | 40 | 7 |



Padella svasata alta antiaderente

Deep frying pan with non-stick coating

| Cod. | Ø cm | H cm |
|----------------|------|------|
| 1057200 | 20 | 5 |
| 1057240 | 24 | 6 |
| 1057280 | 28 | 6,5 |
| 1057320 | 32 | 7 |
| 1057360 | 36 | 7,5 |
| 1057400 | 40 | 8,5 |



Tegame svasato antiaderente

Flared pan with non-stick coating

| Cod. | Ø cm | H cm |
|---------------|------|------|
| 105824 | 24 | 6 |
| 105828 | 28 | 6,5 |
| 105832 | 32 | 7 |
| 105836 | 36 | 7,5 |
| 105840 | 40 | 8 |



Le collezioni di pentolame multistrato 3-PLY e 4-PLY sfruttano le diverse peculiarità dei singoli materiali che le compongono.

Nascono così assortimenti completi, studiati per offrirvi prestazioni di assoluta eccellenza, senza rinunciare a praticità e maneggevolezza in ogni situazione di preparazione e servizio, in cucina come in sala.

- SPESSORE 1,2 MM (3-PLY) E 2 MM (4-PLY)
- BORDO A VERSARE
- UTILIZZABILI SU OGNI TIPO DI PIASTRA DI COTTURA (GAS, INDUZIONE, ELETTRICA, VETROCERAMICA) GARANTENDO SEMPRE CONDUCIBILITÀ OTTIMALE
- LA PERFETTA ERGONOMIA DEL MANICO IN ACCIAIO INOX CONSENTE UNA PRESA SEMPRE SICURA E CONFORTEVOLE
- IL PROFILO DELLA SALDATURA DI MANICO E MANIGLIE OFFRE GARANZIA DI MASSIMA TENUTA MENTRE L'APERTURA SUPERIORE NE PERMETTE IL RAFFREDDAMENTO GRAZIE AL PASSAGGIO DELL'ARIA. IL DISEGNO APERTO FORNISCE INOLTRE LA MASSIMA IGIENICITÀ IN FASE DI LAVAGGIO
- NELLA COLLEZIONE 4-PLY IL FONDO IN ACCIAIO NON È APPLICATO, MA MESSO A NUDO RIMUOVENDO LO STRATO ESTERNO IN RAME, PER OFFRIRE ROBUSTEZZA E DURATA NEL TEMPO
- NEI DIAMETRI DA 8 A 16 CM IL COPERCHIO PUÒ ESSERE COMODAMENTE AGGANCIATO AL BORDO DELLE CASSERUOLE GRAZIE AL PARTICOLARE DISEGNO DEL TRAVERSINO

The multi-layer cookware collections 3-PLY and 4-PLY takes advantage of the different peculiarities of the materials they are made of.

The results are complete ranges, designed to bring you excellent performance.

Always practical and easy to use in kitchen and in service room.

- THICK 1.2 MM (3-PLY) AND 2 MM (4-PLY)
- POURING EDGE
- SUITABLE FOR GAS, INDUCTION, HOTPLATES AND CERAMIC, ALWAYS MAINTAINING HIGH CONDUCTIVITY
- ERGONOMIC HANDLES IN STAINLESS STEEL DESIGNED TO GIVE A SAFE AND COMFORTABLE GRIP
- THE SHAPE OF WELDING OF THE HANDLES ENSURES THE BEST SEALING WHILE THE UPPER OPENING ALLOWS COOLING. THE OPEN OUTLINE GUARANTEES THE EXCELLENT HYGIENE
- THE STEEL BOTTOM IS NOT APPLIED, YET EXPOSED BY REMOVING THE EXTERNAL COPPER LAYER: THIS RESULTS IN GREATER STRENGTH AND LONG-LIFE
- THE LIDS WITH DIAMETERS FROM 8 TO 16 CM CAN BE EASILY HOOKED TO THE RIM OF THE CASSEROLES THANKS TO THE SPECIAL DESIGN OF THE KNOB





Casseruola bassa

Shallow cookpot

| Cod. | Ø cm | H cm | Lt |
|---------------|------|------|-----|
| 110028 | 28 | 9 | 5,6 |
| 110032 | 32 | 10 | 8 |



Casseruola media

Medium cookpot

| Cod. | Ø cm | H cm | Lt |
|-----------------|------|------|------|
| 110210 ← | 10 | 4,5 | 0,35 |
| 110212 ← | 12 | 6 | 0,7 |
| 110214 ← | 14 | 7 | 1 |
| 110216 ← | 16 | 8 | 1,6 |
| 110220 | 20 | 9 | 2,8 |
| 110224 | 24 | 10 | 4,5 |
| 110228 | 28 | 12 | 7,4 |



Casseruola alta

Deep cookpot

| Cod. | Ø cm | H cm | Lt |
|-----------------|------|------|------|
| 110408 ← | 8 | 5 | 0,25 |
| 110410 ← | 10 | 6,5 | 0,5 |
| 110412 ← | 12 | 8 | 0,9 |
| 110414 ← | 14 | 9 | 1,4 |
| 110416 ← | 16 | 11 | 2,2 |
| 110420 | 20 | 13 | 4,1 |
| 110424 | 24 | 15 | 6,8 |
| 110428 | 28 | 18 | 11 |
| 110432 | 32 | 20 | 16 |
| 110436 | 36 | 22 | 22,5 |

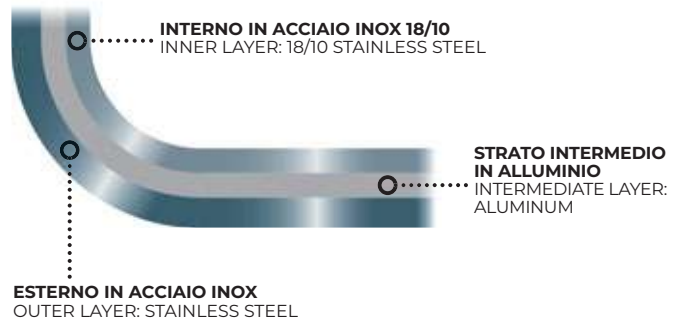

Casseruola media 1 manico

Medium saucepan

| Cod. | Ø cm | H cm | Lt |
|---------------|------|------|------|
| 110310 | 10 | 4,5 | 0,35 |
| 110312 | 12 | 6 | 0,7 |
| 110314 | 14 | 7 | 1 |
| 110316 | 16 | 8 | 1,6 |



Casseruola alta 1 manico

Deep saucepan

| Cod. | Ø cm | H cm | Lt |
|---------------|------|------|------|
| 110508 | 8 | 5 | 0,25 |
| 110510 | 10 | 6,5 | 0,5 |
| 110512 | 12 | 8 | 0,9 |
| 110514 | 14 | 9 | 1,4 |





Padella

| Frying pan | Cod. | Ø cm | H cm |
|------------|-----------------|------|------|
| | 110710 ← | 10 | 3 |
| | 110712 ← | 12 | 3 |
| | 110714 ← | 14 | 3 |
| | 110716 ← | 16 | 3 |
| | 110720 | 20 | 4,5 |
| | 110724 | 24 | 5 |
| | 110728 | 28 | 5,5 |
| | 110732 | 32 | 6 |
| | 110736 | 36 | 6 |



Tegame

| Two-handed frying pan | Cod. | Ø cm | H cm |
|-----------------------|---------------|------|------|
| | 110810 | 10 | 3 |
| | 110812 | 12 | 3 |
| | 110814 | 14 | 3 |
| | 110816 | 16 | 3 |



Casseruola bombata

| Curved saute pan | Cod. | Ø cm | H cm | Lt |
|------------------|---------------|------|------|-----|
| | 111218 | 18 | 6,5 | 1,2 |
| | 111220 | 20 | 7 | 1,5 |
| | 111222 | 22 | 7,5 | 1,9 |
| | 111224 | 24 | 8 | 2,5 |



Padella antiaderente

| Frying pan non-stick | Cod. | Ø cm | H cm |
|----------------------|---------------|------|------|
| | 111720 | 20 | 4,5 |
| | 111724 | 24 | 5 |
| | 111728 | 28 | 5,5 |
| | 111732 | 32 | 6 |
| | 111736 | 36 | 6 |
| | 111740 | 40 * | 6,5 |



* CON CONTROMANICO
WITH A SECOND HANDLE



Coperchio

| Lid | Cod. | Ø cm |
|-----|-----------------|------|
| | 112908 ← | 8 |
| | 112910 ← | 10 |
| | 112912 ← | 12 |
| | 112914 ← | 14 |
| | 112916 ← | 16 |
| | 092920 | 20 |
| | 092924 | 24 |
| | 092928 | 28 |
| | 092932 | 32 |
| | 092936 | 36 |
| | 092940 | 40 |





Casseruola media

Medium cookpot

| Cod. | Ø cm | H cm | Lt |
|--------|------|------|------|
| 113210 | 10 | 4,5 | 0,25 |
| 113212 | 12 | 6 | 0,5 |
| 113214 | 14 | 7 | 0,9 |
| 113216 | 16 | 8 | 1,4 |



Casseruola alta

Deep cookpot

| Cod. | Ø cm | H cm | Lt |
|--------|------|------|------|
| 113408 | 8 | 5 | 0,2 |
| 113410 | 10 | 6,5 | 0,4 |
| 113412 | 12 | 8 | 0,75 |
| 113414 | 14 | 9 | 1,2 |
| 113416 | 16 | 11 | 2 |



Padella

Frying pan

| Cod. | Ø cm | H cm |
|--------|------|------|
| 113710 | 10 | 3,5 |
| 113712 | 12 | 3,5 |
| 113714 | 14 | 3,5 |
| 113716 | 16 | 3,5 |



Tegame

Two-handed frying pan

| Cod. | Ø cm | H cm |
|--------|------|------|
| 113810 | 10 | 3 |
| 113812 | 12 | 3 |
| 113814 | 14 | 3 |
| 113816 | 16 | 3 |



Coperchio

Lid

| Cod. | Ø cm |
|--------|------|
| 112908 | 8 |
| 112910 | 10 |
| 112912 | 12 |
| 112914 | 14 |
| 112916 | 16 |

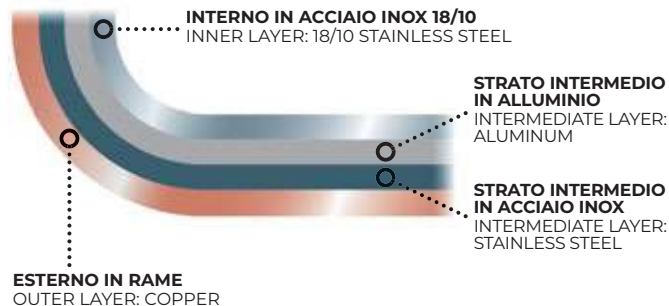







Spicchio per casseruola alta

Strainer for deep
casserole

| Cod. | Por. | Ø cm |
|---------------|------|------|
| 120128 | 1/3 | 28 |
| 120132 | 1/3 | 32 |
| 120136 | 1/4 | 36 |
| 120140 | 1/4 | 40 |



Spicchio a rete per casseruola alta

Mesh strainer
for deep casserole

| Cod. | Por. | Ø cm |
|---------------|------|------|
| 120228 | 1/3 | 28 |
| 120232 | 1/3 | 32 |
| 120236 | 1/4 | 36 |
| 120240 | 1/4 | 40 |



Scaldapasta

Warmer

| Cod. | Ø cm |
|---------------|------|
| 120318 | 18 |
| 120320 | 20 |
| 120324 | 24 |
| 120328 | 28 |



Chinois con gancio di appoggio anteriore

Chinois

| Cod. | Ø cm |
|---------------|------|
| 120516 | 16 |
| 120518 | 18 |
| 120520 | 20 |
| 120524 | 24 |



Chinois a rete

Chinois

| Cod. | Ø cm |
|---------------|------|
| 120620 | 20 |
| 120624 | 24 |



Chinois a rete con protezione in filo

Chinois wire protection

| Cod. | Ø cm |
|---------------|------|
| 120720 | 20 |
| 120724 | 24 |





Tazzone con manico tubolare

| Kitchen bowl | Cod. | Ø cm | cl |
|--------------|---------------|------|-----|
| | 120916 | 16 | 125 |
| | 120918 | 18 | 150 |
| | 120920 | 20 | 200 |
| | 120922 | 22 | 300 |
| | 120924 | 24 | 500 |



Tazzone tondo con manico tubolare

| Round kitchen bowl | Cod. | Ø cm | cl |
|--------------------|---------------|------|-----|
| | 121016 | 16 | 125 |
| | 121018 | 18 | 150 |
| | 121020 | 20 | 200 |



Bagnomaria

| Bain marie pot | Cod. | Ø cm | H cm | cl |
|----------------|---------------|------|------|-----|
| | 121212 | 12 | 14 | 150 |
| | 121214 | 14 | 16 | 250 |
| | 121216 | 16 | 18 | 350 |
| | 121218 | 18 | 20 | 500 |
| | 121220 | 20 | 22 | 700 |



Timballo per dolci

| Pie mould | Cod. | Ø cm | H cm | cl |
|-----------|---------------|------|------|----|
| | 121506 | 5 | 5 | 6 |
| | 121511 | 6 | 6 | 11 |
| | 121515 | 6,5 | 6,5 | 15 |
| | 121517 | 7 | 7 | 17 |
| | 121528 | 8 | 8 | 28 |



Misurino graduato

| Measuring jug | Cod. | cl |
|---------------|---------------|-----|
| | 121605 | 50 |
| | 121610 | 100 |
| | 121620 | 200 |



DIMENSIONI REALI
REAL DIMENSIONS

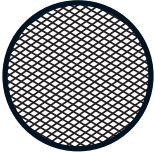

FORI HOLES
1 x 0,7 mm



Setaccio inox a velo

Stainless steel
fine sieve

| Cod. | Ø cm |
|---------------|------|
| 121721 | 21 |
| 121730 | 30 |
| 121735 | 35 |



DIMENSIONI REALI
REAL DIMENSIONS

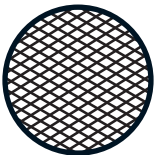

FORI HOLES
2 x 1,15 mm



Setaccio inox farina

Stainless steel
flour sieve

| Cod. | Ø cm |
|---------------|------|
| 121821 | 21 |
| 121830 | 30 |
| 121835 | 35 |



DIMENSIONI REALI
REAL DIMENSIONS

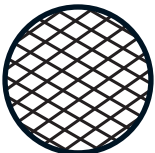

FORI HOLES
3,35 x 2,15 mm



Setaccio inox pane

Stainless steel bread
crumbs sieve

| Cod. | Ø cm |
|---------------|------|
| 121930 | 30 |
| 121935 | 35 |



DIMENSIONI REALI
REAL DIMENSIONS

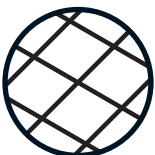

FORI HOLES
9,8 x 7,5 mm



Setaccio inox pesce

Stainless steel
fish sieve

| Cod. | Ø cm |
|---------------|------|
| 122030 | 30 |
| 122035 | 35 |



Bacinella

Bowl

| Cod. | Ø cm | H cm | cl |
|---------------|------|------|------|
| 130116 | 16,5 | 6,5 | 75 |
| 130120 | 20,5 | 8 | 150 |
| 130125 | 25 | 10,5 | 300 |
| 130127 | 27 | 11 | 400 |
| 130129 | 29,5 | 12,5 | 500 |
| 130133 | 33,5 | 13,5 | 800 |
| 130139 | 39,5 | 16 | 1400 |



**Bacinella per pasticceria
e cucina bordata**

Bowl

| Cod. | Ø cm | H cm | cl |
|---------------|------|------|------|
| 130616 | 16 | 9 | 100 |
| 130618 | 18 | 9 | 150 |
| 130621 | 21 | 10 | 200 |
| 130625 | 25 | 12,5 | 375 |
| 130628 | 28,5 | 13 | 500 |
| 130633 | 33 | 14,5 | 800 |
| 130637 | 37 | 16 | 1000 |
| 130641 | 41 | 18 | 1500 |



Colapasta conico in alluminio

Aluminium conical
pasta strainer

| Cod. | Ø cm |
|---------------|------|
| 135635 | 35 |
| 135640 | 40 |
| 135645 | 45 |
| 135650 | 50 |





Placca alluminio microforata

| | | | |
|----------------------------------|---------------|----------|------|
| Micro-perforated aluminium plate | Cod. | L x W cm | H cm |
| | 251030 | 30 x 40 | 1 |
| | 251032 | 32 x 53 | 1 |
| | 251060 | 40 x 60 | 1 |



Teglia cottura ferro blu diamantata con X di rinforzo

| | | | |
|--|---------------|----------|------|
| Blue iron baking tray with reinforcement X | Cod. | L x W cm | H cm |
| | 252063 | 40 x 60 | 2 |



Teglia cottura ferro blu con pareti dritte

| | | | |
|---|---------------|----------|------|
| Blue iron baking tray with straight edges | Cod. | L x W cm | H cm |
| | 252060 | 40 x 60 | 2 |



Teglia cottura alluminio forata

| | | | |
|----------------------------------|---------------|----------|------|
| Perforated aluminium baking tray | Cod. | L x W cm | H cm |
| | 252161 | 40 x 60 | 2 |



Teglia cottura alluminata con pareti dritte

| | | | |
|--|---------------|----------|------|
| Aluminized baking tray with straight edges | Cod. | L x W cm | H cm |
| | 252061 | 40 x 60 | 2 |



Teglia cottura tonda ferro blu

| | | | |
|-----------------------------|---------------|------|------|
| Round blue iron baking tray | Cod. | Ø cm | H cm |
| | 252514 | 14 | 2,5 |
| | 252516 | 16 | 2,5 |
| | 252518 | 18 | 2,5 |
| | 252520 | 20 | 2,5 |
| | 252522 | 22 | 2,5 |
| | 252524 | 24 | 2,5 |
| | 252526 | 26 | 2,5 |
| | 252528 | 28 | 2,5 |
| | 252530 | 30 | 2,5 |
| | 252532 | 32 | 2,5 |
| | 252536 | 36 | 2,5 |
| | 252540 | 40 | 2,5 |
| | 252545 | 45 | 2,5 |
| | 252550 | 50 | 2,5 |



Teglia cottura alluminata antiaderente con pareti dritte

| | | | |
|--|---------------|----------|------|
| Aluminized baking tray with non stick coating and straight edges | Cod. | L x W cm | H cm |
| | 252062 | 40 x 60 | 2 |





Teglia cottura alluminio

| Round baking tray | Cod. | Ø cm | H cm |
|-------------------|---------------|------|------|
| | 252521 | 20 | 2,5 |
| | 252525 | 24 | 2,5 |
| | 252529 | 28 | 2,5 |
| | 252533 | 32 | 2,5 |



Teglia cottura alluminio

| Aluminium baking tray | Cod. | L x W cm | H cm |
|-----------------------|---------------|----------|------|
| | 253135 | 35 x 35 | 3 |
| | 253140 | 30 x 40 | 3 |
| | 253150 | 35 x 50 | 3 |
| | 253160 | 40 x 60 | 3 |



Teglia cottura ferro blu

| Blue iron baking tray | Cod. | L x W cm | H cm |
|-----------------------|---------------|----------|------|
| | 253030 | 23 x 30 | 3 |
| | 253035 | 28 x 35 | 3 |
| | 253040 | 30 x 40 | 3 |
| | 253045 | 35 x 45 | 3 |
| | 253050 | 35 x 50 | 3 |
| | 253060 | 40 x 60 | 3 |
| | 253065 | 45 x 65 | 3 |



Tortiera alta ferro blu

| Blue iron high-sided cake pan | Cod. | Ø cm | H cm |
|-------------------------------|---------------|------|------|
| | 254014 | 14 | 4 |
| | 254016 | 16 | 4 |
| | 254018 | 18 | 4 |
| | 254020 | 20 | 4 |
| | 254022 | 22 | 4 |
| | 254024 | 24 | 4 |
| | 254026 | 26 | 4 |
| | 254028 | 28 | 4 |
| | 254030 | 30 | 4 |
| | 254032 | 32 | 4 |
| | 254036 | 36 | 4 |
| | 254040 | 40 | 4 |
| | 254045 | 45 | 4 |
| | 254050 | 50 | 4 |
| | 254060 | 60 | 4 |



Teglia cottura ferro blu con pareti svasate

| Blue iron baking tray with flared corners | Cod. | L x W cm | H cm |
|---|---------------|----------|------|
| | 253041 | 30 x 40 | 3 |
| | 253061 | 40 x 60 | 3 |



**Mestolo unipezzo inox 18/10**Ladle one piece
inox 18/10

| Cod. | Ø cm | L cm | cl |
|---------------|------|------|------|
| 150006 | 6 * | 31 | 6 |
| 150007 | 7 | 34,5 | 8 |
| 150008 | 8 | 36 | 12,5 |
| 150009 | 9 | 36 | 19 |
| 150010 | 10 | 43 | 25 |
| 150012 | 12 | 52 | 50 |
| 150014 | 14 | 55 | 75 |
| 150016 | 16 | 61 | 100 |
| 150018 | 18 | 64 | 150 |
| 150020 | 20 | 72 | 200 |



* CON BECCO WITH BEAK

**Schiumarola unipezzo inox 18/10**Skimmer one piece
inox 18/10

| Cod. | Ø cm | L cm |
|---------------|------|------|
| 150108 | 8 | 33,5 |
| 150110 | 10 | 43,5 |
| 150112 | 12 | 47,5 |
| 150114 | 14 | 50,5 |
| 150116 | 16 | 55,5 |
| 150118 | 18 | 58,5 |
| 150120 | 20 | 65,5 |

**Forchettone a due punte unipezzo inox 18/10**Meat fork one piece
inox 18/10

| Cod. | L cm |
|---------------|------|
| 150242 | 42 |
| 150253 | 53 |

**Paletta con fori unipezzo inox 18/10**Perforated lifter one
piece inox 18/10

| Cod. | L x W cm | L cm |
|---------------|----------|------|
| 150300 | 11 x 14 | 47,5 |

**Paletta senza fori unipezzo inox 18/10**Lifter one piece
inox 18/10

| Cod. | L x W cm | L cm |
|---------------|----------|------|
| 150400 | 11 x 14 | 47,5 |

**Schiumarola a rete saldata inox 18/10**Mesh welded skimmer
inox 18/10

| Cod. | Ø cm | L cm |
|---------------|------|------|
| 152300 | 15 | 54 |

**Cucchiaione fondo unipezzo inox 18/10**Deep spoon one piece
inox 18/10

| Cod. | L x W cm | L cm |
|---------------|----------|------|
| 150800 | 11 x 7 | 40,5 |

**Cucchiaione fondo manico di costa unipezzo inox 18/10**Deep side spoon
one piece inox 18/10

| Cod. | L x W cm | L cm |
|---------------|----------|------|
| 150900 | 11 x 7 | 37 |

**Cucchiaione unipezzo inox 18/10**Large spoon one piece
inox 18/10

| Cod. | L x W cm | L cm |
|---------------|----------|------|
| 151100 | 9,5 x 7 | 33,5 |

**Cucchiaione con fori unipezzo inox 18/10**Perforated large spoon
one piece inox 18/10

| Cod. | L x W cm | L cm |
|---------------|----------|------|
| 151200 | 9,5 x 7 | 33,5 |





**Mestolo unipezzo**

Ladle one piece

| Cod. | Ø cm | L cm | cl |
|---------------|------|------|------|
| 153006 | 6 | 37 | 6 |
| 153008 | 8 | 39 | 12,5 |
| 153010 | 10 | 45 | 25 |
| 153012 | 12 | 50 | 50 |
| 153014 | 14 | 54 | 75 |
| 153016 | 16 | 60 | 100 |

**Paletta con fori unipezzo**

Perforated lifter one piece

| Cod. | L x W cm | L cm |
|---------------|----------|------|
| 153400 | 10 x 9 | 48 |

**Paletta unipezzo**

Lifter one piece

| Cod. | L x W cm | L cm |
|---------------|----------|------|
| 153401 | 10 x 9 | 48 |

**Schiumarola unipezzo**

Skimmer one piece

| Cod. | Ø cm | L cm |
|---------------|------|------|
| 153108 | 8 | 36 |
| 153110 | 10 | 42 |
| 153112 | 12 | 48 |
| 153114 | 14 | 53 |
| 153116 | 16 | 57 |

**Cucchiaione fondo unipezzo**

Deep spoon one piece

| Cod. | L x W cm | L cm | cl |
|---------------|----------|------|----|
| 153800 | 10 x 7 | 47 | |

**Forchettone unipezzo**

Meat fork one piece

| Cod. | L cm |
|---------------|------|
| 153242 | 50 |

**Cucchiaione fondo manico di costa unipezzo**

Deep side spoon one piece

| Cod. | L x W cm | L cm | cl |
|---------------|----------|------|----|
| 153900 | 7 x 10 | 44 | |





NEW

Spatola professionale in nylon rinforzato con fiberglass

| Professional spatula in nylon reinforced with fiberglass | Cod. | L cm | Box |
|--|---------------|------|-----|
| | 285021 | 30 | 6 |
| | 285022 | 35 | 6 |
| | 285023 | 40 | 6 |

FINO A UP TO +260°C

Spatola professionale "Vasetto" in plastica

| Professional plastic spatula for jar | Cod. | L cm |
|--------------------------------------|---------------|------|
| | 285000 | 25 |



FINO A UP TO +160°C



Spatola professionale in plastica

| Professional plastic spatula | Cod. | L cm |
|------------------------------|---------------|------|
| | 285001 | 25 |
| | 285002 | 35 |
| | 285003 | 45 |



FINO A UP TO +160°C



Spatola professionale applicazione in silicone

| Professional spatula with silicone blade | Cod. | L cm |
|--|---------------|------|
| | 285012 | 35 |



FINO A UP TO +300°C



SPATOLE IN PLASTICA: IDEALI IN OGNI PREPARAZIONE
 PLASTIC SPATULAS: IDEAL IN ALL KINDS OF PREPARATION

Le spatole professionali in plastica di **PIAZZA** vantano caratteristiche che le rendono ideali per tutte le situazioni di preparazione. Robuste e leggere al tempo stesso, l'ottima flessibilità dell'applicazione consente loro di adattarsi perfettamente ad ogni tipo di angolo.

- MANICO IN MATERIALE COMPOSITO (POLIAMMIDE E FIBERGLASS) RESISTENTE FINO A +220°C
- APPLICAZIONI RESISTENTI ALLE ALTE TEMPERATURE - SILICONE FINO A +300°C - COPOLIESTERE TERMOPLASTICO FINO A +160°C
- IDEALI PER L'USO SU FONDI ANTIADERENTI
- STERILIZZABILI E LAVABILI IN LAVASTOVIGLIE
- PROGETTATE E SVILUPPATE DA **PIAZZA**
- TOTALMENTE PRODOTTE IN ITALIA



PIAZZA'S professional, plastic spatulas have special features that make them ideal for all kinds of food preparation. Sturdy and light at the same time and the great flexibility of the blade enables them to adapt perfectly to every type of angle.

- HANDLE IN COMPOSITE MATERIAL (POLYAMIDE AND GLASS FIBRE), RESISTANT UP TO +220°C / 428°F
- BLADES RESISTANT TO HIGH TEMPERATURES - SILICONE UP TO +300°C / 572°F - THERMOPLASTIC COPOLYESTER UP TO +160°C / 320°F
- PERFECT FOR USE ON NON-STICK SURFACES
- CAN BE STERILISED AND ARE DISHWASHER FRIENDLY
- DESIGNED AND DEVELOPED BY **PIAZZA**
- ENTIRELY MANUFACTURED IN ITALY



**Cucchiaione nylon & fiberglass**

Design by Michele Capuani

Nylon & fiberglass
large spoon

Cod.

156000

L cm

38

156100

30

**Forchettone 2 punte nylon & fiberglass**

Design by Michele Capuani

Nylon & fiberglass
meat fork 2 prongs

Cod.

15723400

L cm

34

**Mestolo nylon & fiberglass
con becco a versare**

Design by Michele Capuani

Nylon & fiberglass
ladle with beak

Cod.

15700600

Ø cm

6

L cm

31

cl

4

**Mestolo nylon & fiberglass**

Design by Michele Capuani

Nylon & fiberglass ladle

Cod.

15700800

Ø cm

8

L cm

33

cl

10

15701000

10

35

20

**Mestolo pizza nylon & fiberglass**

Design by Michele Capuani

Nylon & fiberglass
pizza ladle

Cod.

15790900

Ø cm

9

L cm

35

cl

17

**Schiumarola nylon & fiberglass**

Design by Michele Capuani

Nylon & fiberglass
skimmer

Cod.

15711000

Ø cm

10

L cm

33

15711200

12

35

**Cucchiaione liscio nylon & fiberglass**

Design by Michele Capuani

Nylon & fiberglass
large spoon

Cod.

15780000

L cm

35

**Cucchiaione forato nylon & fiberglass**

Design by Michele Capuani

Nylon & fiberglass
perforated large spoon

Cod.

15780100

L cm

35



THE SPECIAL MIX NYLON & FIBERGLASS

La nuova linea di mestolame PIAZZA nasce interamente in Italia. Lo speciale polimero con cui viene prodotta: una combinazione di nylon e fibra di vetro, ne garantisce praticità d'uso e durata nel tempo.

- LA PARTICOLARE FORMA DEI MANICI UNISCE MASSIMA ROBUSTEZZA E GRANDE LEGGEREZZA
- DIMENSIONE DEI FORI DIFFERENZIATA A SECONDA DELL'UTILIZZO
- PERFETTAMENTE RESISTENTE AL CALORE FINO A 220°C
- LAVABILE IN LAVASTOVIGLIE: IGIENICITÀ GARANTITA

PIAZZA new ladle line is fully made in Italy. It is made of a special polymer, a combination of nylon and fiberglass, that gives great guarantee of lasting in time and ease of use.

- THE UNIQUE SHAPE OF THE HANDLES COMBINE MAXIMUM STRENGTH AND GREAT LIGHTNESS
- HOLES' DIMENSIONS DIVERSIFIED ACCORDING TO THE USE
- PERFECTLY HEAT-RESISTANT UP TO 220°C (430°F)
- DISHWASHER SAFE: HYGIENICALLY GUARANTEED



Paletta liscia nylon & fiberglass

Design by Michele Capuani

| | | | |
|---------------------------|-----------------|----------|------|
| Nylon & fiberglass lifter | Cod. | L x W cm | L cm |
| | 15740000 | 9,5 x 11 | 35 |



Paletta forata nylon & fiberglass

Design by Michele Capuani

| | | | |
|--------------------------------------|-----------------|----------|------|
| Nylon & fiberglass perforated lifter | Cod. | L x W cm | L cm |
| | 15740100 | 9,5 x 11 | 35 |



Paletta hamburger nylon & fiberglass

Design by Michele Capuani

| | | | |
|-------------------------------------|-----------------|----------|------|
| Nylon & fiberglass hamburger lifter | Cod. | L x W cm | L cm |
| | 15740200 | 9 x 13 | 34 |



Cucchiaino nylon & fiberglass

| | | | | |
|--------------------------|---------------|------|------|-----|
| Nylon & fiberglass spoon | Cod. | L cm | Col. | Box |
| | 155002 | 34 | ○ | 12 |
| | 155007 | 34 | ● | 12 |



Cucchiaino forato nylon & fiberglass

| | | |
|-----------------------------------|---------------|------|
| Nylon & fiberglass draining spoon | Cod. | L cm |
| | 155107 | 34 |



**Spatola angolare**

Design by Michele Capuani

| Angular spatula | Cod. | L cm |
|-----------------|---------------|------|
| | 240010 | 10 |
| | 240022 | 22 |
| | 240026 | 26 |
| | 240030 | 30 |
| | 240036 | 36 |

**Spatola angolare appuntita**

Design by Michele Capuani

| Tapered point angular spatula | Cod. | L cm |
|-------------------------------|---------------|------|
| | 240011 | 11 |

**Spatola dritta**

Design by Michele Capuani

| Spatula | Cod. | L cm |
|---------|---------------|------|
| | 240112 | 12 |
| | 240115 | 15 |
| | 240120 | 20 |
| | 240122 | 22 |
| | 240126 | 26 |
| | 240130 | 30 |
| | 240136 | 36 |

**Spatola triangolare**

Design by Michele Capuani

| Triangle spatula | Cod. | W x L cm |
|------------------|---------------|----------|
| | 240208 | 8 x 12 |
| | 240210 | 10 x 12 |
| | 240212 | 12 x 12 |

**Spatola forata**

Design by Michele Capuani

| Perforated spatula | Cod. | W x L cm |
|--------------------|---------------|----------|
| | 240300 | 7,5 x 16 |

**Spatola per hamburger**

Design by Michele Capuani

| Hamburger turner | Cod. | W x L cm |
|------------------|---------------|----------|
| | 240400 | 7 x 24 |
| | 240401 | 14 x 19 |

**Spatola per pizza**

Design by Michele Capuani

| Pizza turner | Cod. | W x L cm |
|--------------|---------------|----------|
| | 240501 | 9 x 15,5 |

**Tagliapasta**

Design by Michele Capuani

| Dough cutter | Cod. | W x L cm |
|--------------|---------------|----------|
| | 240600 | 16 x 12 |





Raschia Design by Michele Capuani
Scraper

| | |
|---------------|----------|
| Cod. | W x L cm |
| 240601 | 12 x 9,5 |
| 240640 | 15 x 7,5 |



Raschia Design by Michele Capuani
Scraper

| | |
|---------------|----------|
| Cod. | W x L cm |
| 240700 | 15 x 6 |



Tronchetto tagliapizza Design by Michele Capuani
Pizza cutter

| | |
|---------------|----------|
| Cod. | W x L cm |
| 240800 | 14 x 6 |



Rotella tagliapizza Design by Michele Capuani
Pizza wheel cutter

| | |
|---------------|------|
| Cod. | Ø cm |
| 241106 | 5,5 |
| 241110 | 10 |



Paletta pizza ovale forata Design by Michele Capuani
Oval perforated pizza turner

| | |
|---------------|----------|
| Cod. | W x L cm |
| 240900 | 18 x 22 |



Paletta pizza ovale Design by Michele Capuani
Oval pizza turner

| | |
|---------------|----------|
| Cod. | W x L cm |
| 240901 | 18 x 22 |



Paletta pizza triangolare forata Design by Michele Capuani
Triangle perforated pizza turner

| | |
|---------------|----------|
| Cod. | W x L cm |
| 241000 | 12 x 16 |



Paletta pizza triangolare Design by Michele Capuani
Triangle pizza turner

| | |
|---------------|----------|
| Cod. | W x L cm |
| 241001 | 12 x 16 |

Grattugia inox manico antiscivolo



UNIVERSALE ALL-IN-ONE

Stainless steel grater non slip handle

| | | |
|---------------|----------|------|
| Cod. | L x W cm | L cm |
| 160145 | 2,5 x 20 | 33 |



Grattugia inox manico antiscivolo



EXTRA SPESSA EXTRA COARSE

Stainless steel grater non slip handle

| | | |
|---------------|----------|------|
| Cod. | L x W cm | L cm |
| 160151 | 3,5 x 22 | 38,5 |



Grattugia inox manico antiscivolo



SEMI FINE MEDIUM COARSE

Stainless steel grater non slip handle

| | | |
|---------------|----------|------|
| Cod. | L x W cm | L cm |
| 160152 | 3,5 x 22 | 38,5 |



Grattugia inox manico antiscivolo



FINE FINE

Stainless steel grater non slip handle

| | | |
|---------------|----------|------|
| Cod. | L x W cm | L cm |
| 160153 | 3,5 x 22 | 38,5 |



Grattugia inox manico antiscivolo



FINE FINE

Stainless steel grater non slip handle

| | | |
|---------------|------------|------|
| Cod. | L x W cm | L cm |
| 160170 | 6,5 x 13,5 | 31,5 |



Grattugia inox manico antiscivolo



SPESSA COARSE

Stainless steel grater non slip handle

| | | |
|---------------|------------|------|
| Cod. | L x W cm | L cm |
| 160171 | 6,5 x 13,5 | 31,5 |



Grattugia inox manico antiscivolo



MEDIA RIBBON

Stainless steel grater non slip handle

| | | |
|---------------|------------|------|
| Cod. | L x W cm | L cm |
| 160172 | 6,5 x 13,5 | 31,5 |



Grattugia inox manico antiscivolo



SCAGLIE GRANDI LARGE SHAVER

Stainless steel grater non slip handle

| | | |
|---------------|------------|------|
| Cod. | L x W cm | L cm |
| 160173 | 6,5 x 13,5 | 31,5 |



Grattugia inox manico antiscivolo



ULTRA SPESSA ULTRA COARSE

Stainless steel grater non slip handle

| | | |
|---------------|------------|------|
| Cod. | L x W cm | L cm |
| 160174 | 6,5 x 13,5 | 31,5 |



- 9 DIFFERENTI TIPI DI LAMA PER COPRIRE OGNI ESIGENZA
- LAME IN ACCIAIO INOX CON MASSIMA EFFICACIA DI TAGLIO
- MANICO ERGONOMICO IN MATERIALE ANTISCIVOLO
- PIEDINO D'APPOGGIO IN GOMMA E CUSTODIA PARALAMA DI SICUREZZA
- 9 DIFFERENT BLADES TO FULLFILL EVERY NEED
- STAINLESS STEEL BLADES WITH FLAWLESS PRECISION
- ERGONOMIC HANDLE WITH NON-SLIP GRIP
- RUBBER FEET AND BLADE COVER FOR YOUR SAFETY



LE LAME THE BLADES

UNIVERSALE ALL-IN-ONE

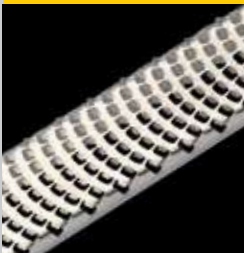

IDEALE PER:
AGRUMI,
FORMAGGIO,
ZENZERO,
CIOCCOLATO,
TARTUFO,
FRUTTA SECCA

BEST FOR:
CITRUS FRUITS,
CHEESE,
CHOCOLATE,
GINGER, TRUFFLE,
DRIED FRUIT

EXTRA SPESSE EXTRA COARSE



IDEALE PER:
MELE, PATATE,
BURRO,
FORMAGGIO,
ZUCCHINE,
CAROTE,
FRUTTA SECCA

BEST FOR:
APPLES, CARROTS,
POTATOES,
CHEESE, BUTTER,
ZUCCHINI,
DRIED FRUIT

SEMI FINE MEDIUM COARSE

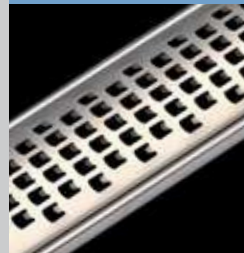

IDEALE PER:
FORMAGGIO,
ZENZERO,
PEPERONCINO,
COCCO,
CIOCCOLATO

BEST FOR:
CHEESE,
CHILI PEPPER,
GINGER,
COCONUT,
CHOCOLATE

FINE FINE



IDEALE PER:
AGRUMI,
FORMAGGIO,
AGLIO,
PEPERONCINO,
CANNELLA,
FRUTTA SECCA

BEST FOR:
CITRUS FRUITS,
CHEESE, GARLIC,
CHILI PEPPER,
CINNAMON,
DRIED FRUIT

FINE FINE



IDEALE PER:
AGRUMI,
AGLIO,
FORMAGGIO,
PEPERONCINO,
CANNELLA,
FRUTTA SECCA

BEST FOR:
CITRUS FRUITS,
CHEESE, GARLIC,
CHILI PEPPER,
CINNAMON,
DRIED FRUIT

SPESSE COARSE

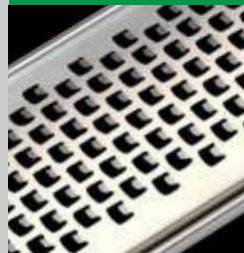

IDEALE PER:
COCCO,
CAROTE,
ZENZERO,
FRUTTA SECCA,
FORMAGGIO

BEST FOR:
CHEESE,
CARROTS,
GINGER,
COCONUT,
DRIED FRUIT

MEDIA RIBBON



IDEALE PER:
FORMAGGIO,
MELE, BURRO,
ZUCCHINE,
CAROTE,
CIOCCOLATO,

BEST FOR:
CHEESE,
CHOCOLATE,
APPLES,
CARROTS,
ZUCCHINI,
BUTTER

SCAGLIE GRANDI LARGE SHAVER



IDEALE PER:
TARTUFO,
ZUCCHINE
CIOCCOLATO,
FORMAGGIO,
BURRO

BEST FOR:
TRUFFLE,
ZUCCHINI
CHOCOLATE,
CHEESE,
BUTTER

ULTRA SPESSE ULTRA COARSE



IDEALE PER:
ZUCCHINE,
BURRO,
CIOCCOLATO,
FORMAGGIO,
TARTUFO

BEST FOR:
CHEESE,
BUTTER,
ZUCCHINI,
CHOCOLATE,
TRUFFLE



Grattugia inox

Stainless steel grater

| Cod. | L cm |
|--------|------|
| 160109 | 9 |
| 160113 | 13 |
| 160116 | 16 |

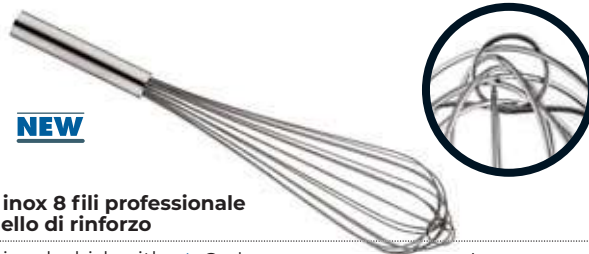

NEW

Frusta inox 8 fili professionale con anello di rinforzo

Professional whisk with reinforcement ring

| Cod. | L cm |
|--------|------|
| 160530 | 30 |
| 160535 | 35 |
| 160540 | 40 |
| 160545 | 45 |
| 160550 | 50 |
| 160560 | 60 |



Grattugia quattro lati

Grater four side

| Cod. | L x W cm | H cm |
|--------|----------|------|
| 160300 | 8 x 6 | 18 |



Guanto super rinforzato

Extra reinforced gloves

| Cod. | Range |
|--------|--------------|
| 161800 | fino a 240°C |

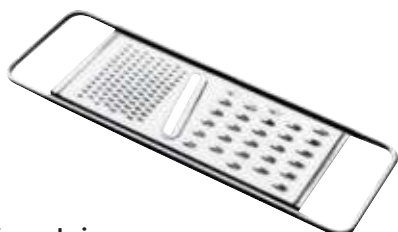

Grattugia universale inox

Stainless steel universal grater

| Cod. | L x W cm |
|--------|----------|
| 160200 | 11 x 28 |



Coppia guanti rinforzati

Professional reinforced gloves

| Cod. | Range |
|--------|--------------|
| 161900 | fino a 180°C |



Frusta inox 8 fili professionale senza anello

Professional whisk without ring

| Cod. | L cm |
|--------|------|
| 160625 | 25 |
| 160630 | 30 |



Coppia manopole da forno polso lungo in pelle ovina

Pair of professional reinforced gloves in kid leather

| Cod. | Range |
|--------|--------------|
| 162001 | fino a 250°C |





Riga limone

Lemon grater

Cod. **163400** L cm 14



Arriccia burro

Butter-curler

Cod. **163900** L cm 16



Decora limone

Lemon decorator

Cod. **163500** L cm 14,5



Scavino 2 coppe

Melon baller-double

Cod. **164100** L cm 16,5



Coltello per pelare

Peeling knife

Cod. **163600** L cm 14,5



Scavino 1 coppa

Melon baller

Cod. **164200** L cm 13



Sbuccia arancia

Orange peeler

Cod. **163700** L cm 14,5



Sbucciaverdure ad archetto

Vegetable peeler

Cod. **164400** L cm 12,5



Levator solo

Apple corer

Cod. **163800** L cm 17,5





Batticarne a pugno inox

| Solid stainless steel meat beater | Cod. | W kg |
|-----------------------------------|---------------|------|
| | 165310 | 1 |
| | 165315 | 1,5 |
| | 165320 | 2 |
| | 165325 | 2,5 |



Gancio girevole inox

| Swivel stainless steel hook with balls on both sides | Cod. | L x W mm | Box |
|--|---------------|----------|-----|
| | 165621 | 210 x 9 | 15 |
| | 165624 | 240 x 10 | 15 |
| | 165627 | 270 x 12 | 15 |
| | 165650 | 500 x 12 | 15 |



Batticarne a due tagli inox

| Stainless steel meat beater - 2 cuts | Cod. | W kg |
|--------------------------------------|---------------|------|
| | 165400 | 1,1 |



Gancio fisso una punta inox

| Standard stainless steel hook 1 point | Cod. | L x W mm | Box |
|---------------------------------------|---------------|----------|-----|
| | 165706 | 60 x 3 | 100 |
| | 165808 | 80 x 4 | 50 |
| | 165810 | 100 x 4 | 50 |
| | 165912 | 120 x 5 | 10 |
| | 165914 | 140 x 5 | 10 |
| | 166016 | 160 x 6 | 10 |
| | 166018 | 180 x 6 | 10 |
| | 166218 | 180 x 8 | 10 |
| | 166530 | 300 x 12 | 5 |



Batticarne a paletta inox

| Stainless steel round ladle-type meat beater with bent handle | Cod. | W kg |
|---|---------------|------|
| | 165500 | 1 |



Gancio ad ancora inox 1 punta

| Stainless steel anchor-type hook 1 point | Cod. | L x W mm | Box |
|--|---------------|----------|-----|
| | 166707 | 130 x 7 | 10 |



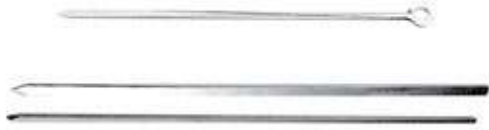

Spiedini inox

| Stainless steel skewer | Cod. | L x W mm | Box |
|------------------------|---------------|----------|-----|
| | 166820 | 200 x 3 | 6 |
| | 166825 | 250 x 3 | 6 |
| | 166830 | 300 x 3 | 6 |
| | 166920 | 200 x 4 | 6 |
| | 166925 | 250 x 4 | 6 |
| | 166930 | 300 x 4 | 6 |



Set di spiedini inox con decoro animale

| Set of stainless steel skewers with animal decoration | Cod. | L x W mm |
|---|---------------|----------|
| | 167000 | 300 x 30 |



Sega per ossa inox fissaggio rapido

| Stainless steel saw, quick-fit | Cod. | L cm | Box |
|--------------------------------|---------------|------|-----|
| | 167145 | 45 | 3 |
| | 167150 | 50 | 3 |



Ricambio lama sega per ossa fiss. rapido

| Saw blade | Cod. | L cm | Box |
|-----------|---------------|------|-----|
| | 167240 | 40 | 3 |
| | 167245 | 45 | 3 |
| | 167250 | 50 | 3 |
| | 167255 | 55 | 3 |



Morsa prosciutto base in legno

| Ham vice | Cod. |
|----------|---------------|
| | 167300 |



Ceppo inox con piano in plastica piedini inox antiscivolo

| Stainless steel chopping block with plastic top | Cod. | L x W cm | H cm |
|---|---------------|----------|------|
| | 167440 | 40 x 40 | 90 |
| | 167450 | 50 x 50 | 90 |
| | 167460 | 60 x 60 | 90 |





**Portavivande per frigorifero
(senza coperchio)**

| Food carrier (lid not included) | Cod. | L x W cm | H cm |
|------------------------------------|---------------|-------------|------|
| | 170000 | 9,5 x 9,5 | 6 |
| | 170200 | 9,5 x 19,5 | 6 |
| | 170400 | 19,5 x 19,5 | 6 |
| | 170600 | 20 x 29 | 7 |



Coperchio per portavivande per frigorifero

| Lid for food carrier | Cod. | L x W cm | Per/For |
|----------------------|---------------|-------------|---------|
| | 170100 | 9,5 x 9,5 | 170000 |
| | 170300 | 9,5 x 19,5 | 170200 |
| | 170500 | 19,5 x 19,5 | 170400 |
| | 170700 | 20 x 29 | 170600 |



**PIATTI ESPOSITORI IN ACCIAIO INOX:
PRATICI E PROFESSIONALI**

STAINLESS STEEL DISPLAY TRAYS:
PRACTICAL AND PROFESSIONAL

- ELEVATA RESISTENZA ALLA CORROSIONE
- FACILITÀ DI PULIZIA E LUNGA DURATA NEL TEMPO
- GARANZIA DI MASSIMA IGIENICITÀ
- TOTALMENTE PRODOTTI IN ITALIA
- IDEALI PER ESPORRE CIBI SIA CALDI CHE FREDDI
- HIGH RESISTANCE TO CORROSION
- EASE OF CLEANING AND LONG-LASTING DURABILITY
- GUARANTEE OF MAXIMUM HYGIENE,
- ENTIRELY MANUFACTURED IN ITALY
- IDEAL FOR DISPLAYING BOTH HOT AND COLD FOODS



**Platto espositore
per pasticceria e gastronomia**

| Display tray | Cod. | L x W cm | H cm |
|--------------|---------------|-----------|------|
| | 180114 | 14,5 x 21 | 2 |
| | 180129 | 29 x 21 | 2 |
| | 180158 | 58 x 21 | 2 |





Mandolina con carrello

Professional vegetable cutter with safety guard

Cod.

195100



Set lame per mandolina

Set of blades for vegetable slicer

Cod.

195500

Set per/for **195400**

195600

Set per/for **195100**

Cod. 195500

Cod. 195600



Mandolina affetta verdure

Professional vegetable cutter

Cod.

195200



Affettaverdure rotante "le rouet"

Rotating vegetable slicer "le rouet"

Cod.

195700



Carrello per mandolina

Safety guard

Cod.

195300



Mandolina "gourmet"

Manual vegetable slicer

Cod.

195400



Affettapane con tagliere in legno

Bread cutter with wood

Cod.

196200



Scavino pulisci pomodoro

Tomato seeds remover

Cod.

195900



Grattugia fine

Grater

Cod.

196500





Coltello cuoco

| Chef knife | Cod. | L cm |
|------------|---------------------|------|
| | 8115-1461F12 | 15 |
| | 8115-1461F05 | 21 |
| | 8115-1461F60 | 23 |
| | 8115-1461F61 | 25 |



Coltello trinciante

| Carving knife | Cod. | L cm |
|---------------|---------------------|------|
| | 8115-1461F04 | 21 |
| | 8115-1461F57 | 25 |



Coltello filettare

| Fillet knife | Cod. | L cm |
|--------------|---------------------|------|
| | 8115-1461F09 | 18 |



Coltello multiuso

| Utility knife | Cod. | L cm |
|---------------|---------------------|------|
| | 8115-1461F03 | 13 |



Coltello multiuso lama larga

| Utility knife | Cod. | L cm |
|---------------|---------------------|------|
| | 8115-1461F70 | 14 |



Spelucchino

| Paring knife | Cod. | L cm |
|--------------|---------------------|------|
| | 8115-1461F01 | 9 |



Spelucchino lama curva

| Curved paring knife | Cod. | L cm |
|---------------------|---------------------|------|
| | 8115-1461F17 | 8 |



LA TRADIZIONE ORIENTALE NEL TRATTAMENTO DELLE LAME SI UNISCE ALLA ROBUSTEZZA DELL'ACCIAIO TEDESCO
ORIENTAL TRADITION IN THE TREATMENT OF BLADE JOINS THE STRENGTH OF GERMAN STEEL

PREMIUM SERIES COLTELLI FORGIATI FORGED KNIVES



L'acciaio dei coltelli Atlantic Chef è acciaio tedesco 1.4116-X50 Cr Mo V15. La combinazione di Carbonio, Cromo, Molibdeno, Vanadio e altri materiali, conferisce alla lama una durezza di HRC 56' e oltre, fornendo rigidità ed elasticità al tempo stesso, aumentando la resistenza alla corrosione e ottimizzando l'efficacia di taglio. La levigatura manuale garantisce infine la lunga durata del filo della lama, una facile manutenzione e una veloce riaffilatura. I coltelli Atlantic Chef sono inoltre tutti certificati NSF® International.

PER GARANTIRE RESISTENZA E DURATA NEL TEMPO, MANICO E LAMA SONO FORGIATI A PARTIRE DA UN UNICO PEZZO DI ACCIAIO. CIÒ FORNISCE INOLTRE A OGNI SINGOLO PEZZO UNA BILANCIATURA PERFETTA CHE NE FACILITA L'UTILIZZO E RIDUCE LA FATICA.

HANDLE AND BLADE ARE FORGED FROM A SINGLE PIECE OF STEEL, WHICH PROVIDES STRENGTH AND A LONG USEFUL LIFE. ADDITIONALLY, EACH KNIFE IS PERFECTLY BALANCED: THIS HELPS ITS EASY USE AND REDUCES EFFORT.

MANICI IN DUPONT™ DELRIN® POM, UNA RESINA ACETALICA CON CARATTERISTICHE UNICHE DI RIGIDITÀ E RESISTENZA AGLI URTI RIPETUTI, ALL'ABRASIONE E ALL'UMIDITÀ. SONO PERFETTAMENTE ADERENTI AL MANICO E AI RIVETTI, OFFRENDO MASSIMA IGIENICITÀ.

HANDLES ARE MADE OF DUPONT™ DELRIN® POM, AN ACETAL RESIN FEATURING UNIQUE CHARACTERISTICS OF STIFFNESS AND RESISTANCE TO REPEATED SHOCKS, ABRASION AND HUMIDITY. THEY PERFECTLY STICK TO THE HANDLE AND RIVETS, ASSURING TOP HYGIENE.



Coltello Santoku

Santoku knife

| | |
|---------------------|------|
| Cod. | L cm |
| 8115-1461F38 | 18 |



Coltello arrosto

Slicing knife

| | |
|----------------------|------|
| Cod. | L cm |
| 8115-1461F109 | 28 |



Coltello Usuba

Usuba knife

| | |
|---------------------|------|
| Cod. | L cm |
| 8115-1461F46 | 18 |



Forchettone curvo

Carving fork - curved

| | |
|---------------------|------|
| Cod. | L cm |
| 8115-1461F11 | 16 |



Coltello disosso

Boning knife

| | |
|---------------------|------|
| Cod. | L cm |
| 8115-1461F10 | 15 |



Coltello pane

Bread knife

| | |
|---------------------|------|
| Cod. | L cm |
| 8115-1461F06 | 21 |
| 8115-1461F53 | 23 |



Coltello pomodoro lama dentata

Tomato knife - serrated edge

| | |
|---------------------|------|
| Cod. | L cm |
| 8115-1461F14 | 14 |



EFFICIENT SERIES COLTELLI STAMPATI
STAMPED KNIVES



Atlantic Chef uses German Steel 1.4116-X50 Cr Mo V15, which consists of Carbon, Chromium, Vanadium, Molybdenum and several other materials. After hardening/tempering, grinding, sharpening and some other major processes, the hardness of the blades can reach as high as HRC 56' and above. Knives are simultaneously strong and flexible, and this increases their cutting power and resistance to corrosion. The hand-honed razor sharp blade edge also offers long lasting sharpness, easy edge maintenance and rapid re-sharpening features. All the knives are certified by NSF® International.

GRAZIE A PROCESSI PRODUTTIVI AVANZATI E DI MASSIMA PRECISIONE, L'ACCOPIAMENTO FRA MANICO E LAMA RISULTA SEMPRE PERFETTAMENTE COMPATTO, GARANTENDO IGIENE E SOLIDITÀ OTTIMALI.

THANKS TO ADVANCED AND PRECISE PRODUCTIVE PROCESSES THE JOINING BETWEEN HANDLE AND BLADE ARE ALWAYS PERFECT AND SOLID.

I MANICI SONO REALIZZATI CON LA COMBINAZIONE DI SANTOPRENE® (UNO SPECIALE ELASTOMERO DALLE DOTI ANTISCIVOLO) E POLIPROPILENE. OFFRONO PRESA SICURA, TOTALE CONTROLLO DEL COLTELLO E MASSIMA ROBUSTEZZA.

THE HANDLES, MADE BY A COMBINATION OF SANTOPRENE® (A SPECIAL ELASTOMER WITH NON-GRIP FEATURES) AND POLYPROPYLENE, OFFER NON-SLIP ERGONOMIC GRIP, TOTAL CONTROL OF THE KNIFE AND MAXIMUM STRENGTH.



Coltello cuoco

Chef knife



| Cod. | L cm | Col. |
|----------------|------|------|
| 8100-8321T12 | 15 | ● |
| 8100-8321T05 | 21 | ● |
| 8100-8321T05BL | 21 | ● |
| 8100-8321T05G | 21 | ● |
| 8100-8321T05R | 21 | ● |
| 8100-8321T05W | 21 | ○ |
| 8100-8321T05Y | 21 | ● |
| 8100-8321T60 | 23 | ● |
| 8100-8321T61 | 25 | ● |
| 8100-8321T61BL | 25 | ● |
| 8100-8321T61BR | 25 | ● |
| 8100-8321T61G | 25 | ● |
| 8100-8321T61R | 25 | ● |
| 8100-8321T61W | 25 | ○ |
| 8100-8321T61Y | 25 | ● |
| 8100-8321T62 | 30 | ● |
| 8100-8321T62BL | 30 | ● |
| 8100-8321T62BR | 30 | ● |
| 8100-8321T62G | 30 | ● |
| 8100-8321T62R | 30 | ● |
| 8100-8321T62W | 30 | ○ |
| 8100-8321T62Y | 30 | ● |



Coltello multiuso lama dentata

Utility knife
Serrated edge

| Cod. | L cm |
|----------------|------|
| 8150-8321SS132 | 13 |



Coltello cuoco lama dentata

Chef knife
Serrated edge

| Cod. | L cm |
|---------------|------|
| 8100-8321T137 | 21 |
| 8100-8321T143 | 23 |
| 8100-8321T144 | 25 |



Coltello cuoco lama obliqua

Wide chef knife

| Cod. | L cm |
|---------------|------|
| 8100-8321T115 | 21 |



PER ALCUNI SPECIFICI MODELLI È PREVISTA LA DISPONIBILITÀ ANCHE DI MANICI COLORATI IN ACCORDO CON LA NORMATIVA HACCP

SOME SPECIFIC ITEMS ARE AVAILABLE ALSO WITH COLOURED HANDLES ACCORDING TO HACCP REGULATIONS



Coltello multiuso

Utility knife

| Cod. | L cm |
|--------------|------|
| 8100-8321T70 | 15 |



Coltello filettare - flessibile

Fillet knife - flexible

| Cod. | L cm | Col. |
|----------------|------|------|
| 8100-8321T09 | 18 | ● |
| 8100-8321T71 | 21 | ● |
| 8100-8321T71BL | 21 | ● |



Coltello Santoku

Santoku knife

| Cod. | L cm |
|--------------|------|
| 8100-8321T38 | 19 |



Coltello Usuba

Usuba knife

| Cod. | L cm |
|--------------|------|
| 8100-8321T46 | 18 |





Coltello disosso

Boning knife

| Cod. | L cm | Col. |
|-----------------------|------|------|
| 8100-8321T10 | 15 | ● |
| 8100-8321T10BL | 15 | ● |
| 8100-8321T10R | 15 | ● |
| 8100-8321T10Y | 15 | ● |



Spelucchino

Paring knife

| Cod. | L cm | Col. |
|-----------------------|------|------|
| 8150-8321SS01 | 8 | ● |
| 8150-8321SS01G | 8 | ● |
| 8150-8321SS01W | 8 | ○ |
| 8150-8321SS02 | 11 | ● |



Coltello disosso - Flessibile

Boning knife - Flexible

| Cod. | L cm |
|---------------------|------|
| 8100-8321T66 | 15 |



Spelucchino lama dentata

Paring knife serrated edge

| Cod. | L cm | Col. |
|-----------------------|------|------|
| 8150-8321SS36 | 8 | ● |
| 8150-8321SS36G | 8 | ● |
| 8150-8321SS36W | 8 | ○ |



Coltello disosso stretto

Wide boning knife

| Cod. | L cm |
|----------------------|------|
| 8100-8321T133 | 13 |



Spelucchino verdure lama curva

Curved paring knife

| Cod. | L cm | Col. |
|-----------------------|------|------|
| 8150-8321SS17 | 7 | ● |
| 8150-8321SS17G | 7 | ● |
| 8150-8321SS17W | 7 | ○ |



Coltello disosso stretto - Flessibile

Narrow boning knife Flexible

| Cod. | L cm |
|---------------------|------|
| 8100-8321T69 | 15 |



Coltello tavola

Utility knife - Round top

| Cod. | L cm | Col. |
|-----------------------|------|------|
| 8150-8321SS03 | 11 | ● |
| 8150-8321SS03G | 11 | ● |
| 8150-8321SS03W | 11 | ○ |



Coltello disosso curvo

Curved boning knife

| Cod. | L cm |
|---------------------|------|
| 8100-8321T64 | 15 |



Coltello arrostato

Slicer knife

| Cod. | L cm |
|----------------------|------|
| 8100-8321T136 | 23 |







Forchettone curvo

Carving fork - Curved

| | |
|---------------------|------|
| Cod. | L cm |
| 8100-8321T11 | 21 |



Forchettone dritto

Carving fork - Straight

| | |
|---------------------|------|
| Cod. | L cm |
| 8100-8321T28 | 18 |



Coltello formaggio punta quadra

Cheese slicer

| | |
|----------------------|------|
| Cod. | L cm |
| 8100-8321T135 | 31 |



Coltello pane

Bread knife

| | | |
|----------------------|------|------|
| Cod. | L cm | Col. |
| 8100-8321T06 | 21 | ● |
| 8100-8321T06W | 21 | ○ |
| 8100-8321T134 | 25 | ● |



Coltello salmone

Salmon knife

| | |
|---------------------|------|
| Cod. | L cm |
| 8100-8321T19 | 26 |



Coltello pane con scalino

Offset bread knife

| | |
|---------------------|------|
| Cod. | L cm |
| 8100-8321T15 | 21 |



Coltello salmone lama alveolata

Salmon knife
granton edge

| | |
|---------------------|------|
| Cod. | L cm |
| 8100-8321T77 | 26 |



Coltello pane con scalino e punta arrotondata

Offset bread knife
Round top

| | |
|----------------------|------|
| Cod. | L cm |
| 8100-8321T106 | 21 |



Coltello prosciutto

Slicing knife

| | |
|----------------------|------|
| Cod. | L cm |
| 8100-8321T108 | 30 |



Coltello pane lama inclinata

Wide bread knife

| | |
|---------------------|------|
| Cod. | L cm |
| 8100-8321T59 | 25 |



Coltello prosciutto lama alveolata

Slicing knife
granton edge

| | | |
|----------------------|------|------|
| Cod. | L cm | Col. |
| 8100-8321T73 | 28 | ● |
| 8100-8321T73W | 28 | ○ |
| 8100-8321T68 | 36 | ● |



Coltello panettiere

Slicing knife
Serrated edge

| | | |
|----------------------|------|------|
| Cod. | L cm | Col. |
| 8100-8321T72 | 28 | ● |
| 8100-8321T72W | 28 | ○ |
| 8100-8321T100 | 30 | ● |
| 8100-8321T101 | 36 | ● |





Coltello dolce

Cake knife

| Cod. | L cm |
|---------------------|------|
| 8100-8320T30 | 40 |
| 8100-8320T31 | 45 |



Forbici

Scissors

| Cod. |
|---------------------|
| 8155-9300T01 |



Coltello dolce lama dentata

Cake knife
Serrated edge

| Cod. | L cm |
|---------------------|------|
| 8100-8320T32 | 40 |
| 8100-8320T40 | 45 |



Custodia

Knife guard

| Cod. | Per/For |
|-----------------------|----------------|
| 8190-8321SS02 | 8150-8321SS02 |
| 8190-8321SS132 | 8150-8321SS132 |
| 8190-8321SS17 | 8150-8321SS17 |
| 8190-8321T09 | 8100-8321T09 |
| 8190-8321T100 | 8100-8321T100 |
| 8190-8321T133 | 8100-8321T133 |
| 8190-8321T134 | 8100-8321T134 |
| 8190-8321T135 | 8100-8321T135 |
| 8190-8321T136 | 8100-8321T136 |
| 8190-8321T60 | 8100-8321T60 |



Set decorazione cocktail - 7 pezzi

Cocktail decoration set
7 pieces

| Cod. |
|-----------------------|
| 8151-9100G7001 |

| | | | |
|--|--|--|--------------------------------------|
| | COLTELLO KNIFE | | LEVATORSOLO APPLE CORER |
| | SBUCCIA ARANCIA ORANGE PEELER | | RIGA LIMONE LEMON GRATER |
| | SCAVINO MELONE MELON BALLER | | DECORA LIMONE LEMON DECORATOR |
| | COLTELLO PER PELARE PEELING KNIFE | | |



Acciaino tondo

Sharpening steel

| Cod. | L cm |
|--------------------|------|
| 8153-TD1312 | 30 |



Set per intaglio e decorazione - 8 pezzi

Carving tool set
8 pieces

| Cod. |
|-----------------------|
| 8151-9100G8001 |

| | | | |
|--|-----------------------|--|------------------------------------|
| | COLTELLO KNIFE | | SCAVINO MELONE MELON BALLER |
| | COLTELLO KNIFE | | ACCIAINO SHARPENING STONE |



Affilacoltelli manuale

Hand held knife sharpener

| Cod. |
|-------------------|
| 8154-SH001 |



MASSIMA EFFICACIA E IGIENE PERFETTA
MAX EFFICIENCY AND PERFECT HYGIENE

I taglieri in Polietilene HD sono adatti a tutti gli ambiti HACCP.
Grazie alla loro superficie, totalmente liscia, e alla totale assenza di coloranti garantiscono massima efficacia d'uso e perfetta igiene.
Nella confezione inoltre sono compresi 7 fermi e 5 viti di montaggio per classificare a vostro piacere l'utilizzo del tagliere secondo la normativa HACCP.

These HD polyethylene cutting boards are suitable for all HACCP areas.

Max efficiency and perfect hygiene guaranteed thanks to the super smooth surface and total absence of colouring.

Each pack also contains 7 coloured stoppers and 5 screws letting you colour code each board for use in a specific HACCP area.



1
MONTARE IL PRIMO FERMO (SEMPRE BIANCO)
INSERT THE FIRST STOPPER (ALWAYS WHITE)



2
MONTARE IL SECONDO FERMO (COLORE HACCP)
INSERT THE SECOND STOPPER (HACCP COLOUR)



Tagliere in polietilene HD

| Polyethylene cutting board | Cod. | L x W cm | H cm |
|----------------------------|---------------|----------|------|
| | 208000 | 40 x 30 | 2 |
| | 208100 | 50 x 30 | 2 |
| | 208200 | 50 x 40 | 2 |
| | 208300 | 60 x 40 | 2 |
| | 208400 | 70 x 40 | 2 |



209000



209099

Pialletto e fermi per taglieri in polietilene

| Scraper and stoppers for polyethylene cutting boards | Cod. | Box |
|--|---------------|-----|
| | 209000 | |
| | 209099 | 6 |



Cod. 209099

| | | | | | |
|--------------------------------|--|-----------------------------------|---|---|----------------------|
| | | | | | |
| CARNI CRUDE RAW MEAT | PANE E FORMAGGI BREAD AND CHEESE | CARNI COTTE COOKED MEAT | INSALATA E FRUTTA VEGETABLES AND FRUITS | VERDURE COTTE COOKED VEGETABLES | PESCE FISH |



MAX. MM 146

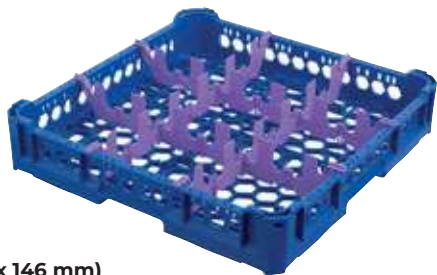
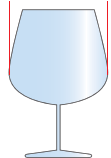

Cestello bicchieri a 9 scomparti (146 x 146 mm)

| Glass rack with 9 compartments (146 x 146 mm) | Cod. | L x W cm | H mm | Box |
|---|---------------|----------|---------|-----|
| | 210000 | 50 x 50 | < 65 | 2 |
| | 210001 | 50 x 50 | 66-120 | |
| | 210002 | 50 x 50 | 121-250 | |
| | 210003 | 50 x 50 | 251-340 | |



MAX. MM 88

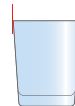

Cestello bicchieri a 25 scomparti (88 x 88 mm)

| Glass rack with 25 compartments (88 x 88 mm) | Cod. | L x W cm | H mm | Box |
|--|---------------|----------|---------|-----|
| | 210020 | 50 x 50 | < 65 | 2 |
| | 210021 | 50 x 50 | 66-120 | |
| | 210022 | 50 x 50 | 121-250 | |
| | 210023 | 50 x 50 | 251-340 | |



MAX. MM 113

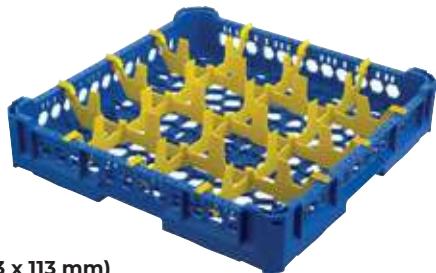
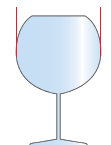

Cestello bicchieri a 16 scomparti (113 x 113 mm)

| Glass rack with 16 compartments (113 x 113 mm) | Cod. | L x W cm | H mm | Box |
|--|---------------|----------|---------|-----|
| | 210010 | 50 x 50 | < 65 | 2 |
| | 210011 | 50 x 50 | 66-120 | |
| | 210012 | 50 x 50 | 121-250 | |
| | 210013 | 50 x 50 | 251-340 | |



MAX. MM 73



Cestello bicchieri a 36 scomparti (73 x 73 mm)

| Glass rack with 36 compartments (73 x 73 mm) | Cod. | L x W cm | H mm | Box |
|--|---------------|----------|---------|-----|
| | 210030 | 50 x 50 | < 65 | 2 |
| | 210031 | 50 x 50 | 66-120 | |
| | 210032 | 50 x 50 | 121-250 | |
| | 210033 | 50 x 50 | 251-340 | |



PERSONALIZZAZIONE FACILE E VELOCE
QUICK AND EASY PERSONALISING

I cestelli bicchieri consentono una facile e veloce personalizzazione, adattandosi alle vostre esigenze di lavaggio. La presenza di elementi scorrevoli all'interno delle guide fissate ai quattro angoli permette di variare l'altezza totale del cestello.

Basta sollevare l'elemento superiore (l'estensione con la griglia a scomparti) fino all'altezza desiderata. (Fig.1)

Inserite i 4 bottoni di fissaggio in dotazione per bloccare i cursori di scorrimento e fissare l'estensione. (Fig. 2)

Il cestello è pronto per essere riempito con i bicchieri da mandare in lavaggio. (Fig. 3)

Se una volta ultimato il processo di lavaggio necessitate una diversa altezza del cestello non dovete fare altro che rimuovere (e sostituire) i bottoni di fissaggio, i cursori saranno nuovamente liberi di scorrere permettendovi una differente personalizzazione dell'altezza del cestello.



These glass racks can be quickly and easily personalised, letting you adapt to your specific needs each time. Special elements running inside the fixed guides at the four corners let you change the total height of your rack whenever necessary.

Simply lift the top element (extender with divider insert) to the height you want. (Fig.1)

Insert the 4 fixing buttons provided to stop the sliders and so fix the extender. (Fig. 2)

Your rack is ready to be filled with glasses to be washed. (Fig. 3)

If, after washing, you need to change the height for other glasses, simply remove (and replace) the buttons: the sliders are now freed for you to adjust the height (insert the buttons at the new height).

MAX. MM 63

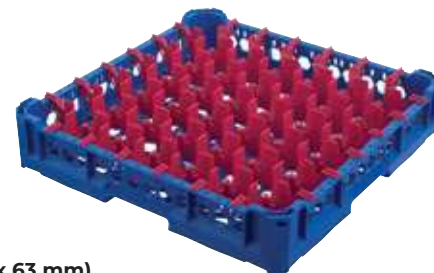
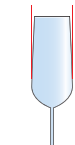

Cestello bicchieri a 49 scomparti (63 x 63 mm)

| Glass rack with 49 compartments (63 x 63 mm) | Cod. | L x W cm | H mm | Box |
|--|---------------|----------|---------|-----|
| | 210040 | 50 x 50 | < 65 | 2 |
| | 210041 | 50 x 50 | 66-120 | |
| | 210042 | 50 x 50 | 121-250 | |
| | 210043 | 50 x 50 | 251-340 | |



1

- CESTELLO BASE 50X50 CM CON GRIGLIA A 9-16-25-36-49 SCOMPARTI
- 50X50 CM RACK BASE AND DIVIDER INSERT WITH 9-16-25-36-49 COMPART

2

- CESTELLO BASE 50X50 CM CON GRIGLIA A 9-16-25-36-49 SCOMPARTI
- ESTENSIONE 50X50 CM CON GRIGLIA A 9-16-25-36-49 SCOMPARTI
- 50X50 CM RACK BASE AND DIVIDER INSERT WITH 9-16-25-36-49 COMPART
- 50X50 CM EXTENDER AND DIVIDER INSERT WITH 9-16-25-36-49 COMPART



Cestello tazze e terrine

Cup/pan rack Cod. L x W cm Box
 211000 50 x 50 2



Cestello vassoi aperto

Open tray rack Cod. L x W cm Box
 211003 50 x 50 2



Cestello piatti-vassoi

Plate/tray rack Cod. L x W cm Box
 211001 50 x 50 2



Cestello posate

Cutlery rack Cod. L x W cm Box
 211004 50 x 50 2



Cestello vassoi

Tray rack Cod. L x W cm Box
 211002 50 x 50 2



Carrello per cestelli

Rack trolley Cod. 219000



CONFEZIONE
 20
 PEZZI/PIECES

Bottoni fissaggio di ricambio

Spare fixing buttons Cod. 219900



UNICO CESTELLO, DIFFERENTI SOLUZIONI

SINGLE RACK, DIFFERENT SOLUTIONS

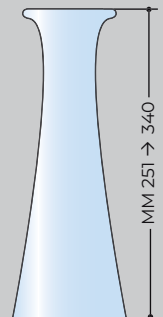
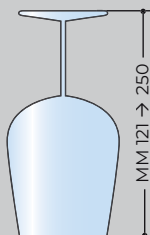
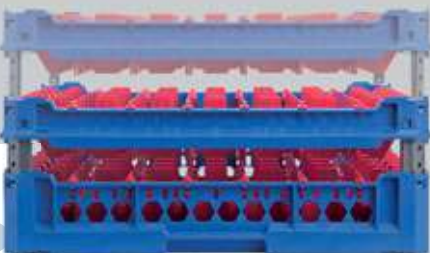

- CESTELLO BASE 50X50 CM CON GRIGLIA A 9-16-25-36-49 SCOMPARTI
- ESTENSIONE 50X50 CM CON GRIGLIA A 9-16-25-36-49 SCOMPARTI
- BOTTONI PER FISSAGGIO
- 50X50 CM RACK BASE AND DIVIDER INSERT WITH 9-16-25-36-49 COMPART
- 50X50 CM EXTENDER AND DIVIDER INSERT WITH 9-16-25-36-49 COMPART
- FIXING BUTTONS

- CESTELLO BASE 50X50 CM CON GRIGLIA A 9-16-25-36-49 SCOMPARTI
- ESTENSIONE 50X50 CM CON GRIGLIA A 9-16-25-36-49 SCOMPARTI
- ESTENSIONE APERTA 50X50 CM
- BOTTONI PER FISSAGGIO
- 50X50 CM RACK BASE AND DIVIDER INSERT WITH 9-16-25-36-49 COMPART
- 50X50 CM EXTENDER AND DIVIDER INSERT WITH 9-16-25-36-49 COMPART
- OPEN 50X50 CM EXTENDER
- FIXING BUTTONS

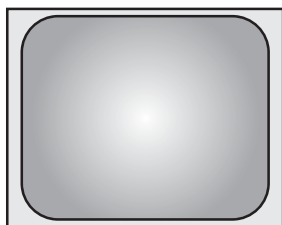

Bacinella GN 2/1 in acciaio inox

| Gastronorm container 2/1 in stainless steel | Cod. | L x W cm | H cm |
|---|---------------|----------|------|
| | 220002 | 65 x 53 | 2 |
| | 220004 | 65 x 53 | 4 |
| | 220006 | 65 x 53 | 6,5 |
| | 220010 | 65 x 53 | 10 |
| | 220015 | 65 x 53 | 15 |
| | 220020 | 65 x 53 | 20 |

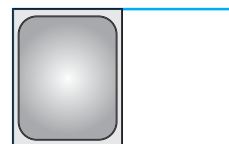

Bacinella GN 1/2 in acciaio inox

| Gastronorm container 1/2 in stainless steel | Cod. | L x W cm | H cm |
|---|---------------|-------------|------|
| | 220302 | 32,5 x 26,5 | 2 |
| | 220304 | 32,5 x 26,5 | 4 |
| | 220306 | 32,5 x 26,5 | 6,5 |
| | 220310 | 32,5 x 26,5 | 10 |
| | 220315 | 32,5 x 26,5 | 15 |
| | 220320 | 32,5 x 26,5 | 20 |



Bacinella GN 1/1 in acciaio inox

| Gastronorm container 1/1 in stainless steel | Cod. | L x W cm | H cm |
|---|---------------|-----------|------|
| | 220102 | 53 x 32,5 | 2 |
| | 220104 | 53 x 32,5 | 4 |
| | 220106 | 53 x 32,5 | 6,5 |
| | 220110 | 53 x 32,5 | 10 |
| | 220115 | 53 x 32,5 | 15 |
| | 220120 | 53 x 32,5 | 20 |



Bacinella GN 1/3 in acciaio inox

| Gastronorm container 1/3 in stainless steel | Cod. | L x W cm | H cm |
|---|---------------|-------------|------|
| | 220402 | 32,5 x 17,5 | 2 |
| | 220404 | 32,5 x 17,5 | 4 |
| | 220406 | 32,5 x 17,5 | 6,5 |
| | 220410 | 32,5 x 17,5 | 10 |
| | 220415 | 32,5 x 17,5 | 15 |
| | 220420 | 32,5 x 17,5 | 20 |

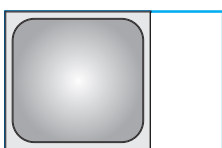

Bacinella GN 2/3 in acciaio inox

| Gastronorm container 2/3 in stainless steel | Cod. | L x W cm | H cm |
|---|---------------|-------------|------|
| | 220202 | 35,5 x 32,5 | 2 |
| | 220204 | 35,5 x 32,5 | 4 |
| | 220206 | 35,5 x 32,5 | 6,5 |
| | 220210 | 35,5 x 32,5 | 10 |
| | 220215 | 35,5 x 32,5 | 15 |
| | 220220 | 35,5 x 32,5 | 20 |

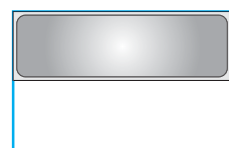

Bacinella GN 2/4 in acciaio inox

| Gastronorm container 2/4 in stainless steel | Cod. | L x W cm | H cm |
|---|---------------|-----------|------|
| | 222904 | 53 x 16,2 | 4 |
| | 222906 | 53 x 16,2 | 6,5 |
| | 222910 | 53 x 16,2 | 10 |
| | 222915 | 53 x 16,2 | 15 |



Bacinella GN 2/8 in acciaio inox

| Gastronorm container 2/8 in stainless steel | Cod. | L x W cm | H cm |
|---|---------------|-----------|------|
| | 224015 | 13 x 32,5 | 15 |

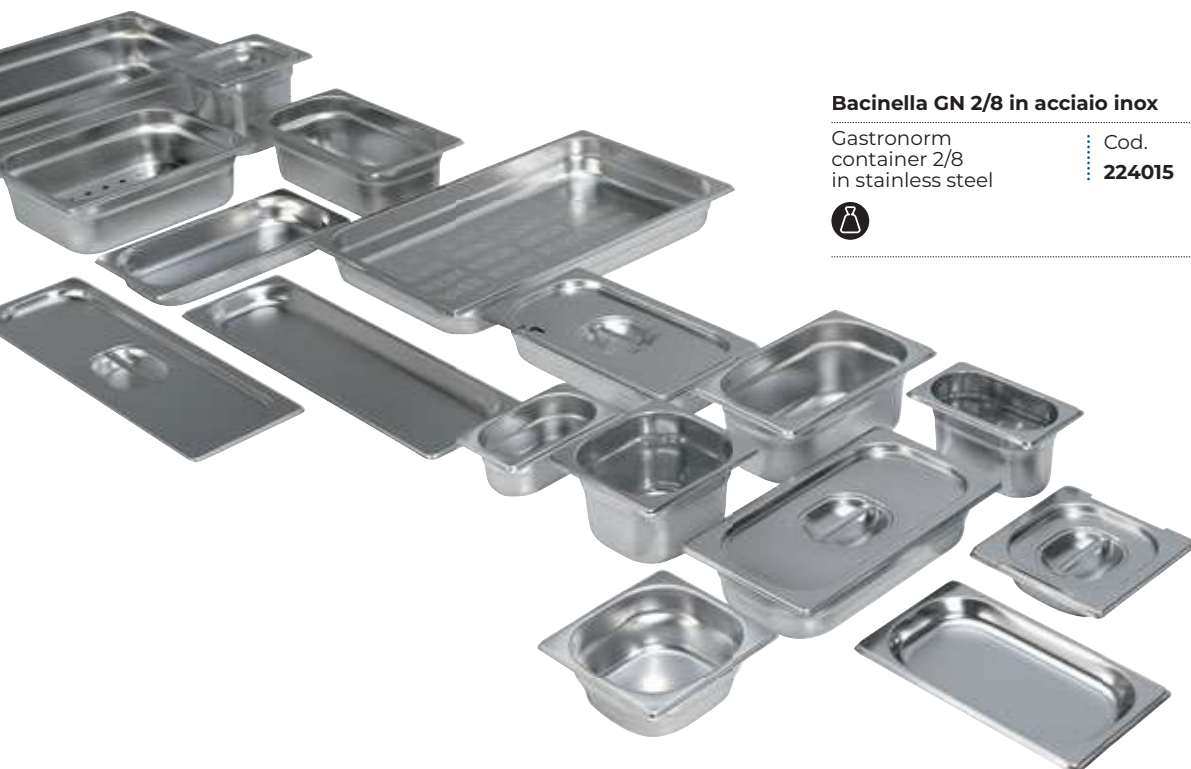



Bacinella GN 1/4 in acciaio inox

| Gastronorm container 1/4 in stainless steel | Cod. | L x W cm | H cm |
|---|---------------|-------------|------|
| | 220502 | 26,4 x 16,2 | 2 |
| | 220504 | 26,4 x 16,2 | 4 |
| | 220506 | 26,4 x 16,2 | 6,5 |
| | 220510 | 26,4 x 16,2 | 10 |
| | 220515 | 26,4 x 16,2 | 15 |
| | 220520 | 26,4 x 16,2 | 20 |



Bacinella GN 1/6 in acciaio inox

| Gastronorm container 1/6 in stainless steel | Cod. | L x W cm | H cm |
|---|---------------|-------------|------|
| | 220602 | 17,6 x 16,2 | 2 |
| | 220604 | 17,6 x 16,2 | 4 |
| | 220606 | 17,6 x 16,2 | 6,5 |
| | 220610 | 17,6 x 16,2 | 10 |
| | 220615 | 17,6 x 16,2 | 15 |
| | 220620 | 17,6 x 16,2 | 20 |



Bacinella GN 1/9 in acciaio inox

| Gastronorm container 1/9 in stainless steel | Cod. | L x W cm | H cm |
|---|---------------|-------------|------|
| | 220706 | 17,6 x 10,8 | 6,5 |
| | 220710 | 17,6 x 10,8 | 10 |



PREPARARE, CUOCERE, TRASPORTARE ED ESPORRE
PREPARE, COOK, TRANSPORT AND DISPLAY

Potete fare tutto utilizzando il medesimo contenitore evitando scomode sostituzioni.

La serie in acciaio inox 18/10 è adatta a qualunque tipo di preparazione sia a caldo che a freddo e le sue caratteristiche tecniche ne consentono l'uso in tutte le moderne apparecchiature professionali: friggitrice, forni di cottura, armadi frigoriferi ecc. Totalmente idonea al contatto con gli alimenti, secondo la normativa UE89/109, garantisce una perfetta igienicità grazie anche alla semplicità di pulizia (può andare in lavastoviglie).

You can do everything using the same container, avoiding bothersome replacements.

The series in 18/10 stainless steel is ideal for all kinds of hot and cold preparations and its technical features mean that the series can be used with all modern professional equipment: fryers, cooking ovens, refrigerated units etc. Fully suitable for contact with foodstuffs in accordance with UE89/109 Standards, it ensures perfect hygiene, thanks also to easy cleaning (it can go in the dishwasher).

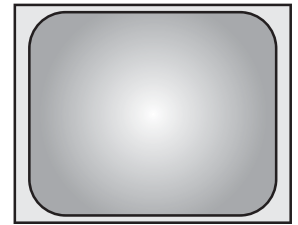

Teglia GN 2/1 in acciaio inox

| Gastronorm baking pan 2/1 in stainless steel | Cod. | L x W cm | H cm |
|--|---------------|----------|------|
| | 223002 | 65 x 53 | 2 |
| | 223004 | 65 x 53 | 4 |
| | 223006 | 65 x 53 | 6,5 |



Teglia GN 1/1 in acciaio inox

| Gastronorm baking pan 1/1 in stainless steel | Cod. | L x W cm | H cm |
|--|---------------|-----------|------|
| | 220802 | 53 x 32,5 | 2 |
| | 220804 | 53 x 32,5 | 4 |
| | 220806 | 53 x 32,5 | 6,5 |

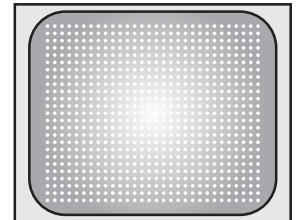

Bacinella forata GF 2/1 in acciaio inox

| Gastronorm perforated container 2/1 in stainless steel | Cod. | L x W cm | H cm |
|--|---------------|----------|------|
| | 220902 | 65 x 53 | 2 |
| | 220904 | 65 x 53 | 4 |
| | 220906 | 65 x 53 | 6,5 |
| | 220910 | 65 x 53 | 10 |
| | 220915 | 65 x 53 | 15 |
| | 220920 | 65 x 53 | 20 |

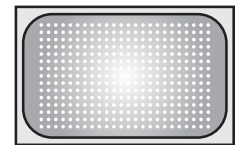

Bacinella forata GF 1/1 in acciaio inox

| Gastronorm perforated container 1/1 in stainless steel | Cod. | L x W cm | H cm |
|--|---------------|-----------|------|
| | 221002 | 53 x 32,5 | 2 |
| | 221004 | 53 x 32,5 | 4 |
| | 221006 | 53 x 32,5 | 6,5 |
| | 221010 | 53 x 32,5 | 10 |
| | 221015 | 53 x 32,5 | 15 |
| | 221020 | 53 x 32,5 | 20 |

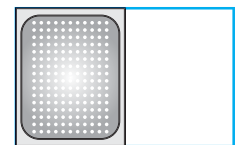

Bacinella forata GF 1/2 in acciaio inox

| Gastronorm perforated container 1/2 in stainless steel | Cod. | L x W cm | H cm |
|--|---------------|-------------|------|
| | 221102 | 32,5 x 26,5 | 2 |
| | 221104 | 32,5 x 26,5 | 4 |
| | 221106 | 32,5 x 26,5 | 6,5 |
| | 221110 | 32,5 x 26,5 | 10 |
| | 221115 | 32,5 x 26,5 | 15 |
| | 221120 | 32,5 x 26,5 | 20 |





Falso fondo forato

| Gastronorm drainer plate | Cod. | GN |
|--------------------------|---------------|-----|
| | 221611 | 1/1 |
| | 221612 | 1/2 |
| | 221621 | 2/1 |
| | 221623 | 2/3 |



Coppia maniglie cascanti

| Falling handles | Cod. |
|-----------------|---------------|
| | 221800 |



LA COPPIA MANIGLIE CASCANTI VIENE VENDUTA SOLTANTO IN COMBINAZIONE CON LA RELATIVA BACINELLA GASTRONORM. IL COSTO DELLE MANIGLIE È DA SOMMARSÌ AL COSTO DELLA BACINELLA.

TWO FALLING HANDLES ARE SOLD ONLY AS SET WITH THE CORRESPONDING GN FOODCONTAINER. HANDLE-PRICE HAS TO BE ADDED TO THE CONTAINER-PRICE.



Separatore

| Adaptor bar | Cod. | L cm |
|-------------|---------------|------|
| | 221726 | 26,5 |
| | 221732 | 32,5 |
| | 221753 | 53 |

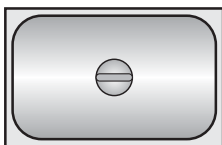

Coperchio in acciaio inox

| Lid in stainless steel | Cod. | GN |
|------------------------|---------------|-----|
| | 221911 | 1/1 |
| | 221912 | 1/2 |
| | 221913 | 1/3 |
| | 221914 | 1/4 |
| | 221916 | 1/6 |
| | 221919 | 1/9 |
| | 221923 | 2/3 |
| | 221924 | 2/4 |
| | 221928 | 2/8 |

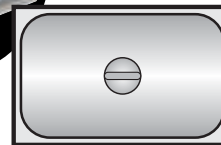

Coperchio in acciaio inox con guarnizione

| Lid in stainless steel with trimming | Cod. | GN |
|--------------------------------------|---------------|-----|
| | 222011 | 1/1 |
| | 222012 | 1/2 |
| | 222013 | 1/3 |
| | 222014 | 1/4 |
| | 222016 | 1/6 |
| | 222023 | 2/3 |

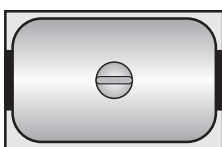

Coperchio in acciaio inox con spacco maniglie

| Lid in stainless steel with notch for handles | Cod. | GN |
|---|---------------|-----|
| | 222111 | 1/1 |
| | 222112 | 1/2 |
| | 222113 | 1/3 |
| | 222116 | 1/6 |
| | 222123 | 2/3 |

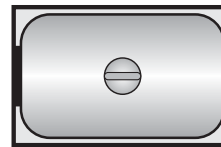

Coperchio in acciaio inox con spacco maniglie e guarnizione

| Lid in stainless steel with trimming and notch for handles | Cod. | GN |
|--|---------------|-----|
| | 222211 | 1/1 |
| | 222212 | 1/2 |

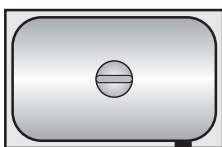

Coperchio in acciaio inox con spacco mestolo

| Lid in stainless steel with notch for ladle | Cod. | GN |
|---|---------------|-----|
| | 222313 | 1/3 |
| | 222314 | 1/4 |
| | 222316 | 1/6 |
| | 222323 | 2/3 |

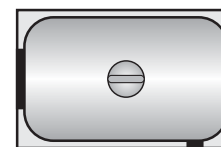

Coperchio in acciaio inox con spacco maniglie e mestolo

| Lid in stainless steel with notch for handles and ladle | Cod. | GN |
|---|---------------|-----|
| | 222411 | 1/1 |
| | 222412 | 1/2 |
| | 222413 | 1/3 |
| | 222423 | 2/3 |





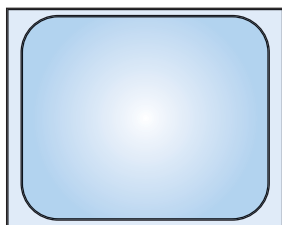

Bacinella GN 2/1 in plastica

| Gastronorm container 2/1 in plastic | Cod. | L x W cm | H cm |
|--|---------------|----------|------|
| | 225020 | 65 x 53 | 20 |

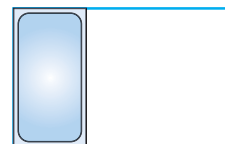

Bacinella GN 1/3 in plastica

| Gastronorm container 1/3 in plastic | Cod. | L x W cm | H cm |
|--|---------------|-------------|------|
| | 225406 | 32,5 x 17,5 | 6,5 |
| | 225410 | 32,5 x 17,5 | 10 |
| | 225415 | 32,5 x 17,5 | 15 |
| | 225420 | 32,5 x 17,5 | 20 |



Bacinella GN 1/1 in plastica

| Gastronorm container 1/1 in plastic | Cod. | L x W cm | H cm |
|--|---------------|-----------|------|
| | 225106 | 53 x 32,5 | 6,5 |
| | 225110 | 53 x 32,5 | 10 |
| | 225115 | 53 x 32,5 | 15 |
| | 225120 | 53 x 32,5 | 20 |

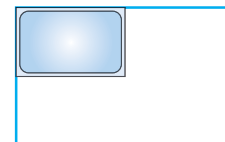

Bacinella GN 1/4 in plastica

| Gastronorm container 1/4 in plastic | Cod. | L x W cm | H cm |
|--|---------------|-------------|------|
| | 225506 | 26,4 x 16,2 | 6,5 |
| | 225510 | 26,4 x 16,2 | 10 |
| | 225515 | 26,4 x 16,2 | 15 |
| | 225520 | 26,4 x 16,2 | 20 |



Bacinella GN 1/2 in plastica

| Gastronorm container 1/2 in plastic | Cod. | L x W cm | H cm |
|--|---------------|-------------|------|
| | 225306 | 32,5 x 26,5 | 6,5 |
| | 225310 | 32,5 x 26,5 | 10 |
| | 225315 | 32,5 x 26,5 | 15 |
| | 225320 | 32,5 x 26,5 | 20 |



Bacinella GN 1/6 in plastica

| Gastronorm container 1/6 in plastic | Cod. | L x W cm | H cm |
|--|---------------|-------------|------|
| | 225606 | 17,6 x 16,2 | 6,5 |
| | 225610 | 17,6 x 16,2 | 10 |
| | 225615 | 17,6 x 16,2 | 15 |
| | 225620 | 17,6 x 16,2 | 20 |



Bacinella GN 1/9 in plastica

| Gastronorm container 1/9 in plastic | Cod. | L x W cm | H cm |
|--|---------------|-------------|------|
| | 225706 | 17,6 x 10,8 | 6,5 |
| | 225710 | 17,6 x 10,8 | 10 |

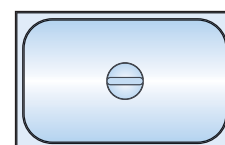

Coperchio in plastica

| Lid in plastic | Cod. | GN |
|----------------|---------------|-----|
| | 226010 | 2/1 |
| | 226011 | 1/1 |
| | 226012 | 1/2 |
| | 226013 | 1/3 |
| | 226014 | 1/4 |
| | 226016 | 1/6 |
| | 226019 | 1/9 |



Falso fondo forato in plastica

| Gastronorm drainer plate in plastic | Cod. | GN |
|--|---------------|-----|
| | 227010 | 2/1 |
| | 227011 | 1/1 |
| | 227012 | 1/2 |



Bacinella GN 1/1 in polipropilene



| Gastronorm container 1/1 in polypropylene | Cod. | L x W cm | H cm |
|---|---------------|-----------|------|
| | 228106 | 53 x 32,5 | 6,5 |
| | 228110 | 53 x 32,5 | 10 |
| | 228115 | 53 x 32,5 | 15 |
| | 228120 | 53 x 32,5 | 20 |



Bacinella GN 1/4 in polipropilene



| Gastronorm container 1/4 in polypropylene | Cod. | L x W cm | H cm |
|---|---------------|-------------|------|
| | 228506 | 26,4 x 16,2 | 6,5 |
| | 228510 | 26,4 x 16,2 | 10 |
| | 228515 | 26,4 x 16,2 | 15 |
| | 228520 | 26,4 x 16,2 | 20 |



Bacinella GN 1/2 in polipropilene

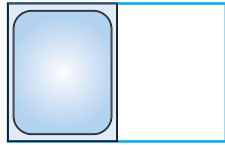

| Gastronorm container 1/2 in polypropylene | Cod. | L x W cm | H cm |
|---|---------------|-------------|------|
| | 228306 | 32,5 x 26,5 | 6,5 |
| | 228310 | 32,5 x 26,5 | 10 |
| | 228315 | 32,5 x 26,5 | 15 |
| | 228320 | 32,5 x 26,5 | 20 |



Bacinella GN 1/6 in polipropilene



| Gastronorm container 1/6 in polypropylene | Cod. | L x W cm | H cm |
|---|---------------|-------------|------|
| | 228606 | 17,6 x 16,2 | 6,5 |
| | 228610 | 17,6 x 16,2 | 10 |
| | 228615 | 17,6 x 16,2 | 15 |
| | 228620 | 17,6 x 16,2 | 20 |



Bacinella GN 1/3 in polipropilene



| Gastronorm container 1/3 in polypropylene | Cod. | L x W cm | H cm |
|---|---------------|-------------|------|
| | 228406 | 32,5 x 17,5 | 6,5 |
| | 228410 | 32,5 x 17,5 | 10 |
| | 228415 | 32,5 x 17,5 | 15 |
| | 228420 | 32,5 x 17,5 | 20 |



Bacinella GN 1/9 in polipropilene



| Gastronorm container 1/9 in polypropylene | Cod. | L x W cm | H cm |
|---|---------------|-------------|------|
| | 228706 | 17,6 x 10,8 | 6,5 |
| | 228710 | 17,6 x 10,8 | 10 |



Coperchio in polipropilene

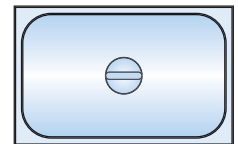

| Lid in polypropylene | Cod. | GN |
|----------------------|---------------|-----|
| | 229011 | 1/1 |
| | 229012 | 1/2 |
| | 229013 | 1/3 |
| | 229014 | 1/4 |
| | 229016 | 1/6 |
| | 229019 | 1/9 |



Falso fondo forato in polipropilene



| Gastronorm drainer plate in polypropylene | Cod. | GN |
|---|---------------|-----|
| | 229211 | 1/1 |
| | 229212 | 1/2 |
| | 229213 | 1/3 |





PIZZERIA

LINEA DESIGN

DESIGN LINE

88

LINEA TRADIZIONE

TRADITION LINE

98

LINEA GLUTEN FREE

GLUTEN FREE LINE

100

LINEA BLUE DROP

BLUE DROP LINE

102

ACCESSORI PIZZERIA

PIZZERIA ACCESSORIES

104

SPATOLE, PALETTE E ROTELLE PIZZA

SPATULAS, TURNERS AND PIZZA WHEEL CUTTERS

109

LA NOSTRA LINEA DI PRODOTTI DEDICATA ALLA PIZZERIA SI AMPLIA CON NUOVI ARTICOLI STUDIATI PER MIGLIORARE OGNI FASE DEL VOSTRO LAVORO. ATTREZZATURE PROFESSIONALI E SOLUZIONI INNOVATIVE PENSATE PER OFFRIRE EFFICIENZA, QUALITÀ E PRATICITÀ. SCOPRITE LE NOSTRE NOVITÀ E PORTATE LA VOSTRA PIZZERIA A UN LIVELLO SUPERIORE!

OUR PIZZERIA ASSORTMENT IS EXPANDING WITH NEW ITEMS DESIGNED TO IMPROVE EVERY STAGE OF YOUR WORK. PROFESSIONAL EQUIPMENT AND INNOVATIVE SOLUTIONS CREATED TO OFFER EFFICIENCY, QUALITY, AND PRACTICALITY. DISCOVER OUR NEW PRODUCTS AND TAKE YOUR PIZZERIA TO THE NEXT LEVEL!



LINEA DESIGN DESIGN LINE

UNA GAMMA AMPIA IN CUI LA BELLEZZA DELLE FORME SPOSA L'ECCELLENZA NELLE PRESTAZIONI

A WIDE RANGE WHERE THE BEAUTY OF FORM MARRIES EXCELLENCE IN PERFORMANCE



LINEA TRADIZIONE TRADITION LINE

LA CLASSICITÀ REINTERPRETATA, RINNOVATA E AGGIORNATA PER RESTARE SEMPRE AL PASSO CON I TEMPI

CLASSIC STYLE REINTERPRETED, RENEWED AND UPDATED TO ALWAYS BE IN STEP WITH THE TIMES



LINEA GLUTEN FREE GLUTEN FREE LINE

RICONOSCIBILE A COLPO D'OCCHIO PER UN'ATTENZIONE SPECIALE VERSO I PROPRI CLIENTI

RECOGNISABLE AT A GLANCE FOR A SPECIAL ATTENTION TO YOUR CUSTOMERS



NEW

LINEA BLUE DROP BLUE DROP LINE

UNA MANEGGEVOLEZZA SENZA PARI GRAZIE ALLA PERFETTA UNIONE DI ROBUSTEZZA E LEGGEREZZA

UNPARALLELED PRACTICALITY THANKS TO THE PERFECT COMBINATION OF STRENGTH AND LIGHTNESS

COLLEZIONE PUNTOROSSO



UNA COLLEZIONE PROGETTATA, SVILUPPATA E TESTATA CURANDO OGNI SINGOLO MINIMO DETTAGLIO

- I LATI PALA SMUSSATI RENDONO L'INVITO PIÙ AMPIO E AGEVOLE **1**
- LA SPECIALE NERVATURA POSTERIORE DI RINFORZO GARANTISCE LEGGEREZZA E RESISTENZA AL CALORE
- L'ANIMA INTERNA, INSERITA NELLA PARTE POSTERIORE CAVA DELLA PALA È SOLIDALE CON ESSA E IL MANICO, ENFATIZZA LA ROBUSTEZZA E ASSICURA MASSIMA IGIENE **2**
- IL POMOLO TONDO TERMINALE, RIGIDO INTERNAMENTE E MORBIDO ALL'ESTERNO, (NELLE LINEE DESIGN E GLUTEN FREE), HA FUNZIONE ANTIRUMORE E ANTINFORTUNISTICA
- IL PARTICOLARE DESIGN DELLE FORATURE ALLEGGERISCE PALE E PALETTINI SENZA INTACCARNE LA RIGIDITÀ **3**
- I 3 RIVETTI DI FISSAGGIO (IN LINEA SULLA PALA E A TRIANGOLO SUI PALETTINI) SONO GARANZIA DI SOLIDITÀ **4**

A COLLECTION DESIGNED, DEVELOPED AND TESTED TAKING CARE OF EVERY SINGLE DETAIL

- THE BEVELED PEEL SIDES MAKE THE INVITATION WIDER AND EASIER **1**
- THE SPECIAL REINFORCEMENT RIB ON THE BACK GUARANTEES LIGHTNESS AND HEAT RESISTANCE
- THE INTERNAL CORE IS INSERTED IN THE BACK HOLLOW OF THE PIZZA PEEL AND IS INTEGRAL PART OF IT AND THE HANDLE, EMPHASIZING ROBUSTNESS AND ENSURING MAXIMUM HYGIENE **2**
- TERMINAL ROUND KNOB, RIGID ON THE INSIDE AND SOFT ON THE OUTSIDE, (IN THE DESIGN AND GLUTEN FREE LINES), HAS AN ANTI-NOISE AND ACCIDENT PREVENTION FUNCTION
- THE PARTICULAR DESIGN OF THE DRILLING LIGHTENS PEELS AND TURNING PEELS WITHOUT AFFECTING THEIR RIGIDITY **3**
- THE 3 FASTENING RIVETS (IN LINE ON THE PEELS AND IN A TRIANGLE SHAPE ON THE TURNING PEELS) ARE A GUARANTEE OF SOLIDITY **4**

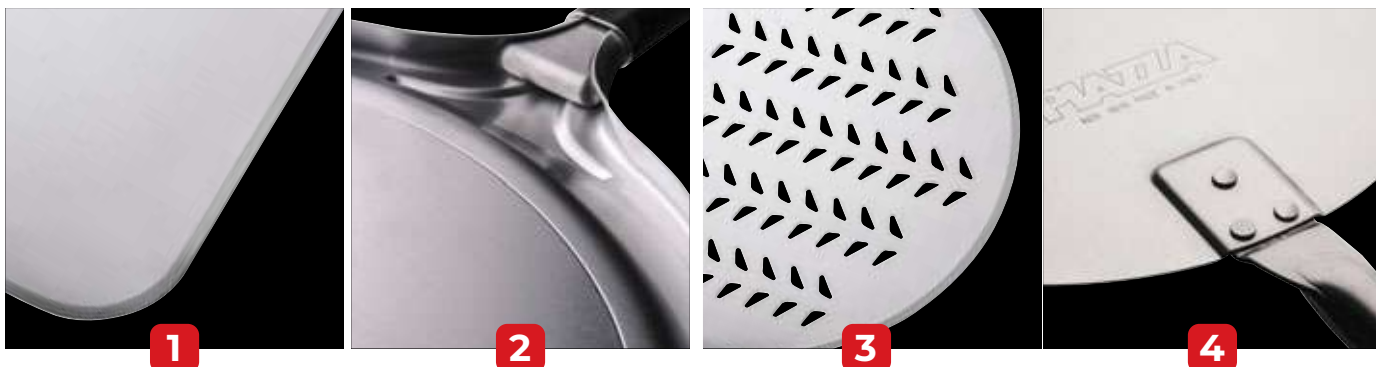

LA PALA OFFRE LA MASSIMA SUPERFICIE DISPONIBILE PER INFORNARE SENZA L'INTRALCIO DELLE NERVATURE. LO SMUSSO SU TRE LATI NE ENFATIZZA PRATICITÀ ED EFFICIENZA

THE DESIGN OF THE PIZZA PEEL OFFERS THE MAXIMUM AVAILABLE SURFACE TO PLACE IN THE OVEN WITHOUT OBSTACLES. THE BEVEL ON THE THREE SIDES EMPHASIZES EASE AND EFFICIENCY



ELASTOMERO MORBIDO ESTERNO
ANTIRUMORE E ANTINFORTUNIO
EXTERNAL SOFT ELASTOMER
SAFE AND NOISE REDUCTION

POLIMERO PLASTICO RIGIDO INTERNO
INNER RIGID PLASTIC POLYMER

LINEA DESIGN DESIGN LINE

LA LINEA DESIGN, SVILUPPATA ASSIEME AI PROFESSIONISTI DEL SETTORE E PROGETTATA FIN NEI MINIMI PARTICOLARI PER OFFRIRE UN'AMPIA GAMMA DI PRODOTTI E GARANTIRE PRESTAZIONI D'ECCELLENZA IN OGNI SITUAZIONE D'UTILIZZO. UNA COMBINAZIONE UNICA DI BELLEZZA ED EFFICIENZA.

THE DESIGN LINE, DEVELOPED WITH PIZZERIA PROFESSIONALS AND DESIGNED DOWN TO THE FINEST DETAILS TO OFFER A WIDE RANGE OF PRODUCTS AND GUARANTEE EXCELLENT PERFORMANCE IN EVERY SITUATION OF USE. A UNIQUE COMBINATION OF BEAUTY AND EFFICIENCY.



Pala pizza rettangolare in alluminio

Rectangular aluminum pizza peel

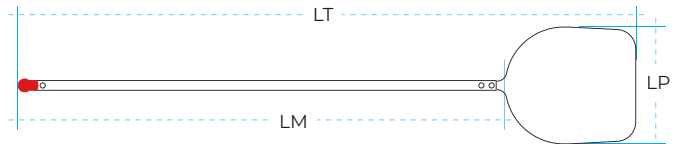

| LP 30 cm | | | LP 33 cm | | | LP 36 cm | | | LP 40 cm | | | LP 45 cm | | | LP 50 cm | | |
|----------|-----|-----|----------|-----|-----|----------|-----|-----|----------|-----|-----|----------|-----|-----|----------|-----|-----|
| Cod. | LM | LT | Cod. | LM | LT | Cod. | LM | LT | Cod. | LM | LT | Cod. | LM | LT | Cod. | LM | LT |
| 235002 | 60 | 94 | 235012 | 60 | 97 | 235022 | 60 | 100 | 235032 | 60 | 104 | 235042 | 60 | 110 | 235052 | 60 | 115 |
| 235004 | 120 | 154 | 235014 | 120 | 157 | 235024 | 120 | 160 | 235034 | 120 | 164 | 235044 | 120 | 170 | 235054 | 120 | 175 |
| 235006 | 150 | 184 | 235016 | 150 | 187 | 235026 | 150 | 190 | 235036 | 150 | 194 | 235046 | 150 | 200 | 235056 | 150 | 205 |
| 235008 | 180 | 212 | 235018 | 180 | 217 | 235028 | 180 | 220 | 235038 | 180 | 224 | 235048 | 180 | 230 | 235058 | 180 | 235 |
| | | | 235019 | 200 | 237 | 235029 | 200 | 240 | | | | | | | | | |



Pala pizza rettangolare forata in alluminio

Rectangular perforated aluminum pizza peel

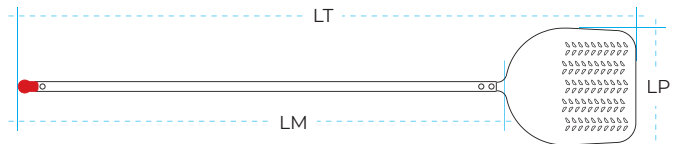

| LP 30 cm | | | LP 33 cm | | | LP 36 cm | | | LP 40 cm | | | LP 45 cm | | | LP 50 cm | | |
|----------|-----|-----|----------|-----|-----|----------|-----|-----|----------|-----|-----|----------|-----|-----|----------|-----|-----|
| Cod. | LM | LT | Cod. | LM | LT | Cod. | LM | LT | Cod. | LM | LT | Cod. | LM | LT | Cod. | LM | LT |
| 235102 | 60 | 94 | 235112 | 60 | 97 | 235122 | 60 | 100 | 235132 | 60 | 104 | 235142 | 60 | 110 | 235152 | 60 | 115 |
| 235104 | 120 | 154 | 235114 | 120 | 157 | 235124 | 120 | 160 | 235134 | 120 | 164 | 235144 | 120 | 170 | 235154 | 120 | 175 |
| 235106 | 150 | 184 | 235115 | 130 | 167 | 235125 | 130 | 170 | 235135 | 130 | 174 | 235146 | 150 | 200 | 235156 | 150 | 205 |
| 235108 | 180 | 214 | 235116 | 150 | 187 | 235126 | 150 | 190 | 235136 | 150 | 194 | 235148 | 180 | 230 | 235158 | 180 | 235 |
| | | | 235118 | 180 | 217 | 235128 | 180 | 220 | 235138 | 180 | 224 | | | | | | |
| | | | 235119 | 200 | 237 | 235129 | 200 | 240 | | | | | | | | | |



LIBERI DI SCEGLIERE LA PALA PIÙ ADATTA A VOI
FREE TO CHOOSE THE MOST SUITABLE PIZZA PEEL FOR YOU

6 DIFFERENTI MISURE
DIFFERENT SIZES

2 TIPOLOGIE (LISCIA E FORATA)
TYPES (PLAIN & PERFORATED)

6 LUNGHEZZE DI MANICO
HANDLE LENGTH

PIZZERIA - LINEA DESIGN PIZZERIA - DESIGN LINE



Pala pizza tonda in alluminio

Round aluminum pizza peel

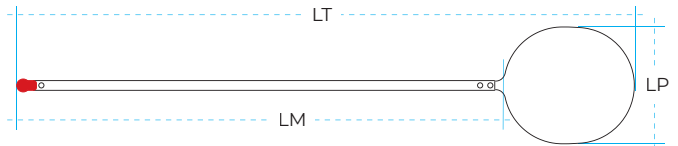

| LP 30 cm | | | LP 33 cm | | | LP 36 cm | | | LP 40 cm | | | LP 45 cm | | | LP 50 cm | | |
|----------|-----|-----|----------|-----|-----|----------|-----|-----|----------|-----|-----|----------|-----|-----|----------|-----|-----|
| Cod. | LM | LT | Cod. | LM | LT | Cod. | LM | LT | Cod. | LM | LT | Cod. | LM | LT | Cod. | LM | LT |
| 235202 | 60 | 94 | 235212 | 60 | 97 | 235222 | 60 | 100 | 235232 | 60 | 104 | 235242 | 60 | 110 | 235252 | 60 | 115 |
| 235204 | 120 | 154 | 235214 | 120 | 157 | 235224 | 120 | 160 | 235234 | 120 | 164 | 235244 | 120 | 170 | 235254 | 120 | 175 |
| 235206 | 150 | 184 | 235216 | 150 | 187 | 235226 | 150 | 190 | 235236 | 150 | 194 | 235246 | 150 | 200 | 235256 | 150 | 205 |
| 235208 | 180 | 214 | 235218 | 180 | 217 | 235228 | 180 | 220 | 235238 | 180 | 224 | 235248 | 180 | 230 | 235258 | 180 | 235 |
| | | | 235219 | 200 | 237 | 235229 | 200 | 240 | | | | | | | | | |



Pala pizza tonda forata in alluminio

Round perforated aluminum pizza peel

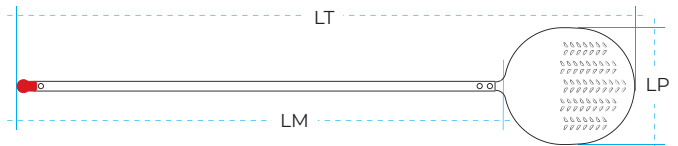

| LP 30 cm | | | LP 33 cm | | | LP 36 cm | | | LP 40 cm | | | LP 45 cm | | | LP 50 cm | | |
|----------|-----|-----|----------|-----|-----|----------|-----|-----|----------|-----|-----|----------|-----|-----|----------|-----|-----|
| Cod. | LM | LT | Cod. | LM | LT | Cod. | LM | LT | Cod. | LM | LT | Cod. | LM | LT | Cod. | LM | LT |
| 235302 | 60 | 94 | 235312 | 60 | 97 | 235322 | 60 | 100 | 235332 | 60 | 104 | 235342 | 60 | 110 | 235352 | 60 | 115 |
| 235304 | 120 | 154 | 235314 | 120 | 157 | 235324 | 120 | 160 | 235334 | 120 | 164 | 235344 | 120 | 170 | 235354 | 120 | 175 |
| 235306 | 150 | 184 | 235316 | 150 | 187 | 235326 | 150 | 190 | 235336 | 150 | 194 | 235346 | 150 | 200 | 235356 | 150 | 205 |
| 235308 | 180 | 214 | 235318 | 180 | 217 | 235328 | 180 | 220 | 235338 | 180 | 224 | 235348 | 180 | 230 | 235358 | 180 | 235 |
| | | | 235319 | 200 | 237 | 235329 | 200 | 240 | | | | | | | | | |



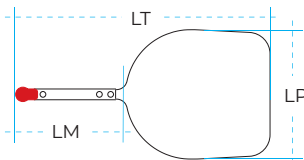

**Pala pizza rettangolare in alluminio
Manico corto**

Rectangular aluminum pizza peel - Short handle

| LP 30 cm | | | LP 33 cm | | | LP 36 cm | | | LP 40 cm | | | LP 45 cm | | | LP 50 cm | | |
|----------|----|----|----------|----|----|----------|----|----|----------|----|----|----------|----|----|----------|----|----|
| Cod. | LM | LT | Cod. | LM | LT | Cod. | LM | LT | Cod. | LM | LT | Cod. | LM | LT | Cod. | LM | LT |
| 235000 | 30 | 64 | 235010 | 30 | 67 | 235020 | 30 | 70 | 235030 | 30 | 74 | 235040 | 30 | 80 | 235050 | 30 | 85 |

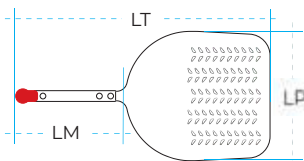

**Pala pizza rettangolare
forata in alluminio
Manico corto**

Rectangular perfor. aluminum pizza peel - Short handle

| LP 30 cm | | | LP 33 cm | | | LP 36 cm | | | LP 40 cm | | | LP 45 cm | | | LP 50 cm | | |
|----------|----|----|----------|----|----|----------|----|----|----------|----|----|----------|----|----|----------|----|----|
| Cod. | LM | LT | Cod. | LM | LT | Cod. | LM | LT | Cod. | LM | LT | Cod. | LM | LT | Cod. | LM | LT |
| 235100 | 30 | 64 | 235110 | 30 | 67 | 235120 | 30 | 70 | 235130 | 30 | 74 | 235140 | 30 | 80 | 235150 | 30 | 85 |

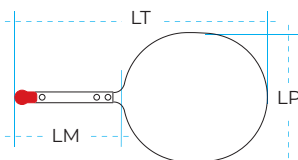

**Pala pizza tonda in alluminio
Manico corto**

Round aluminum pizza peel - Short handle

| LP 30 cm | | | LP 33 cm | | | LP 36 cm | | | LP 40 cm | | | LP 45 cm | | | LP 50 cm | | |
|----------|----|----|----------|----|----|----------|----|----|----------|----|----|----------|----|----|----------|----|----|
| Cod. | LM | LT | Cod. | LM | LT | Cod. | LM | LT | Cod. | LM | LT | Cod. | LM | LT | Cod. | LM | LT |
| 235200 | 30 | 64 | 235210 | 30 | 67 | 235220 | 30 | 70 | 235230 | 30 | 74 | 235240 | 30 | 80 | 235250 | 30 | 85 |

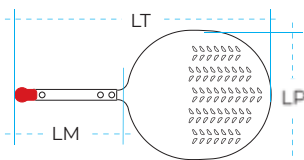

**Pala pizza tonda
forata in alluminio
Manico corto**

Round perfor. aluminum pizza peel - Short handle

| LP 30 cm | | | LP 33 cm | | | LP 36 cm | | | LP 40 cm | | | LP 45 cm | | | LP 50 cm | | |
|----------|----|----|----------|----|----|----------|----|----|----------|----|----|----------|----|----|----------|----|----|
| Cod. | LM | LT | Cod. | LM | LT | Cod. | LM | LT | Cod. | LM | LT | Cod. | LM | LT | Cod. | LM | LT |
| 235300 | 30 | 64 | 235310 | 30 | 67 | 235320 | 30 | 70 | 235330 | 30 | 74 | 235340 | 30 | 80 | 235350 | 30 | 85 |



I PALETTINI PIZZA, PAROLE D'ORDINE: EFFICIENZA E PRATICITÀ
 PIZZA TURNING PEELS, PASSWORDS: EFFICIENCY AND PRACTICALITY

5 LUNGHEZZE DI MANICO, 4 DIFFERENTI MISURE E 2 TIPOLOGIE DI PALETTINO (LISCIO E FORATO)
 5 HANDLE LENGTH, 4 DIFFERENT SIZES AND 2 TYPES OF PIZZA TURNING PEELS (PLAIN AND PERFORATED)

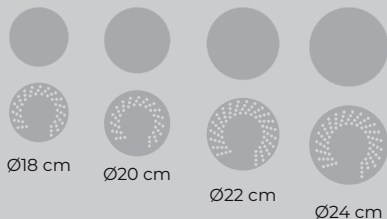

L'ERGONOMICA IMPUGNATURA POSTERIORE È REALIZZATA IN POLIMERO PLASTICO AD ALTA DENSITÀ, CONIUGA LA RESISTENZA AGLI URTI CON L'ISOLAMENTO DELLE MANI DAL CALORE. LA PARTE FISSA POSTERIORE È FISSATA AL MANICO CON UN RIVETTO IN ACCIAIO. LA PARTE MOBILE SCORRE SUL MANICO DAL FERMO ALLA PARTE FISSA, NELLA QUALE, A RIPOSO, SI INCASTRA E SI BLOCCA

THE ERGONOMIC PIZZA TURNING PEEL GRIP IS MADE OF HIGH-DENSITY PLASTIC POLYMER, IT COMBINES IMPACT RESISTANCE WITH PERFECT INSULATION OF THE HANDS FROM HEAT. THE REAR FIXED PART IS FIXED TO THE HANDLE WITH A STEEL RIVET. THE MOBILE PART SLIDES ON THE HANDLE FROM THE STOP TO THE FIXED PART, WHERE, AT REST, IT FITS AND LOCKS



LO SPECIALE DESIGN DEI FORI, PERIMETRALE E A RAGGIERA, EVITA LA FORATURA NELLA PARTE CENTRALE DEL PALETTINO, GARANTENDO UNA PERFETTA RIGIDITÀ

THE SPECIAL DESIGN OF THE HOLES, PERIMETER AND RADIAL, AVOIDS DRILLING IN THE CENTRAL PART OF THE PIZZA TURNING PEEL, GUARANTEEING PERFECT RIGIDITY WITH A REDUCED THICKNESS

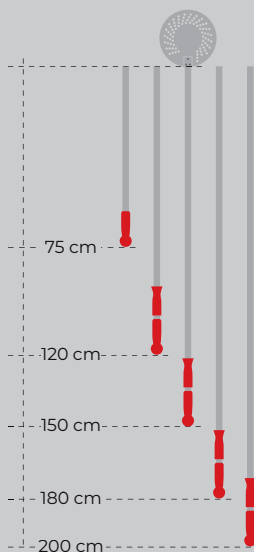

Palettino in inox

Stainless steel pizza turning peel

| LP Ø18 cm | | | LP Ø20 cm | | | LP Ø22 cm | | | LP Ø24 cm | | |
|-----------|-----|-----|-----------|-----|-----|-----------|-----|-----|-----------|-----|-----|
| Cod. | LM | LT | Cod. | LM | LT | Cod. | LM | LT | Cod. | LM | LT |
| 236002* | 75 | 93 | 236012* | 75 | 95 | 236022* | 75 | 97 | 236032* | 75 | 99 |
| 236004 | 120 | 138 | 236014 | 120 | 140 | 236024 | 120 | 142 | 236034 | 120 | 144 |
| 236006 | 150 | 168 | 236016 | 150 | 170 | 236026 | 150 | 172 | 236036 | 150 | 174 |
| 236008 | 180 | 198 | 236018 | 180 | 200 | 236028 | 180 | 202 | 236038 | 180 | 204 |
| 236009 | 200 | 218 | 236019 | 200 | 220 | 236029 | 200 | 222 | 236039 | 200 | 224 |

* NEI MODELLI CON MANICO DA 75 CM L'IMPUGNATURA HA SOLO LA PARTE FISSA POSTERIORE
 IN MODELS WITH A 75 CM HANDLE, THE GRIP ONLY HAS THE REAR FIXED PART

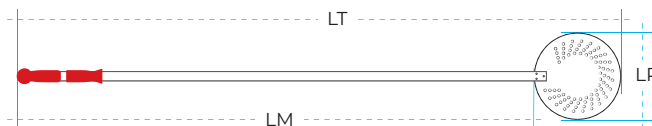

Palettino in inox forato

Perforated stainless steel pizza turning peel

| LP Ø18 cm | | | LP Ø20 cm | | | LP Ø22 cm | | | LP Ø24 cm | | |
|-----------|-----|-----|-----------|-----|-----|-----------|-----|-----|-----------|-----|-----|
| Cod. | LM | LT | Cod. | LM | LT | Cod. | LM | LT | Cod. | LM | LT |
| 236102* | 75 | 93 | 236112* | 75 | 95 | 236122* | 75 | 97 | 236132* | 75 | 99 |
| 236104 | 120 | 138 | 236114 | 120 | 140 | 236124 | 120 | 142 | 236134 | 120 | 144 |
| 236106 | 150 | 168 | 236116 | 150 | 170 | 236126 | 150 | 172 | 236136 | 150 | 174 |
| 236108 | 180 | 198 | 236118 | 180 | 200 | 236128 | 180 | 202 | 236138 | 180 | 204 |
| 236109 | 200 | 218 | 236119 | 200 | 220 | 236129 | 200 | 222 | 236139 | 200 | 224 |

* NEI MODELLI CON MANICO DA 75 CM L'IMPUGNATURA HA SOLO LA PARTE FISSA POSTERIORE
 IN MODELS WITH A 75 CM HANDLE, THE GRIP ONLY HAS THE REAR FIXED PART







**Pala pizza
"Alla Romana" in alluminio**

| Aluminum 'Roman style' pizza peel | Cod. | LP cm | LM cm | LT cm |
|-----------------------------------|---------------|-------|-------|-------|
| | 235400 | 23x40 | 30 | 77 |
| | 235402 | 23x40 | 60 | 107 |
| | 235404 | 23x40 | 120 | 167 |

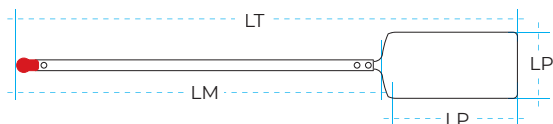

**Pala pizza forata
"Alla Romana" in alluminio**

| Perforated aluminum 'Roman style' pizza peel | Cod. | LP cm | LM cm | LT cm |
|--|---------------|-------|-------|-------|
| | 235500 | 23x40 | 30 | 77 |
| | 235502 | 23x40 | 60 | 107 |
| | 235504 | 23x40 | 120 | 167 |

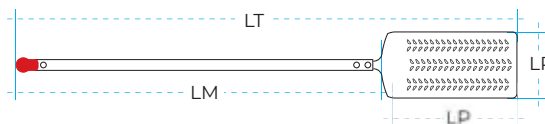

**Asse per pizza
"Alla Romana" in alluminio**

| Aluminum 'Roman style' pizza board | Cod. | LP cm |
|------------------------------------|---------------|-------|
| | 235802 | 25x50 |

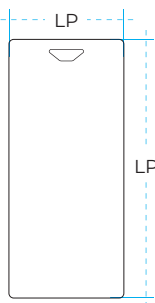

**Asse forato per pizza
"Alla Romana" in alluminio**

| Perforated aluminum 'Roman style' pizza board | Cod. | LP cm |
|---|---------------|-------|
| | 235842 | 25x50 |

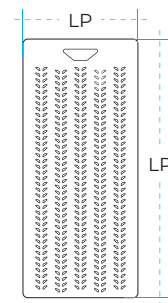

**Asse per pizza
"A Metro" in alluminio**

| Aluminum 'Pizza by the Metre' board | Cod. | LP cm |
|-------------------------------------|---------------|--------|
| | 235812 | 30x70 |
| | 235814 | 30x90 |
| | 235822 | 40x70 |
| | 235824 | 40x90 |
| | 235826 | 40x110 |

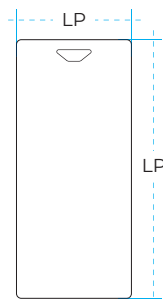

**Asse forato per pizza
"A Metro" in alluminio**

| Perforated aluminum 'Pizza by the Metre' board | Cod. | LP cm |
|--|---------------|--------|
| | 235852 | 30x70 |
| | 235854 | 30x90 |
| | 235862 | 40x70 |
| | 235864 | 40x90 |
| | 235866 | 40x110 |

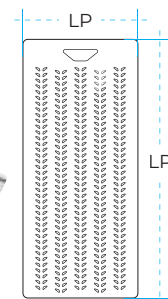

SPESSORE ASSI 2 mm
BOARDS THICKNESS

LA PULIZIA FORNO: UNA QUESTIONE DI QUALITÀ
OVEN CLEANING: A MATTER OF QUALITY

La pulizia del forno è fondamentale per garantire qualità, sicurezza e continuità del lavoro. Un forno ben mantenuto assicura una cottura uniforme delle pizze, evitando residui bruciati che potrebbero alterarne il sapore. Inoltre, rimuovere regolarmente cenere, grassi e incrostazioni riduce il rischio di fumo e cattivi odori, preservando un ambiente di lavoro più salubre. Una corretta manutenzione inoltre previene anche guasti e prolunga la vita dell'attrezzatura.

Cleaning the oven is essential to ensure quality, safety, and continuity of work. A well-maintained oven guarantees even cooking of the pizzas, preventing burnt residues that could affect their flavor. Additionally, regularly removing ash, grease, and buildup reduces the risk of smoke and unpleasant odors, helping maintain a healthier work environment. Proper maintenance also prevents malfunctions and extends the lifespan of the equipment.

SPAZZOLE SETOLE OTTONE
BRUSHES BRASS BRISTLE

20x6 H 7 cm

27x6,5 H 7 cm

Ø17x14 H 7 cm

SPAZZOLE SETOLE NATURALI
BRUSHES NATURAL BRISTLE

20x6 H 7 cm

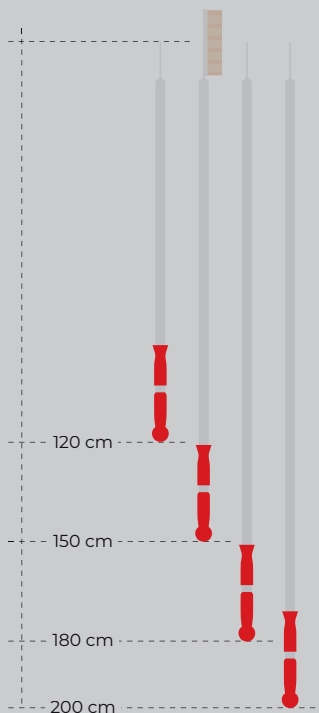

MANICO IN ACCIAIO INOX TONDO PERFETTAMENTE BILANCIATO CON DIAMETRO 18 MM E SPESSORE DI 1 MM
ROUND HANDLE IN STAINLESS STEEL PERFECTLY BALANCED WITH 18 MM DIAMETER AND THICKNESS OF 1 MM

L'IMPUGNATURA REALIZZATA CON DUE MATERIALI: RIGIDO ALL'INTERNO E MORBIDO ALL'ESTERNO, CARATTERIZZA, FUNZIONALMENTE ED ESTETICAMENTE, TUTTA LA LINEA PIZZERIA, MENTRE IL POMOLO TERMINALE HA UNA FUNZIONE ANTIRUMORE ED IL SUO DESIGN ATTUTISCE GLI URTI IN CASO DI CONTATTO

THE HANDLE MADE OF TWO MATERIALS: RIGID INSIDE AND SOFT ON THE OUTSIDE, IT CHARACTERIZES, FUNCTIONALLY AND AESTHETICALLY, THE ENTIRE PIZZERIA LINE, WHILE THE TERMINAL KNOB HAS A FUNCTION ANTI-NOISE AND ITS DESIGN ABSORBS SHOCKS IN CASE OF CONTACT.

4 MISURE DI MANICI, 4 MISURE DI SPAZZOLA, 2 TIPOLOGIE

4 HANDLE SIZES, 4 BRUSH SIZES, 2 TYPES



Spazzolone forno orientabile rettangolare - Setole ottone

Rectangular rotatable oven brush with brass bristle

LS 20x6 H 7 cm

LS 27x6,5 H 7 cm

| Cod. | LM | LT |
|---------------|-----|-----|
| 237004 | 120 | 133 |
| 237006 | 150 | 163 |
| 237008 | 180 | 193 |
| 237009 | 200 | 213 |

| Cod. | LM | LT |
|---------------|-----|-----|
| 237104 | 120 | 137 |
| 237106 | 150 | 167 |
| 237108 | 180 | 197 |
| 237109 | 200 | 217 |

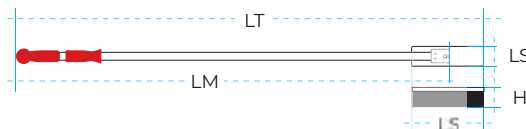

Spazzolone forno orientabile rettangolare - Setole naturali

Rectangular rotatable oven brush with natural bristle

LS 20x6 H 7 cm

| Cod. | LM | LT |
|---------------|-----|-----|
| 237014 | 120 | 133 |
| 237016 | 150 | 163 |
| 237018 | 180 | 193 |
| 237019 | 200 | 213 |

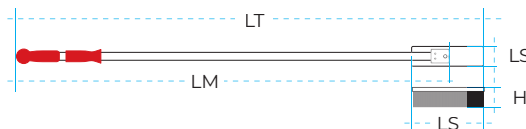

Spazzolone forno orientabile tondo - Setole ottone

Round rotatable oven brush with brass bristle

LS Ø17x14 H 7 cm

| Cod. | LM | LT |
|---------------|-----|-----|
| 237504 | 120 | 131 |
| 237506 | 150 | 161 |
| 237508 | 180 | 191 |
| 237509 | 200 | 211 |

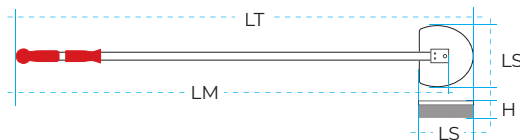



Spazzola forno - Setole ottone

| Oven brush Brass bristle | Cod. | L x W cm | H cm |
|-----------------------------|---------------|----------|------|
| | 237900 | 20 x 6 | 7 |
| | 237905 | 27 x 6,5 | 7 |



Spazzola forno - Setole naturali

| Oven brush Natural bristle | Cod. | L x W cm | H cm |
|-------------------------------|---------------|----------|------|
| | 237901 | 20 x 6 | 7 |



**Spazzola forno tonda
Setole ottone**

| Round oven brush Brass bristle | Cod. | L x W cm | H cm |
|-----------------------------------|---------------|----------|------|
| | 237920 | Ø17 x 14 | 7 |



**Spazzolone forno rettangolare
"Cambio rapido" - Setole ottone**

| Rectangular brass bristle 'Fast change' oven brush | Cod. | LS cm | LM cm | LT cm |
|---|---------------|--------------|-------|-------|
| | 237206 | 16,5x5,5 H 7 | 150 | 167 |



**Spazzolone forno rettangolare
"Cambio rapido" - Setole naturali**

| Rectangular natur. bristle 'Fast change' oven brush | Cod. | LS cm | LM cm | LT cm |
|--|---------------|--------------|-------|-------|
| | 237216 | 16,5x5,5 H 7 | 150 | 167 |

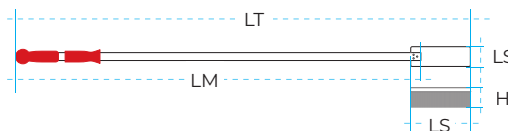

Spazzola forno "Cambio Rapido"

| 'Fast Change' oven brush | Cod. | Mat. |
|--------------------------|---------------|------------------------------|
| | 231000 | ottone/brass |
| | 231100 | setole natur./natur. bristle |



IL SISTEMA DI AGGANCIAMENTO DELLA SPAZZOLA AL MANICO NE CONSENTE LA ROTAZIONE A 360°
THE HOOKING SYSTEM OF BRUSH AND HANDLE ALLOWS A 360° ROTATION



Pala braci

| Charcoal shovel | Cod. | LP cm | LM cm | LT cm |
|-----------------|---------------|-----------|-------|-------|
| | 239006 | 21,5x17,5 | 150 | 171 |

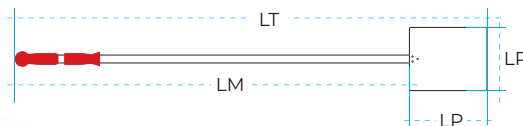

Tirabracci in acciaio

| Oven rake | Cod. | LP cm | LM cm | LT cm |
|-----------|---------------|-------|-------|-------|
| | 239106 | 19 | 150 | 169 |

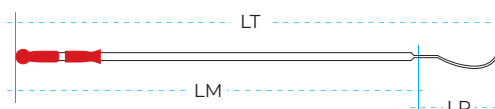

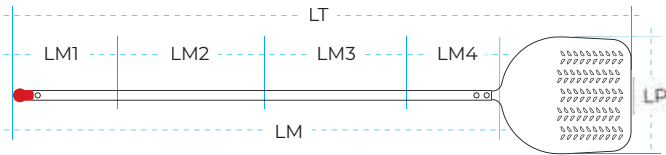

Pala pizza smontabile rettangolare forata in alluminio

Removable rectangular perforated aluminum pizza peel

LP 33 cm

| | | | | | | |
|----------------|-----|-----|-----|-----|-----|-----|
| Cod. | LM1 | LM2 | LM3 | LM4 | LM | LT |
| 235116S | 27 | 50 | 50 | 23 | 150 | 187 |



LE PALE PIZZA SMONTABILI
THE REMOVABLE PIZZA PEELS

- COMODE DA TRASPORTARE CON LA BORSA DA VIAGGIO
- LUNGHEZZA DEL MANICO REGOLABILE A PIACERE
- MONTAGGIO E SMONTAGGIO FACILE E RAPIDO (KIT DI MONTAGGIO INCLUSO)
- MONTAGGIO DI PALETTINO E SPAZZOLONE ANCHE SENZA ATTREZZI (BASTA UNA MONETA)
- EASY TO CARRY WITH THE TRAVEL BAG
- ADJUSTABLE HANDLE LENGTH
- QUICK AND EASY ASSEMBLY AND DISASSEMBLY (ASSEMBLY KIT INCLUDED)
- ASSEMBLY OF THE TURNING PEEL AND OVEN BRUSH EVEN WITHOUT TOOLS (ALL YOU NEED IS A COIN)

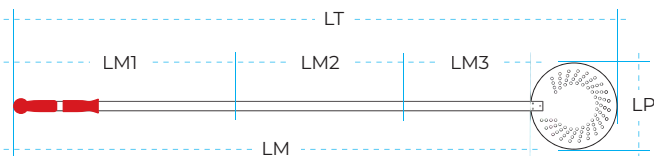
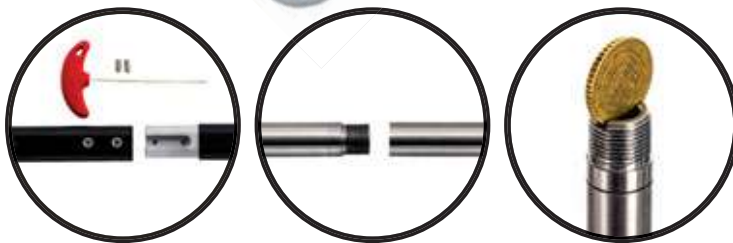

Palettino in inox smontabile forato

Removable perforated stainless steel pizza turning peel

LP Ø20 cm

| | | | | | |
|----------------|-----|-----|-----|-----|-----|
| Cod. | LM1 | LM2 | LM3 | LM | LT |
| 236116S | 60 | 50 | 40 | 150 | 170 |



Spazzolone forno orientabile smontabile - Setole ottone

Removable rotatable oven brush with brass bristle

LS 20x6 H 7 cm

| | | | | | |
|----------------|-----|-----|-----|-----|-----|
| Cod. | LM1 | LM2 | LM3 | LM | LT |
| 237006S | 60 | 50 | 46 | 156 | 163 |



NEW



Borsa da viaggio pizzaiolo

| Pizza Chef travel bag | Cod. | L x W cm | H cm |
|-----------------------|---------------|----------|------|
| | 239910 | 75 x 46 | 6 |

NEW



Borsa da viaggio pizzaiolo - Kit 1

| Pizza Chef travel bag Kit 1 | Cod. | L x W cm | H cm |
|-----------------------------|---------------|----------|------|
| | 239911 | 75 x 46 | 6 |

NEW



Borsa da viaggio pizzaiolo - Kit 2

| Pizza Chef travel bag Kit 2 | Cod. | L x W cm | H cm |
|-----------------------------|---------------|----------|------|
| | 239912 | 75 x 46 | 6 |

IL KIT 1 COMPRENDE I SEGUENTI ARTICOLI
THE KIT 1 INCLUDES THE FOLLOWING ITEMS

- 240210 SPATOLA TRIANGOLARE 10x12 CM TRIANGLE SPATULA 10x12 CM
- 241110 ROTELLA TAGLIAPIZZA Ø10 CM PIZZA WHEEL CUTTER Ø10 CM
- 240601 RASCHIA 12x9,5 CM SCRAPER 12x9,5 CM
- 15790900 MESTOLO PIZZA NYLON & FIBERGLASS PIZZA LADLE
- 014500 MOLLA DI PRECISIONE 30 CM PRECISION TONGS 30 CM
- 239910 BORSA DA VIAGGIO PIZZAIOLO PIZZA CHEF TRAVEL BAG
- 235116S PALA PIZZA SMONTABILE REMOVABLE PIZZA PEEL
- 236116S PALETTINO PIZZA SMONTABILE REMOVABLE TURNING PEEL

IL KIT 2 COMPRENDE I SEGUENTI ARTICOLI
THE KIT 2 INCLUDES THE FOLLOWING ITEMS

- 240210 SPATOLA TRIANGOLARE 10x12 CM TRIANGLE SPATULA 10x12 CM
- 241110 ROTELLA TAGLIAPIZZA Ø10 CM PIZZA WHEEL CUTTER Ø10 CM
- 240601 RASCHIA 12x9,5 CM SCRAPER 12x9,5 CM
- 15790900 MESTOLO PIZZA NYLON & FIBERGLASS PIZZA LADLE
- 014500 MOLLA DI PRECISIONE 30 CM PRECISION TONGS 30 CM
- 239910 BORSA DA VIAGGIO PIZZAIOLO PIZZA CHEF TRAVEL BAG
- 235116S PALA PIZZA SMONTABILE REMOVABLE PIZZA PEEL
- 236116S PALETTINO PIZZA SMONTABILE REMOVABLE TURNING PEEL
- 237006S SPAZZOLONE ORIENTABILE SMONTABILE REMOVABLE ROTABLE OVEN BRUSH

COMPONI IL TUO SET PIZZERIA CREATO SU MISURA IN BASE ALLE TUE ESIGENZE
CREATE YOUR OWN PIZZERIA SET TAILORED TO YOUR NEEDS



SCEGLI GLI ARTICOLI CHE TI SERVONO ALL'INTERNO DELLA SEZIONE PIZZERIA
CHOOSE THE ITEMS YOU NEED IN THE PIZZERIA SECTION



PRENDI NOTA DEL CODICE DEL PRODOTTO
NOTE THE ITEM CODE



INVIACI UNA MAIL CON LA TUA RICHIESTA
SEND US AN EMAIL WITH YOUR REQUEST
piazza@piazza.it



VERRAI RICONTATTATO DA NOI QUANTO PRIMA
WE WILL CONTACT YOU AS SOON AS POSSIBLE

LINEA TRADIZIONE TRADITION LINE

**GRAZIE AL DESIGN DI MICHELE CAPUANI
LA NUOVA IMPUGNATURA IN LEGNO
RINNOVA E AGGIORNA I TRADIZIONALI
PRODOTTI PIZZERIA PIAZZA RENDENDOLI
PIÙ EFFICIENTI, PIÙ PRATICI E ANCORA PIÙ BELLI**

THANKS TO THE DESIGN BY MICHELE CAPUANI
THE NEW WOODEN HANDLE RENEWS
AND UPDATES PIAZZA PIZZERIA TRADITIONAL
PRODUCTS MAKING THEM MORE EFFICIENT,
MORE PRACTICAL AND EVEN MORE BEAUTIFUL



**Pala pizza rettangolare
in alluminio**

Rectangular
aluminum pizza peel

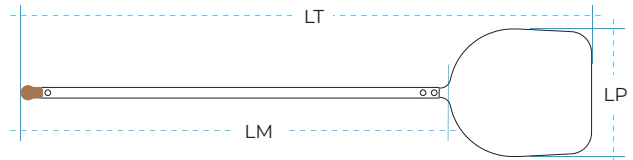

LP 33 cm

| Cod. | LM | LT |
|---------------|-----|-----|
| 230433 | 150 | 187 |

LP 36 cm

| Cod. | LM | LT |
|---------------|-----|-----|
| 230436 | 150 | 190 |

LP 40 cm

| Cod. | LM | LT |
|---------------|-----|-----|
| 230440 | 150 | 194 |

LP 45 cm

| Cod. | LM | LT |
|---------------|-----|-----|
| 230445 | 150 | 200 |

LP 50 cm

| Cod. | LM | LT |
|---------------|-----|-----|
| 230450 | 150 | 205 |



Palettino pizza

Pizza turning peel

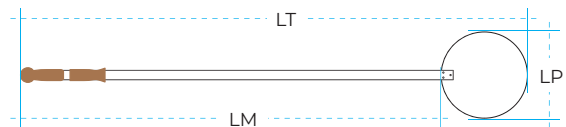

LP Ø18 cm

| Cod. | LM | LT |
|---------------|-----|-----|
| 230018 | 150 | 168 |

LP Ø20 cm

| Cod. | LM | LT |
|---------------|-----|-----|
| 230020 | 150 | 170 |

LP Ø22 cm

| Cod. | LM | LT |
|---------------|-----|-----|
| 230022 | 150 | 172 |

LP Ø24 cm

| Cod. | LM | LT |
|----------------|-----|-----|
| 2300024 | 150 | 174 |



Palettino pizza forato

Perforated pizza turning peel

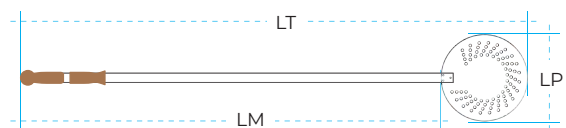

LP Ø18 cm

| Cod. | LM | LT |
|---------------|-----|-----|
| 232018 | 150 | 168 |

LP Ø20 cm

| Cod. | LM | LT |
|---------------|-----|-----|
| 232020 | 150 | 170 |

LP Ø22 cm

| Cod. | LM | LT |
|---------------|-----|-----|
| 232022 | 150 | 172 |

LP Ø24 cm

| Cod. | LM | LT |
|----------------|-----|-----|
| 2320024 | 150 | 174 |





IL FISSAGGIO PALA-MANICO
THE SHOVEL-HANDLE FIXING



LO SMUSSO DELLA PALA
THE SHOVEL'S BEVEL



Pala braci

Charcoal shovel : Cod. LP cm LM cm LT cm
230600 21,5x17,5 150 171

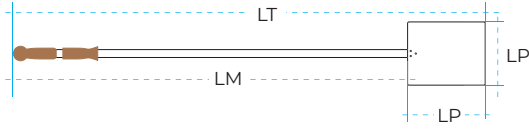

Tirabrazi in acciaio

Oven rake : Cod. LP cm LM cm LT cm
230700 19 150 169

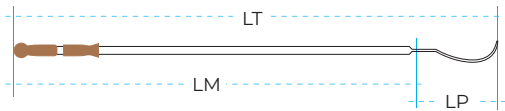

Spazzolone forno rettangolare "Cambio rapido" - Setole ottone

Rectangular brass bristle 'Fast change' oven brush : Cod. LS cm LM cm LT cm
231200 16,5x5,5 H 7 150 167



Spazzolone forno rettangolare "Cambio rapido" - Setole naturali

Rectangular nat. bristle 'Fast change' oven brush : Cod. LS cm LM cm LT cm
231300 16,5x5,5 H 7 150 167

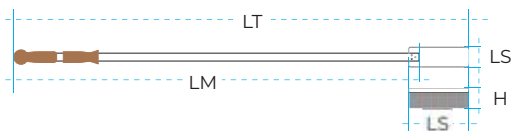

Pala pizza rettangolare in legno

Rectangular wooden pizza peel

LP 33 cm

LP 36 cm

LP 40 cm

Cod. LM LT : Cod. LM LT : Cod. LM LT
238016 153 187 **238026** 153 190 **238036** 153 194

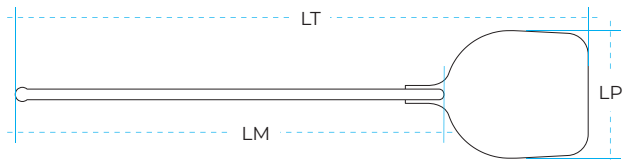

- REALIZZATA IN LEGNO DI FAGGIO MASSICCIO EVAPORATO, LA CUI PARTICOLARE DUREZZA GARANTISCE ROBUSTEZZA E DURATA NEL TEMPO
- RINFORZATA CON BARRE DI ACCIAIO INOX INTERNE.
- SPESSORE: 12 MM.
- IL TRATTAMENTO CON OLIO ENOLOGICO, CERTIFICATO PER USO ALIMENTARE, RIDUCE L'USURA E AL CONTEMPO FAVORISCE LO SCORRIMENTO DELL'IMPASTO
- ANCH'ESSA SMUSSATA SU TRE LATI, PER FAVORIRE, SIA IL TRASCINAMENTO DELL'IMPASTO SULLA PALA CHE IL SOLLEVAMENTO DELLA PIZZA

- MADE OF EVAPORATED SOLID BEECH WOOD, WHOSE PARTICULAR HARDNESS GUARANTEES STURDINESS AND DURABILITY

- REINFORCED WITH INTERNAL STAINLESS STEEL BARS

- THICKNESS: 12 MM.

- THE TREATMENT WITH OENOLOGICAL OIL, CERTIFIED FOR FOOD USE, REDUCES WEAR AND AT THE SAME TIME FAVORS THE FLOW OF THE DOUGH

- ALSO BEVELED ON THREE SIDES, IN ORDER TO FACILITATE BOTH THE DRAGGING OF THE DOUGH ON THE PIZZA PEEL AND THE LIFTING OF THE PIZZA

MANICO IN LEGNO

- OVALE A FACCE PARALLELE
- SPESSORE: 15 MM.

WOODEN HANDLE

- OVAL WITH PARALLEL FACES
- THICKNESS: 15 MM.

FISSAGGIO DEL MANICO

- CON VITI A SCOMPARSA A GARANTIRE LA MASSIMA SOLIDITÀ DELL'ASSEMBLAGGIO DI PALA E MANICO

FIXING OF THE HANDLE

- WITH CONCEALED SCREWS TO ENSURE MAXIMUM SOLIDITY OF THE ASSEMBLY OF SHOVEL AND PEEL



Pala pizza legno betulla

Birch wooden pizza peel : Cod. L x W cm
248100 29,5 x 42



LINEA GLUTEN FREE GLUTEN FREE LINE

IL POMOLO TERMINALE E LE IMPUGNATURE DI COLORE VERDE CONTRADDISTINGUONO QUESTA LINEA, CHE VANTA LE STESSE CARATTERISTICHE D'ECCELLENZA DELLE ALTRE, RENDENDOLA COSÌ IMMEDIATAMENTE RICONOSCIBILE

THE GREEN KNOB AND HANDLES DISTINCTIVELY DISTINGUISH THIS LINE, WHICH BOASTS THE SAME EXCELLENT FEATURES AS THE OTHERS, MAKING IT IMMEDIATELY RECOGNIZABLE



Pala pizza rettangolare "Gluten Free" in alluminio

Rectangular aluminum pizza peel for 'Gluten Free' products

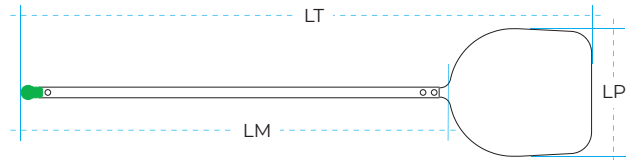

LP 33 cm

| Cod. | LM | LT |
|---------------|-----|-----|
| 235616 | 150 | 187 |

LP 36 cm

| Cod. | LM | LT |
|---------------|-----|-----|
| 235626 | 150 | 190 |



Palettino forato "Gluten Free" in inox

Perforated stainless steel pizza turning peel for 'Gluten Free' products

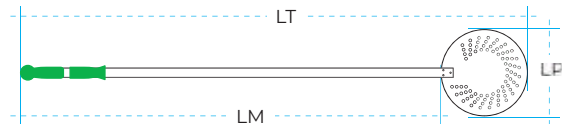

LP Ø20 cm

| Cod. | LM | LT |
|---------------|-----|-----|
| 236316 | 150 | 170 |

LP Ø22 cm

| Cod. | LM | LT |
|---------------|-----|-----|
| 236326 | 150 | 172 |



Spazzolone forno "Gluten Free" orientabile rettangolare - Setole ottone

Rectangular oven brush with rotatable brass bristle for 'Gluten Free' products



LS 20x6 H 7 cm

| Cod. | LM | LT |
|---------------|-----|-----|
| 237056 | 150 | 163 |



1. IMBALLO INDIVIDUALE

Ogni prodotto viene consegnato imballato singolarmente in una scatola in cartone polionda.

2. FACILITÀ DI STOCCAGGIO

Un adesivo esterno con le specifiche del prodotto ne consente l'immediata identificazione all'interno del vostro magazzino.

1. INDIVIDUAL PACKAGING

Each product is delivered individually packed in a corrugated cardboard box.

2. EASE OF STORAGE

An external sticker with product specifications allows immediate identification within your warehouse.



2

1



3. MASSIMA PROTEZIONE

All'interno dell'imballo in cartone un sacchetto in plastica o una scatola (per le spazzole), offrono un'ulteriore protezione alle parti più soggette a urti e graffi.

4. INFORMAZIONI CHIARE

Ogni prodotto è accompagnato da un foglio "parlante" che ne riporta le caratteristiche principali: tipologia, materiale, dimensioni, ecc.

3. MAXIMUM PROTECTION

Inside the cardboard packaging, a plastic bag or a box (for the brushes), offer further protection to the most subject parts to bumps and scratches.

4. CLEAR INFORMATION

Each product is accompanied by a "talking" sheet which shows its main characteristics: type, material, dimensions, etc.



3



4

NEW

LINEA BLUE DROP

BLUE DROP LINE

BLUE DROP È LA NOSTRA NUOVA LINEA PIZZERIA. MASSIMA LEGGEREZZA E GRANDE MANEGGEVOLEZZA D'USO SONO LE CARATTERISTICHE PRINCIPALI DELLE NOSTRE PALE IN ALLUMINIO SENZA ANIMA, DEI PALOTTINI IN INOX E DEGLI SPAZZOLONI CON MANICO IN ACCIAIO E SPAZZOLA ORIENTABILE.

BLUE DROP IS OUR NEW PIZZERIA LINE. MAXIMUM LIGHTNESS AND OUTSTANDING HANDLING ARE THE MAIN FEATURES OF OUR CORELESS ALUMINUM PEELS, OUR STAINLESS STEEL TURNING PEELS AND OUR OVEN BRUSHES WITH STEEL HANDLE AND ADJUSTABLE BRUSH HEAD.



- **LEGGERE MA ROBUSTE**
- **FACILI DA APPENDERE**
- LIGHT BUT STURDY
- EASY HANGING



NEW

Pala pizza rettangolare in alluminio

Rectangular aluminum pizza peel

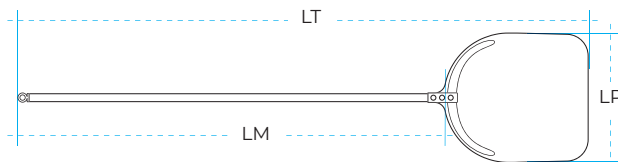

LP 33 cm

| Cod. | LM | LT |
|---------------|-----|-----|
| 232513 | 90 | 126 |
| 232514 | 120 | 156 |
| 232516 | 150 | 186 |

LP 36 cm

| Cod. | LM | LT |
|---------------|-----|-----|
| 232523 | 90 | 130 |
| 232524 | 120 | 160 |
| 232526 | 150 | 190 |



NEW

Pala pizza rettangolare forata in alluminio

Rectangular perforated aluminum pizza peel

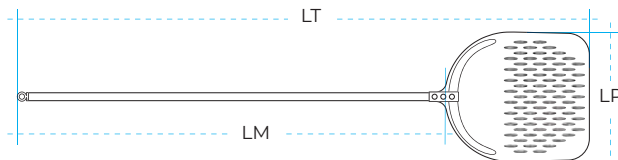

LP 33 cm

| Cod. | LM | LT |
|---------------|-----|-----|
| 232613 | 90 | 126 |
| 232614 | 120 | 156 |
| 232616 | 150 | 186 |

LP 36 cm

| Cod. | LM | LT |
|---------------|-----|-----|
| 232623 | 90 | 130 |
| 232624 | 120 | 160 |
| 232626 | 150 | 190 |



NEW

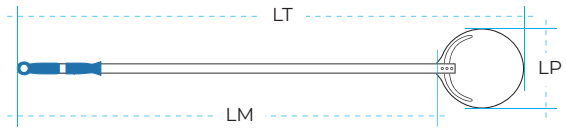

Palettino in inox

Stainless steel pizza turning peel

LP Ø18 cm

| Cod. | LM | LT |
|---------------|-----|-----|
| 233303 | 90 | 109 |
| 233304 | 120 | 139 |
| 233306 | 150 | 169 |

LP Ø20 cm

| Cod. | LM | LT |
|---------------|-----|-----|
| 233323 | 90 | 113 |
| 233324 | 120 | 14 |
| 233326 | 150 | 173 |



NEW

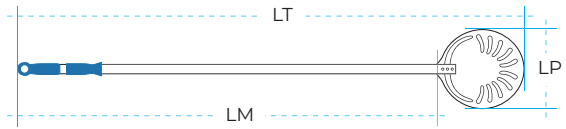

Palettino in inox forato

Perforated stainless steel pizza turning peel

LP Ø18 cm

| Cod. | LM | LT |
|---------------|-----|-----|
| 233403 | 90 | 109 |
| 233404 | 120 | 139 |
| 233406 | 150 | 169 |

LP Ø20 cm

| Cod. | LM | LT |
|---------------|-----|-----|
| 233423 | 90 | 113 |
| 233424 | 120 | 14 |
| 233426 | 150 | 173 |



NEW

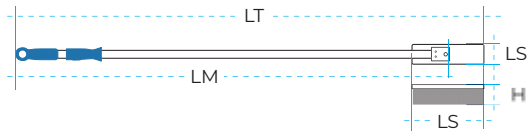

Spazzolone forno orientabile rettangolare - Setole ottone

Rectangular oven brush with rotatable brass bristle

LS 20x6 H 7 cm

| Cod. | LM | LT |
|---------------|-----|-----|
| 233703 | 90 | 102 |
| 233704 | 120 | 132 |
| 233706 | 150 | 162 |



NEW

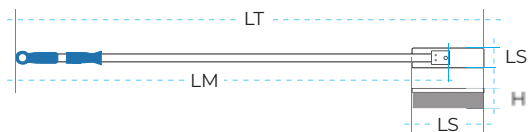

Spazzolone forno orientabile rettangolare - Setole naturali

Rectangular oven brush with rotatable natural bristle

LS 20x6 H 7 cm

| Cod. | LM | LT |
|---------------|-----|-----|
| 233713 | 90 | 102 |
| 233714 | 120 | 132 |
| 233716 | 150 | 162 |



Appendipala inox da parete - 1 posto

St. steel wall mounted
1 place peel rack

| Cod. | L x W cm | H cm |
|--------|----------|------|
| 239501 | 19 x 4 | 6 |



Appendipala inox da parete - 3 posti

St. steel wall mounted
3 places peel rack

| Cod. | L x W cm | H cm |
|--------|----------|------|
| 239503 | 30 x 5 | 5 |



APPENDIPALA 1 POSTO
1 PLACE PEEL RACK



APPENDIPALE 3 POSTI
3 PLACES PEEL RACK

NEW

Appendipala inox da parete - 6 posti

St. steel wall mounted
6 places peel rack

| Cod. | L x W cm | H cm |
|--------|----------|------|
| 239506 | 30 x 5 | 5 |



Portapale con base in marmo

Peel holder with
marble base



NEW

| Cod. | L x W cm | H cm |
|--------|---------------|------|
| 239504 | 29,5 x 29 x 5 | 182 |



PER QUESTO PORTAPALE È DISPONIBILE, SU RICHIESTA, IL CARTELLO AGGANCIABILE MOSTRATO QUI SOTTO
FOR THIS PEEL HOLDER THE ATTACHABLE SIGN, SHOWN HERE BELOW, IS AVAILABLE UPON REQUEST





Spazzola e raschietto 2 usi con setole in inox

2 in 1 brush and scraper with st. steel bristle

| | |
|---------------|------|
| Cod. | L cm |
| 231250 | 23 |



Alare

Fire dog

| | |
|---------------|------|
| Cod. | H cm |
| 231400 | 41 |



Contentore palline per pizza in plastica con coperchio

Plastic box for dough stackable with lid

| | | |
|---------------|----------|------|
| Cod. | L x W cm | H cm |
| 245211 | 60 x 40 | 10 |



NEW

Contentore palline per pizza in plastica

Plastic box for dough stackable

| | | | |
|----------------|----------|------|------|
| Cod. | L x W cm | H cm | Col. |
| 245310 | 40 x 30 | 10 | ○ |
| 2453101 | 40 x 30 | 10 | ● |
| 2453104 | 40 x 30 | 10 | ● |



Contentore palline per pizza in plastica

Plastic box for dough stackable

| | | |
|---------------|----------|------|
| Cod. | L x W cm | H cm |
| 245207 | 60 x 40 | 7 |
| 245210 | 60 x 40 | 10 |



Coperchio contenitore palline per pizza in plastica

Plastic cover

| | |
|---------------|----------|
| Cod. | L x W cm |
| 245400 | 60 x 40 |
| 245401 | 40 x 30 |

NEW



Oliera in rame e ottone

Copper and brass oil cruet

| | |
|---------------|-----|
| Cod. | lt |
| 246005 | 0,5 |
| 246010 | 1 |
| 246015 | 1,5 |



Cucchiaione

Basting spoon

| |
|---------------|
| Cod. |
| 431900 |





Placca alluminio microforata

| | | | |
|----------------------------------|---------------|----------|------|
| Micro-perforated aluminium plate | Cod. | L x W cm | H cm |
| | 251030 | 30 x 40 | 1 |
| | 251032 | 32 x 53 | 1 |
| | 251060 | 40 x 60 | 1 |



Teglia cottura ferro blu diamantata con X di rinforzo

| | | | |
|--|---------------|----------|------|
| Blue iron baking tray with reinforcement X | Cod. | L x W cm | H cm |
| | 252063 | 40 x 60 | 2 |



Teglia cottura ferro blu con pareti dritte

| | | | |
|---|---------------|----------|------|
| Blue iron baking tray with straight edges | Cod. | L x W cm | H cm |
| | 252060 | 40 x 60 | 2 |



Teglia cottura alluminio forata

| | | | |
|----------------------------------|---------------|----------|------|
| Perforated aluminium baking tray | Cod. | L x W cm | H cm |
| | 252161 | 40 x 60 | 2 |



Teglia cottura alluminata con pareti dritte

| | | | |
|--|---------------|----------|------|
| Aluminized baking tray with straight edges | Cod. | L x W cm | H cm |
| | 252061 | 40 x 60 | 2 |



Teglia cottura tonda ferro blu

| | | | |
|-----------------------------|---------------|------|------|
| Round blue iron baking tray | Cod. | Ø cm | H cm |
| | 252514 | 14 | 2,5 |
| | 252516 | 16 | 2,5 |
| | 252518 | 18 | 2,5 |
| | 252520 | 20 | 2,5 |
| | 252522 | 22 | 2,5 |
| | 252524 | 24 | 2,5 |
| | 252526 | 26 | 2,5 |
| | 252528 | 28 | 2,5 |
| | 252530 | 30 | 2,5 |
| | 252532 | 32 | 2,5 |
| | 252536 | 36 | 2,5 |
| | 252540 | 40 | 2,5 |
| | 252545 | 45 | 2,5 |
| | 252550 | 50 | 2,5 |



Teglia cottura alluminata antiaderente con pareti dritte

| | | | |
|--|---------------|----------|------|
| Aluminized baking tray with non stick coating and straight edges | Cod. | L x W cm | H cm |
| | 252062 | 40 x 60 | 2 |





Teglia cottura alluminio

| Round baking tray | Cod. | Ø cm | H cm |
|-------------------|---------------|------|------|
| | 252521 | 20 | 2,5 |
| | 252525 | 24 | 2,5 |
| | 252529 | 28 | 2,5 |
| | 252533 | 32 | 2,5 |



Teglia cottura alluminio

| Aluminium baking tray | Cod. | L x W cm | H cm |
|-----------------------|---------------|----------|------|
| | 253135 | 35 x 35 | 3 |
| | 253140 | 30 x 40 | 3 |
| | 253150 | 35 x 50 | 3 |
| | 253160 | 40 x 60 | 3 |



Teglia cottura ferro blu

| Blue iron baking tray | Cod. | L x W cm | H cm |
|-----------------------|---------------|----------|------|
| | 253030 | 23 x 30 | 3 |
| | 253035 | 28 x 35 | 3 |
| | 253040 | 30 x 40 | 3 |
| | 253045 | 35 x 45 | 3 |
| | 253050 | 35 x 50 | 3 |
| | 253060 | 40 x 60 | 3 |
| | 253065 | 45 x 65 | 3 |



Tortiera alta ferro blu

| Blue iron high-sided cake pan | Cod. | Ø cm | H cm |
|-------------------------------|---------------|------|------|
| | 254014 | 14 | 4 |
| | 254016 | 16 | 4 |
| | 254018 | 18 | 4 |
| | 254020 | 20 | 4 |
| | 254022 | 22 | 4 |
| | 254024 | 24 | 4 |
| | 254026 | 26 | 4 |
| | 254028 | 28 | 4 |
| | 254030 | 30 | 4 |
| | 254032 | 32 | 4 |
| | 254036 | 36 | 4 |
| | 254040 | 40 | 4 |
| | 254045 | 45 | 4 |
| | 254050 | 50 | 4 |
| | 254060 | 60 | 4 |



Teglia cottura ferro blu con pareti svasate

| Blue iron baking tray with flared corners | Cod. | L x W cm | H cm |
|---|---------------|----------|------|
| | 253041 | 30 x 40 | 3 |
| | 253061 | 40 x 60 | 3 |







Spatola angolare

Design by Michele Capuani

Angular spatula

| Cod. | L cm |
|--------|------|
| 240010 | 10 |
| 240022 | 22 |
| 240026 | 26 |
| 240030 | 30 |
| 240036 | 36 |



Spatola forata

Design by Michele Capuani

Perforated spatula

| Cod. | W x L cm |
|--------|----------|
| 240300 | 7,5 x 16 |



Spatola angolare appuntita

Design by Michele Capuani

Tapered point angular spatula

| Cod. | L cm |
|--------|------|
| 240011 | 11 |



Spatola per hamburger

Design by Michele Capuani

Hamburger turner

| Cod. | W x L cm |
|--------|----------|
| 240400 | 7 x 24 |
| 240401 | 14 x 19 |



Spatola diritta

Design by Michele Capuani

Spatula

| Cod. | L cm |
|--------|------|
| 240112 | 12 |
| 240115 | 15 |
| 240120 | 20 |
| 240122 | 22 |
| 240126 | 26 |
| 240130 | 30 |
| 240136 | 36 |



Spatola per pizza

Design by Michele Capuani

Pizza turner

| Cod. | W x L cm |
|--------|----------|
| 240501 | 9 x 15,5 |



LE SPATOLE PROFESSIONALI: PERFETTE IN CUCINA, PIZZERIA, PASTICCERIA
THE PROFESSIONAL SPATULAS: PERFECT FOR RESTAURANTS, PIZZERIAS, PATISSERIES

**MANICO SPECIALE:
ERGONOMICO
E ANTISCIVOLO**

SPECIAL ERGONOMIC
NON-SLIP HANDLE



- LAMA IN ACCIAIO
- ROBUSTE, PRATICHE, FUNZIONALI
- AMPIA DISPONIBILITÀ DI FORME E DIMENSIONI: PIÙ DI 30 MODELLI
- ASOLA PER APPENDERLE PRESENTE SU TUTTA LA SERIE
- DESIGN ITALIANO
- STEEL BLADE
- STURDY, PRACTICAL, FUNCTIONAL
- WIDE RANGE OF SHAPES AND SIZES: MORE THAN 30 ITEMS
- ALL ITEMS HAVE PRACTICAL HANGING LOOPS
- ITALIAN DESIGN



Spatola triangolare

Design by Michele Capuani

Triangle spatula

| Cod. | W x L cm |
|---------------|----------|
| 240208 | 8 x 12 |
| 240210 | 10 x 12 |
| 240212 | 12 x 12 |



Tagliapasta

Design by Michele Capuani

Dough cutter

| Cod. | W x L cm |
|---------------|----------|
| 240600 | 16 x 12 |



Raschia

Design by Michele Capuani

Scraper

| Cod. | W x L cm |
|---------------|----------|
| 240601 | 12 x 9,5 |
| 240640 | 15 x 7,5 |



Raschia

Design by Michele Capuani

Scraper

| Cod. | W x L cm |
|---------------|----------|
| 240700 | 15 x 6 |



Paletta pizza ovale forata

Design by Michele Capuani

Oval perforated pizza turner

| Cod. | W x L cm |
|---------------|----------|
| 240900 | 18 x 22 |



Paletta pizza ovale

Design by Michele Capuani

Oval pizza turner

| Cod. | W x L cm |
|---------------|----------|
| 240901 | 18 x 22 |



Paletta pizza triangolare forata

Design by Michele Capuani

Triangle perforated pizza turner

| Cod. | W x L cm |
|---------------|----------|
| 241000 | 12 x 16 |



Paletta pizza triangolare

Design by Michele Capuani

Triangle pizza turner

| Cod. | W x L cm |
|---------------|----------|
| 241001 | 12 x 16 |



I NUOVI ACCESSORI PIZZERIA: SEMPLICI ED ELEGANTI
THE NEW PIZZERIA ACCESSORIES: SIMPLE AND ELEGANT

La nuova serie di accessori replica il look della collezione "Puntorosso", riprendendone il colore ed il pomolo terminale.

Grazie al design dell'Arch. Michele Capuani si farà notare sia sul banco della vostra pizzeria così come davanti al forno di casa.

- LAMA IN ACCIAIO INOX
- 100% MADE IN ITALY

The new series of accessories replicates the look of the 'Puntorosso' collection, echoing the same color and terminal knob. Thanks to Arch. Michele Capuani's design, it will draw attention both on your pizzeria counter and in front of your home oven.

- STAINLESS STEEL BLADE
- 100% MADE IN ITALY



Tronchetto tagliapizza

Design by Michele Capuani

| | | |
|--------------|---------------|----------|
| Pizza cutter | Cod. | W x L cm |
| | 240800 | 14 x 6 |



Rotella tagliapizza

Design by Michele Capuani

| | | |
|--------------------|---------------|------|
| Pizza wheel cutter | Cod. | Ø cm |
| | 241106 | 5,5 |
| | 241110 | 10 |



Rotella tagliapizza da tavola

Design by Michele Capuani

| | | |
|--------------------------|---------------|------|
| Table pizza wheel cutter | Cod. | Ø cm |
| | 241306 | 6 |



NEW

241206



241209

Rotella tagliapizza

Design by Michele Capuani

| | | |
|--------------------|---------------|------|
| Pizza wheel cutter | Cod. | Ø cm |
| | 241206 | 6 |
| | 241209 | 9 |



LA TRAMA "PUNTINATA" IMPEDISCE AL CONDIMENTO DELLA PIZZA DI ATTACCARSI ALLA LAMA DURANTE IL TAGLIO
THE 'ALVEOLATED' TEXTURE PREVENTS PIZZA TOPS FROM STICKLING TO THE BLADE DURING CUTTING

NEW



Rotella tagliapizza bugnata

Design by Michele Capuani

| | | |
|------------------------------|---------------|------|
| Alveolate pizza wheel cutter | Cod. | Ø cm |
| | 241219 | 9 |



NEW

Forbici da pizza

| | |
|----------------|---------------|
| Pizza scissors | Cod. |
| | 242001 |



NEW

Forbici da tavola

| | |
|----------------|---------------|
| Table scissors | Cod. |
| | 242010 |





PASTICCERIA

PÂTISSERIE

MOLLE E PINZE PER DOLCI
PASTRY TONGS AND SCISSOR SERVERS 114

SACCAPOCHE E BOCCHETTE
PASTRY BAGS AND DECORATING NOZZLES 116

SPATOLE
SPATULAS 120

RULLI E PENNELLI
ROLLING PINS AND PASTRY BRUSHES 122

TAGLIAPASTA E TAGLIABISCOTTI
PASTRY AND BISCUIT CUTTERS 123

MISURINI E STAMPI
MEASURING CUPS AND MOULDS 127

STAMPI E FORME
MOULDS 128

ACCESSORI PASTICCERIA
PÂTISSERIE ACCESSORIES 132



Molla per dolci

| | | | |
|-------------|---------------|------|-----|
| Pastry tong | Cod. | L cm | Box |
| | 010600 | 18 | 12 |



Mollunga per toast e dolci

Design by Michele Capuani

| | | | |
|---------------------------------|---------------|------|-----|
| Buffet toast tong 'Mollunga' | Cod. | L cm | Box |
| | 011000 | 30 | 12 |



Molla per dolci

| | | | |
|-------------|---------------|------|-----|
| Pastry tong | Cod. | L cm | Box |
| | 011900 | 16,5 | 12 |



Molla per toast e dolci

| | | | |
|---------------|---------------|------|-----|
| Ice cube tong | Cod. | L cm | Box |
| | 012500 | 21 | 12 |



CONTROLLATE UNA AD UNA
CHECKED ONE BY ONE

Tutte le nostre molle e pinze in acciaio inox sono interamente prodotte nei nostri stabilimenti. Grazie agli investimenti tecnologici la linea di produzione robotizzata ha ora una potenzialità produttiva di 6.000.000 di molle l'anno. Per diventare una molla PIAZZA però tutte, nessuna esclusa, devono passare l'ultimo esame, il più difficile, uno scrupoloso e certosino controllo manuale della loro precisione di chiusura e della loro straordinaria capacità di conservare l'elasticità nel tempo, una caratteristica questa, dovuta ad un passaggio produttivo che solo noi conosciamo e che ancora gelosamente custodiamo. Sarà per questo che qualcuno ci ha definito "King of Tongs"...

All our stainless steel tongs and scissor servers are produced entirely in our Italian factories. Thanks to investments in technology, our automated line now has production capacity of 6,000,000 tongs a year. However, to become a PIAZZA tong, all of them, without exception, must pass a final exam, the most difficult one: painstaking manual control of their closing accuracy and extraordinary ability to retain their spring over time. This last is a characteristic made possible thanks to a special step in the production process that is known to us alone and jealously guarded. Perhaps this is why we have been called the "King of Tongs"...





Pinza per dolci forgiata

Pastry scissor server

| | |
|---------------|------|
| Cod. | L cm |
| 020000 | 16,5 |



Pinza per torta forgiata

Pie scissor server

| | |
|---------------|------|
| Cod. | L cm |
| 020400 | 25 |



Pinza per dolci forgiata

Pastry scissor server

| | |
|---------------|------|
| Cod. | L cm |
| 020100 | 20 |



Pinza per dolci "Mignon" forgiata

Midget scissor server
'Mignon'

| | |
|---------------|------|
| Cod. | L cm |
| 020700 | 15 |



Pinza per dolci forgiata

Pastry scissor server

| | |
|----------------|------|
| Cod. | L cm |
| 020200 | 20 |
| 0202001 | 20 |



Cod. 0202001



Pinza per dolci "Mignon" forgiata

Midget scissor server
'Mignon'

| | |
|---------------|------|
| Cod. | L cm |
| 020800 | 15 |



Pinza per dolci forgiata

Pastry scissor server

| | |
|----------------|------|
| Cod. | L cm |
| 020300 | 21 |
| 0203001 | 21 |



Cod. 0203001



Pinza per forno

Hot plate holder

| | |
|---------------|------|
| Cod. | L cm |
| 021100 | 18,5 |





Saccapoche nylon "Superflex"

| 'Superflex' nylon pastry bags | Cod. | L cm | Box |
|-------------------------------|----------------|------|-----|
| | 2751252 | 25 | 6 |
| | 2751282 | 28 | 6 |
| | 2751342 | 34 | 6 |
| | 2751402 | 40 | 6 |
| | 2751462 | 46 | 6 |
| | 2751502 | 50 | 6 |
| | 2751552 | 55 | 6 |
| | 2751602 | 60 | 6 |



Saccapoche nylon "Professionale"

| 'Professional' nylon pastry bags | Cod. | L cm | Box |
|----------------------------------|----------------|------|-----|
| | 2753252 | 25 | 6 |
| | 2753282 | 28 | 6 |
| | 2753342 | 34 | 6 |
| | 2753402 | 40 | 6 |
| | 2753462 | 46 | 6 |
| | 2753502 | 50 | 6 |
| | 2753552 | 55 | 6 |
| | 2753602 | 60 | 6 |



Saccapoche monouso in polietilene a rotolo

| Disposable pastry bags - one roll | Cod. | L cm | T μ |
|-----------------------------------|---------------|------|-----|
| | 275501 | 50 | 70 |
| | 275503 | 30 | 70 |
| | 275505 | 40 | 70 |



Set 3 saccapoche "Superflex"

| 3 different pastry bags "Superflex" | Cod. | L cm | Box |
|-------------------------------------|---------------|--------------|-----|
| | 275700 | 34 - 46 - 50 | 6 |





Bocchetta per decorazione acciaio inox foro a stella

| Star decorating nozzle - stainless steel | Cod. | Ø mm |
|--|----------------|------|
| | 2763022 | 2 |
| | 2763032 | 3 |
| | 2763042 | 4 |
| | 2763052 | 5 |
| | 2763062 | 6 |
| | 2763072 | 7 |
| | 2763082 | 8 |
| | 2763092 | 9 |
| | 2763102 | 10 |
| | 2763112 | 11 |
| | 2763122 | 12 |
| | 2763132 | 13 |
| | 2763142 | 14 |
| | 2763152 | 15 |
| | 2763162 | 16 |
| | 2763172 | 17 |
| | 2763182 | 18 |

Bocchetta per decorazione acciaio inox foro tondo

| Plain decorating nozzle - stainless steel | Cod. | Ø mm |
|---|----------------|------|
| | 2764022 | 2 |
| | 2764032 | 3 |
| | 2764042 | 4 |
| | 2764052 | 5 |
| | 2764062 | 6 |
| | 2764072 | 7 |
| | 2764082 | 8 |
| | 2764092 | 9 |
| | 2764102 | 10 |
| | 2764112 | 11 |
| | 2764122 | 12 |
| | 2764132 | 13 |
| | 2764142 | 14 |
| | 2764152 | 15 |
| | 2764162 | 16 |
| | 2764172 | 17 |
| | 2764182 | 18 |
| | 2764202 | 20 |
| | 2764222 | 22 |
| | 2764242 | 24 |



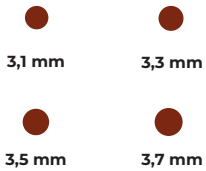

Set per alta decorazione: 4 bocchette foro tondo, portabocchette, saccapoché

Decoration set: 4 nozzles plain, nozzles ring, pastry bag Cod. **276501** L cm 34

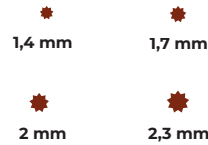

Set per alta decorazione: 4 bocchette foro stella, portabocchette, saccapoché

Decoration set: 4 nozzles star, nozzles ring, pastry bag Cod. **276502** L cm 34

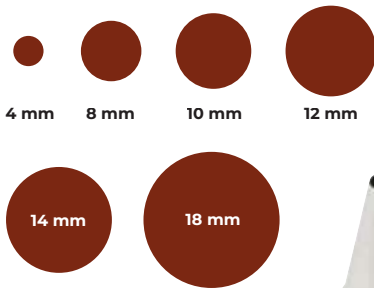

Set 6 bocchette inox foro tondo

Set of 6 stainless steel plain nozzles Cod. **276601**

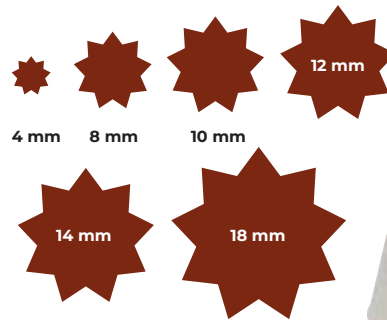

Set 6 bocchette inox foro stella

Set of 6 stainless steel star nozzles Cod. **276602**

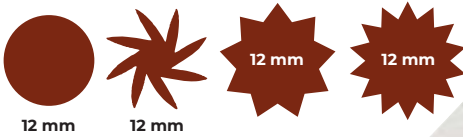

Set decorazione: 4 bocchette inox e saccapoché

Decoration set: 4 stainless steel nozzles + pastry bag Cod. **276603** L cm 34

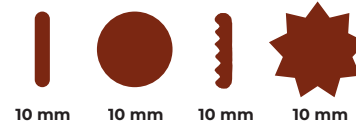

Set decorazione: 4 bocchette inox e saccapoché

Decoration set: 4 stainless steel nozzles + pastry bag Cod. **276604** L cm 34

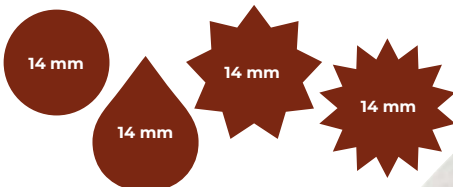

Set decorazione: 4 bocchette inox e saccapoché

Decoration set: 4 stainless steel nozzles + pastry bag Cod. **276605** L cm 34





Set 5 bocchette inox

Set of 5 stainless steel decorating nozzles

Cod. **276703**



Set 5 bocchette inox

Set of 5 stainless steel decorating nozzles

Cod. **276704**



25 mm



Bocchetta Saint-Honoré in acciaio inox

Saint-Honoré decorating nozzle stainless steel

Cod. **277200**



Cannoli cilindrici in latta

Tin cream cylindrical cornet moulds

Cod. **276801**

L cm 13
Ø cm 2
Box 6



Cannoli conici in latta

Tin cream cylindrical cornet moulds

Cod. **276802**

L cm 12
Ø cm 3
Box 6



Cassettina 12 bocchette polipropilene

Polypropylene 12 pcs - nozzles box

Cod. **276902**



Cassettina 12 bocchette polipropilene

Polypropylene 12 pcs - nozzles box

Cod. **276901**



Spatola professionale "Vasetto" in plastica

Professional plastic spatula for jar

| Cod. | L cm |
|---------------|------|
| 285000 | 25 |



Spatola taglia impasti in plastica

Cutter for pies and fat

| Cod. | L cm | Box |
|---------------|------|-----|
| 285112 | 23 | 12 |



Spatola professionale in plastica

Professional plastic spatula

| Cod. | L cm |
|---------------|------|
| 285001 | 25 |
| 285002 | 35 |
| 285003 | 45 |



Set 7 spatole polipropilene

Polypropylene spatulas - 7 pcs

| Cod. | Box |
|---------------|-----|
| 285123 | 10 |



Spatola professionale applicazione in silicone

Professional spatula with silicone blade

| Cod. | L cm |
|---------------|------|
| 285012 | 35 |



Spatolina in plastica

Scraper in polypropylene

| Cod. | L x W cm | Box |
|---------------|------------|-----|
| 285124 | 14,5 x 9,5 | 10 |
| 285125 | 12 x 8,5 | 10 |
| 285126 | 14,5 x 9,5 | 10 |
| 285127 | 12 x 9 | 10 |
| 285128 | 15 x 11 | 10 |



NEW

Spatola professionale in nylon rinforzato con fiberglass

Professional spatula in nylon reinforced with fiberglass

| Cod. | L cm | Box |
|---------------|------|-----|
| 285021 | 30 | 6 |
| 285022 | 35 | 6 |
| 285023 | 40 | 6 |



Spatolina in plastica

Scraper in polystyrene - trapezoidal shape

| Cod. | L x W cm | Box |
|---------------|-----------|-----|
| 285129 | 21,5 x 13 | 10 |





Spatola angolare

Design by Michele Capuani

Angular spatula

| Cod. | L cm |
|---------------|------|
| 240010 | 10 |
| 240022 | 22 |
| 240026 | 26 |
| 240030 | 30 |
| 240036 | 36 |



Spatola angolare appuntita

Design by Michele Capuani

Tapered point angular spatula

| Cod. | L cm |
|---------------|------|
| 240011 | 11 |



Spatola diritta

Design by Michele Capuani

Spatula

| Cod. | L cm |
|---------------|------|
| 240112 | 12 |
| 240115 | 15 |
| 240120 | 20 |
| 240122 | 22 |
| 240126 | 26 |
| 240130 | 30 |
| 240136 | 36 |



Spatola triangolare

Design by Michele Capuani

Triangle spatula

| Cod. | W x L cm |
|---------------|----------|
| 240208 | 8 x 12 |
| 240210 | 10 x 12 |
| 240212 | 12 x 12 |



Rotella liscia

Design by Michele Capuani

Plain wheel cutter

| Cod. | Ø cm |
|---------------|------|
| 241106 | 5,5 |
| 241110 | 10 |



Rotella liscia

Design by Michele Capuani

Plain wheel cutter

| Cod. | Ø cm |
|---------------|------|
| 241206 | 6 |
| 241209 | 9 |



Rotella bugnata

Design by Michele Capuani

Alveolate wheel cutter

| Cod. | Ø cm |
|---------------|------|
| 241219 | 9 |



Rotella ondulata inox, manico plastica

Wheel fluted cutter - st. steel, plastic handle

| Cod. | Ø cm |
|---------------|------|
| 285219 | 5,5 |





Tagliapasta

Design by Michele Capuani

Dough cutter

Cod. **240600** W x L cm
16 x 12



Raschia

Design by Michele Capuani

Scraper

Cod. **240700** W x L cm
15 x 6



Raschia

Design by Michele Capuani

Scraper

Cod. **240601** W x L cm
12 x 9,5
240640 15 x 7,5



Raschietto inox flessibile

Flexible stainless steel desk cleaner

Cod. **285131** L cm Box
12 6



Rullo bucafoglia in plastica

Plastic roller with spikes

Cod. **285302** L cm
12



Rullo losanghe in plastica

Plastic lozenge cutter

Cod. **285304** L cm
285305 6,5
12



Pennello

Baker brush

Cod. **285401** L cm Box
4 12
285402 6 12



Pennello pasticceria

Pastry brush

Cod. **285405** L cm Box
2 12
285406 2,5 12
285409 4 12
285410 5 12
285411 6 12
285412 8 12
285413 10 12



Pennello pasticceria

Pastry brush

Cod. **285415** L cm Box
4 12



Tagliapasta a cuore

Cake cutter - heart

Cod. **285520** Ø cm 6



Scatola 12 tagliapasta in latta, piccoli

Box of 12 pastry cutters in tin - little

Cod. **285526** L cm 1,5



Set 10 tagliapasta assortiti in latta

Tin pastry cutters - different shapes 10 pcs

Cod. **285521** Ø cm 6



Scatola 6 tagliabiscotti a cuore in latta

Box of 6 biscuit cutters in tin - heart

Cod. **285527**



Scatola 14 tagliapasta lisci in latta

Different tin pastry cutters - plain

Cod. **285523** Ø cm 2 → 11



Scatola 6 tagliabiscotti a rosa in latta

Box of 6 biscuit cutters in tin - rose

Cod. **285528**



Set 6 tagliabiscotti a goccia in latta

Set of 6 biscuit cutters in tin - drop

Cod. **285524**



Scatola 6 tagliabiscotti a mezza luna in latta

Box of 6 biscuit cutters in tin - half moon

Cod. **285530**



Scatola 12 tagliapasta in latta, grandi

Box of 12 pastry cutters in tin - big

Cod. **285525**





Tagliabiscotti a pesce piccolo in latta

Fish shaped biscuit cutter in tin - little
 Cod. L x W cm
285531 7,5 x 5



Set 6 tagliabiscotti a trifoglio in latta

Set of 6 biscuit cutters in tin - shamrock
 Cod.
285535



Set 12 tagliabiscotti ad anello frastagliato in latta

Set of 12 indented ring biscuit cutters in tin
 Cod.
285532



Set 6 tagliabiscotti a stella in latta

Set of 6 biscuit cutters in tin - star
 Cod.
285536



Set 6 tagliabiscotti a quadrato lisci in latta

Set of 6 biscuit cutters in tin - plain square
 Cod.
285533



Set 5 tagliabiscotti a quadrato festonati in latta

Set of 5 biscuit cutters in tin - festooned square
 Cod.
285537



Set 6 tagliabiscotti ad esagono in latta

Set of 6 biscuit cutters in tin - hexagon
 Cod.
285534



Set 6 tagliabiscotti ovali in latta

Set of 6 biscuit cutters in tin - oval
 Cod.
285538



Scatola tagliapasta lettere (26 pezzi) in latta

Pastry cutters in tin: alphabet (26 pcs)
 Cod.
285554



Scatola tagliapasta mezzi di trasporto (5 pezzi) in latta

Pastry cutters in tin: vehicles (5 pcs.)
 Cod.
285557



Tagliapasta cerchio liscio in latta con manico

Round pastry cutter in tin with handle, plain : Cod. 285563 Ø cm 6 H cm 3



Tagliapasta cerchio festonato in latta con manico

Round pastry cutter in tin with handle, serrated : Cod. 285564 Ø cm 6 H cm 4



Tagliapasta cerchio liscio in latta

Round pastry cutter in tin with handle, plain : Cod. 285565 Ø cm 10 H cm 3



Tagliapasta inox dentellata

Stainless steel pastry cutter, serrated : Cod. 285569 Ø cm 12



Tagliapasta inox liscia

Stainless steel pastry cutter, plain : Cod. 285570 Ø cm 12



Set 12 tagliapasta inox cerchio dentellato

Pastry cutter ring, serrated (set of 12 pcs.) : Cod. 285571 Ø cm 3 → 14



Set 9 tagliapasta inox cuore dentellato

Pastry cutter heart, serrated (set of 9 pcs.) : Cod. 285572 Ø cm 6 → 14

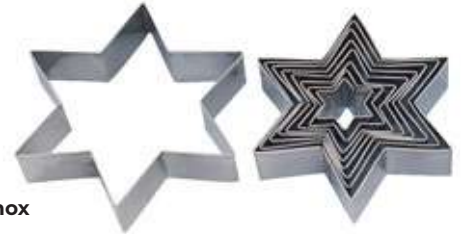

Set 9 tagliapasta inox stella liscia

Pastry cutter star, plain (set of 9 pcs.) : Cod. 285574 Ø cm 3,7 → 15



Set 9 tagliapasta praline inox

Stainless steel praline cutters (set of 9 pcs.) : Cod. 285575 L x W cm 3,5 x 2 - 2,5 x 2,5 - 4 x 2,6 3 x 1,5 - 3,5 x 3 - 4 x 2 2 x 2,3 - 3,5 x 1,8 - Ø2,6



Set 4 tagliapasta assortiti in latta

Set of 4 pcs. pastry cutter in tin : Cod. 285598 L x W cm 8 x 6 H cm 3 Box 6

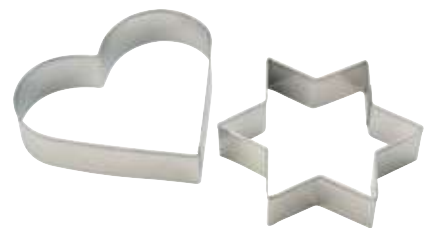

Set 2 tagliapasta assortiti in latta

Set of 2 pcs. pastry cutter in tin : Cod. 285599 L x W cm 12 x 12 H cm 3 Box 6



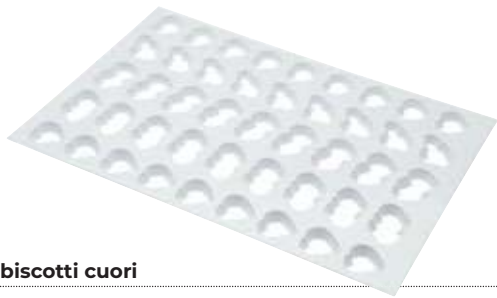

Griglia tagliabiscotti cuori

Sheet of cutters:
hearts

| Cod. | L x W cm | H cm |
|---------------|----------|------|
| 285600 | 60 x 40 | 2 |



Griglia tagliabiscotti mezzi di trasporto

Sheet of cutters:
vehicles

| Cod. | L x W cm | H cm |
|---------------|----------|------|
| 285601 | 60 x 40 | 2 |

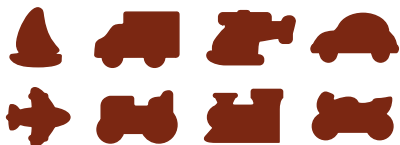

Griglia tagliabiscotti strumenti musicali

Sheet of cutters:
musical instruments

| Cod. | L x W cm | H cm |
|---------------|----------|------|
| 285602 | 60 x 40 | 2 |



Busta per cuoco in carta

Low forage hat

| Cod. | H cm | Box |
|---------------|------|-----|
| 290300 | 8,5 | 30 |



Cappello da cuoco standard in carta

Pleated hat - standard

| Cod. | H cm | Box |
|---------------|------|-----|
| 290400 | 21,6 | 10 |



Sessola in plastica

Flour scoop
in polypropylene

| Cod. | L cm | Box |
|---------------|------|-----|
| 290619 | 19 | 6 |
| 290625 | 25 | 6 |
| 290631 | 31 | 6 |
| 290635 | 35 | 6 |
| 290640 | 40 | 6 |



Misurino in plastica

| Measuring cup | Cod. | lt | Box |
|---------------|---------------|------|-----|
| | 290702 | 0,25 | 6 |
| | 290705 | 0,5 | 6 |
| | 290710 | 1 | 6 |
| | 290720 | 2 | |
| | 290730 | 3 | |
| | 290750 | 5 | |

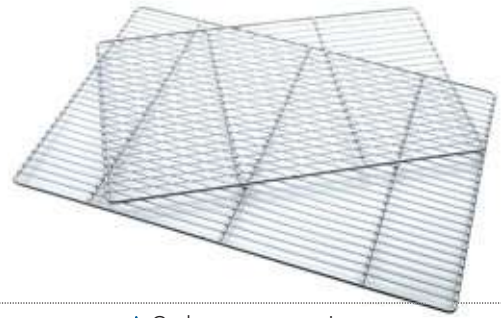

Griglia inox

| Flat rack | Cod. | L cm |
|-----------|---------------|------------------|
| | 291053 | 53 x 32,5 GN 1/1 |
| | 291060 | 60 x 40 |
| | 291065 | 65 x 53 GN 2/1 |



NEW



Misurino in plastica con manico aperto

| Measuring cup with open handle | Cod. | lt |
|--------------------------------|---------------|-----|
| | 290805 | 0,5 |
| | 290810 | 1 |
| | 290820 | 2 |
| | 290830 | 3 |
| | 290850 | 5 |

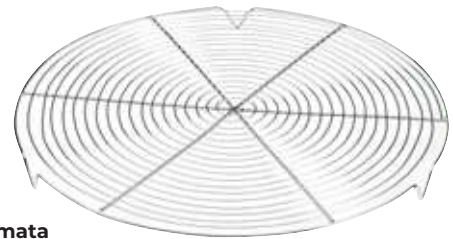

Griglia tonda cromata con piedini

| Cake cooling tray with feet | Cod. | Ø cm |
|-----------------------------|---------------|------|
| | 291066 | 36 |



NEW



Coperchio per misurino in plastica

| Lid for measuring cup | Cod. | lt |
|-----------------------|---------------|-----|
| | 290905 | 0,5 |
| | 290910 | 1 |
| | 290920 | 2 |
| | 290930 | 3 |
| | 290950 | 5 |



Kit 2 stampi semifreddo rettangolari in plastica

| Kit of 2 pcs. plastic semifreddo mould, rectangular | Cod. | L x W cm | H cm | Box |
|---|---------------|------------------------|------------|-----|
| | 291402 | 16 x 32,5 15 x 26,5 | 5,5 4,5 | 6 |



Kit 2 stampi semifreddo quadrati in plastica

| Kit of 2 pcs. plastic semifreddo mould, square | Cod. | L x W cm | H cm | Box |
|--|---------------|------------------------|------------|-----|
| | 291407 | 28,5 x 24 24,5 x 20 | 5,5 4,5 | 6 |





Stampo cassata in alluminio

| | | | |
|-------------------------|---------------|------|------|
| Aluminium cassata mould | Cod. | Ø cm | H cm |
| | 291612 | 12 | 10 |
| | 291613 | 13 | 10,7 |



Stampo cassata conico in alluminio

| | | | |
|---------------------------------|---------------|------|------|
| Aluminium conical cassata mould | Cod. | Ø cm | H cm |
| | 291614 | 10 | 10 |



Stampo zuccotto in alluminio

| | | | |
|----------------------------|---------------|------|------|
| Aluminium 'Zuccotto' mould | Cod. | Ø cm | H cm |
| | 291615 | 23 | 10,5 |



Tortiera conica alta silverstone in alluminio antiaderente

| | | | |
|---|---------------|------|------|
| Silverstone high conical cake tin in aluminium with non stick coating | Cod. | Ø cm | H cm |
| | 291924 | 24 | 6,2 |



Stampo tartelletta tondo dritto in alluminio antiaderente

| | | | |
|---|---------------|------|------|
| Canapé mould round straight in aluminium with non stick coating | Cod. | Ø cm | H cm |
| | 292070 | 7 | 1,8 |



Stampo barchetta in alluminio antiaderente

| | | | |
|--|---------------|----------|------|
| Boat mould in aluminium with non stick coating | Cod. | L x W cm | H cm |
| | 292299 | 10 x 4,3 | 1,3 |



Stampo conico festonato in alluminio

| | | | |
|---------------------------|----------------|------|------|
| Aluminium "Brioche" mould | Cod. | Ø cm | H cm |
| | 2923134 | 12 | 6 |



Stampo conico festonato in alluminio

| | | | |
|---------------------------|---------------|------|------|
| Aluminium "Brioche" mould | Cod. | Ø cm | H cm |
| | 292320 | 20 | 8 |



Stampo conico festonato alto in alluminio

| | | | |
|---------------------------|---------------|------|------|
| Aluminium "Brioche" mould | Cod. | Ø cm | H cm |
| | 292413 | 13 | 10 |



Stampo diamante in alluminio

| | | | |
|---------------------------|---------------|------|------|
| Aluminium "Diamond" mould | Cod. | Ø cm | H cm |
| | 292920 | 20 | 10 |





Photo by Depositphotos



Stampo budino senza orlo quadro in alluminio

Aluminium square pudding mould

Cod. L x W cm
2936074 7 x 7



Stampo budino s/orlo conico liscio in alluminio

Aluminium plain bottom pudding mould

Cod. Ø cm H cm
2933084 8 5



Stampo bocconotto slabbrato in alluminio

Aluminium chipped rim oval pastry mould

Cod. L x W cm H cm
2938104 10 x 7 2



Stampo monodose festonato in alluminio

Aluminium conical shaped mould

Cod. Ø cm H cm
2934084 8 8



Stampo bocconotto alto in alluminio

Aluminium high pastry mould

Cod. Ø cm H cm
2940074 7 3,5



Stampo babà con orlo in alluminio

Aluminium rimmed babà

Cod. Ø cm H cm
2935084 8 9



Set 6 stampini pasticceria in alluminio

Kit of 6 pcs aluminium pastry moulds

Cod. L x W cm
294299 6,5 x 4,5





CONFEZIONE/PAK
6
PEZZI/PIECES

Stampo brioche alto antiaderente

Non sticking high fluted brioche mould

| Cod. | Ø cm | H cm |
|----------------|------|------|
| 2952806 | 8 | 4 |



Tortiera tonda bassa lamiera blu

Blue steel low round baking-pan

| Cod. | Ø cm | H cm | Box |
|---------------|------|------|-----|
| 252522 | 22 | 2,5 | 6 |
| 252524 | 24 | 2,5 | 6 |
| 252526 | 26 | 2,5 | 6 |



CONFEZIONE/PAK
4
PEZZI/PIECES

Stampo ovale festonato antiaderente

Non sticking oval shaped mould

| Cod. | L x W cm | H cm |
|----------------|----------|------|
| 2953104 | 10 x 4 | 4 |



CONFEZIONE/PAK
6
PEZZI/PIECES

Savarin bucata antiaderente

Non sticking savarin mould

| Cod. | Ø cm | H cm |
|----------------|------|------|
| 2958026 | 8 | 4 |



Stampo madeleines multiplo antiaderente

Non sticking multiple madeleines mould

| Cod. | L x W cm | H cm |
|----------------|----------|------|
| 2954400 | 36 x 17 | 2 |



Diplomate/bavarois antiaderente

Non sticking bavarois

| Cod. | Ø cm | H cm |
|---------------|------|------|
| 296002 | 18 | 9 |



Set 4 stampini pasticceria antiaderente

Kit of 4 pcs non sticking small pastry moulds

| Cod. | H cm |
|---------------|------|
| 295500 | 1,5 |





Placca pasta roll. bordata in alluminio antiaderente

| | | | |
|--|---------------|----------|------|
| Baking plate in aluminium with non stick coating | Cod. | L x W cm | H cm |
| | 296004 | 37 x 27 | 2 |



Forma per torta manqué antiaderente

| | | | |
|---------------------------|---------------|----------|------|
| Non sticking square mould | Cod. | L x W cm | H cm |
| | 296008 | 22 x 22 | 5 |



Savarin bucata antiaderente

| | | | |
|----------------------------|---------------|------|------|
| Non sticking savarin mould | Cod. | Ø cm | H cm |
| | 296005 | 24 | 5 |



Forma tonda scanalata bassa antiad. fondo mobile

| | | | |
|--|---------------|------|------|
| Non sticking round mould, fluted edges, loose bottom | Cod. | Ø cm | H cm |
| | 296242 | 30 | 3,5 |
| | 296250 | 32 | 3,5 |



Forma savarin con spirali antiaderente

| | | | |
|--|---------------|------|------|
| Non sticking "trois freres" ring mould | Cod. | Ø cm | H cm |
| | 296006 | 22 | 5 |



Forma torta bordo scanalato antiaderente, fondo mobile

| | | | |
|--|---------------|----------|------|
| Non sticking mould, fluted, loose bottom | Cod. | L x W cm | H cm |
| | 296410 | 23 x 23 | 2,5 |
| | 296910 | 35 x 11 | 2,5 |



Forma per torta manqué antiaderente

| | | | |
|---------------------------|---------------|----------|------|
| Non sticking square mould | Cod. | L x W cm | H cm |
| | 296007 | 24 x 24 | 5 |



Forma torta bordo scanalato antiaderente, fondo mobile

| | | | |
|--|---------------|-----------|------|
| Non sticking mould, fluted, loose bottom | Cod. | L x W cm | H cm |
| | 298110 | 20,5 x 29 | 2,5 |





Alzata girevole in plastica per decorazione torte

Revolving cake stand, plastic

| | | |
|---------------|------|------|
| Cod. | Ø cm | H cm |
| 298200 | 32 | 11 |



Spatola flessibile poliamide antiaderente

Non sticking spatula

| | | |
|---------------|----------|-----|
| Cod. | L x W cm | Box |
| 298210 | 34 x 9 | 12 |

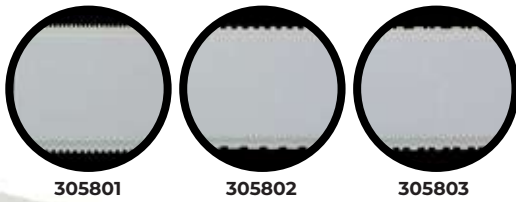

Pettine per decorazioni in plastica

Plastic comb for decoration

| | |
|---------------|------|
| Cod. | L cm |
| 305801 | 70 |
| 305802 | 70 |
| 305803 | 70 |



1. SPATOLARE IN MANIERA UNIFORME LA PASTA PER LA DECORAZIONE SUL TAPPETO ANTIADERENTE
SPREAD THE DECORATION PASTRY UNIFORMLY ON THE NON-STICK MAT



2. APPOGGIARE IL PETTINE PER LA DECORAZIONE SUL FOGLIO E, TIRANDOLO NELLA DIREZIONE DESIDERATA, CREARE IL DECORO. PASSARE IN CONGELATORE
REST THE DECORATING COMB ON THE SHEET AND CREATE THE DECORATION BY DRAWING IT IN THE DESIRED DIRECTION. PUT INTO THE FREEZER



3. STENDERE IN MANIERA UNIFORME LA PASTA PER IL BISCUIT. CUOCERE IN FORNO
SPREAD THE BISCUIT PASTRY UNIFORMLY. BAKE IN THE OVEN



4. TOGLIERE, CON DELICATEZZA, IL TAPPETO ANTIADERENTE
CAREFULLY REMOVE THE NON-STICK MAT



5. CON GLI APPOSITI TAGLIAPASTA REGOLABILI TAGLIARE IL PRODOTTO, CREANDO LE FASCE DI BISCUIT DELLA LARGHEZZA DESIDERATA
WITH THE SPECIAL ADJUSTABLE CUTTERS, CUT THE PRODUCT, CREATING BISCUIT STRIPS OF THE DESIRED WIDTH



Diplomate/bavarois ferro bianco

Tin plate diplomate mould

| Cod. | Ø cm | H cm | Box |
|---------------|------|------|-----|
| 298410 | 16 | 9 | 3 |



306808



306810



306811



306812



306814



306817



Griglia in plastica per decorazione biscuit

Plastic grill for decorated biscuit

| Cod. | L x W cm |
|---------------|----------|
| 306808 | 60 x 40 |
| 306810 | 60 x 40 |
| 306811 | 60 x 40 |
| 306812 | 60 x 40 |
| 306814 | 60 x 40 |
| 306817 | 60 x 40 |



Imbuto colatore inox manico e supporto in plastica

Automatic piston funnel - with plastic handle and stand

| Cod. | Ø cm | Lt |
|---------------|------|-----|
| 305300 | 20 | 0,9 |

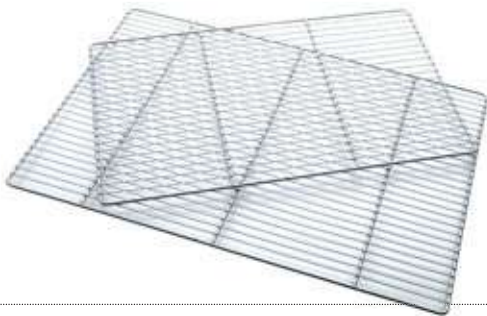

Griglia inox

Flat rack

| Cod. | L cm |
|---------------|------------------|
| 291053 | 53 x 32,5 GN 1/1 |
| 291060 | 60 x 40 |
| 291065 | 65 x 53 GN 2/1 |



Foglio pretagliato neutro

Precut paper

| Cod. | L x W cm |
|---------------|----------|
| 306600 | 60 x 40 |



1. POSIZIONARE LA GRIGLIA SOPRA IL TAPPETO ANTIADERENTE E SPATOLARE IN MANIERA UNIFORME LA PASTA PER LA DECORAZIONE

POSITION THE GRILLE ABOVE THE NON-STICK MAT AND UNIFORMLY SPREAD THE PASTRY FOR DECORATION



2. SOLLEVARE CON DELICATEZZA LA GRIGLIA, LA VOSTRA DECORAZIONE È PRONTA PER ESSERE POSTA NEL CONGELATORE

GENTLY RAISE THE GRILLE. YOUR DECORATION IS READY TO BE PLACED IN THE FREEZER



Alzata per dolci

| Cake stand | Cod. | Ø cm | H cm |
|---|---------------|------|------|
|  | 420424 | 24 | 9 |



Espositore per torta

| Cake stand | Cod. | Ø cm | H cm |
|---|---------------|------|------|
|  | 420507 | 20 | 7 |
| | 420511 | 20 | 11 |
| | 420515 | 20 | 15 |
| | 420607 | 25 | 7 |
| | 420611 | 25 | 11 |
| | 420615 | 25 | 15 |
| | 420707 | 30 | 7 |
| | 420711 | 30 | 11 |
| | 420715 | 30 | 15 |



Anello inox tondo

| Stainless steel mousse ring | Cod. | Ø cm | H cm |
|---|---------------|------|------|
|  | 701410 | 10 | 4 |
| | 701412 | 12 | 4 |
| | 701414 | 14 | 4 |
| | 701418 | 18 | 4 |
| | 701420 | 20 | 4 |
| | 701422 | 22 | 4 |
| | 701426 | 26 | 4 |
| | 701428 | 28 | 4 |
| | 701430 | 30 | 4 |



Quadrato inox

| Stainless steel square | Cod. | Ø cm | H cm |
|---|---------------|---------|------|
|  | 705418 | 18 x 18 | 4 |
| | 705420 | 20 x 20 | 4 |
| | 705422 | 22 x 22 | 4 |
| | 705424 | 24 x 24 | 4 |
| | 705426 | 26 x 26 | 4 |
| | 705428 | 28 x 28 | 4 |





TAVOLA

TABLEWARE

LINEE POSATERIA
CUTLERY LINES

138

POSATERIA SPECIALE
SPECIAL CUTLERY

144

VASSOI
TRAYS

146

COMPLEMENTI TAVOLA
TABLE COMPLEMENTS

148



310001



310002



310003



310004



310021



310022



310023



310031



310033



310034

Parigi



| | Cod. | L cm | T mm |
|---|---------------|------|------|
| Cucchiaio tavola Table spoon | 310001 | 20,6 | 3 |
| Cucchiaio frutta Dessert spoon | 310002 | 18 | 3 |
| Cucchiaino thé e caffè Tea spoon | 310003 | 14 | 3 |
| Cucchiaino moka Moka spoon | 310004 | 11,5 | 3 |
| Forchetta tavola Table fork | 310021 | 20,6 | 3 |
| Forchetta frutta Dessert fork | 310022 | 18 | 3 |
| Forchetta pesce Fish fork | 310023 | 18 | 3 |
| Coltello tavola Table knife | 310031 | 23,8 | 3 |
| Coltello frutta Dessert knife | 310033 | 21 | 3 |
| Coltello pesce Fish knife | 310034 | 21 | 3 |



IL CODICE IN COLORE INDICA CHE LA CONFEZIONE CONTIENE 12 PEZZI
THE COLOR CODE INDICATES THAT THE PACKAGE CONTAINS 12 PIECES



310101



310102



310103



310104



310121



310122



310123



310124



310131



310133



310134



310150

Vienna

| | Cod. | L cm | T mm |
|---|---------------|------|------|
| Cucchiaino tavola Table spoon | 310101 | 20,6 | 3 |
| Cucchiaino frutta Dessert spoon | 310102 | 18 | 3 |
| Cucchiaino thé e caffè Tea spoon | 310103 | 14 | 3 |
| Cucchiaino moka Moka spoon | 310104 | 11,5 | 3 |
| Forchetta tavola Table fork | 310121 | 20,6 | 3 |
| Forchetta frutta Dessert fork | 310122 | 18 | 3 |
| Forchetta pesce Fish fork | 310123 | 18 | 3 |
| Forchettina torta Cake fork | 310124 | 16,5 | 3 |
| Coltello tavola Table knife | 310131 | 23,8 | 3 |
| Coltello frutta Dessert knife | 310133 | 21 | 3 |
| Coltello pesce Fish knife | 310134 | 21 | 3 |
| Pala torta Cake server | 310150 | 26 | 3 |



IL CODICE IN COLORE INDICA CHE LA CONFEZIONE CONTIENE 12 PEZZI
THE COLOR CODE INDICATES THAT THE PACKAGE CONTAINS 12 PIECES

PIAZZA



310201



310202



310203



310204



310207



310221



310222



310223



310224



310231



310233



310234



310235



310236



310250



310251



310252



310253



310254



310255

Roma



| | Cod. | L cm | T mm |
|---|---------------|------|------|
| Cucchiaio tavola Table spoon | 310201 | 20,6 | 3 |
| Cucchiaio frutta Dessert spoon | 310202 | 18 | 3 |
| Cucchiaino thé e caffè Tea spoon | 310203 | 14 | 3 |
| Cucchiaino moka Moka spoon | 310204 | 11,5 | 3 |
| Cucchiaino bibita Cocktail spoon | 310207 | 20 | 3 |
| Forchetta tavola Table fork | 310221 | 20,6 | 3 |
| Forchetta frutta Dessert fork | 310222 | 18 | 3 |
| Forchetta pesce Fish fork | 310223 | 18 | 3 |
| Forchettina torta Cake fork | 310224 | 16,5 | 3 |
| Coltello tavola Table knife | 310231 | 23,8 | 3 |
| Coltello frutta Dessert knife | 310233 | 21 | 3 |
| Coltello pesce Fish knife | 310234 | 21 | 3 |
| Spalmaburro Butter spreader | 310235 | 17 | 3 |
| Coltello bistecca Steak knife | 310236 | 25 | 3 |
| Pala torta Cake server | 310250 | 26 | 3 |
| Cucchiaione legumi Vegetable spoon | 310251 | 23 | 3 |
| Forchettone legumi Vegetable fork | 310252 | 23 | 3 |
| Posate insalata Salad servers | 310253 | 23 | 3 |
| Mestolo a servire Serving ladle | 310254 | 27 | 3 |
| Mestolo salsa Gravy ladle | 310255 | 17,7 | 3 |



CONFEZIONE
12
PEZZI/PIECES

IL CODICE IN COLORE INDICA CHE LA CONFEZIONE CONTIENE 12 PEZZI
THE COLOR CODE INDICATES THAT THE PACKAGE CONTAINS 12 PIECES



310301



310302



310303



310304



310321



310322



310323



310324



310331



310333



310334



310336



310350



310351



310352

Copenhagen

Design by Michele Capuani

| | Cod. | L cm | T mm |
|--|---------------|------|------|
| Cucchiaino tavola Table spoon | 310301 | 20,6 | 3 |
| Cucchiaino frutta Dessert spoon | 310302 | 18,7 | 3 |
| Cucchiaino thé e caffè Tea spoon | 310303 | 15 | 3 |
| Cucchiaino moka Moka spoon | 310304 | 12,3 | 3 |
| Forchetta tavola Table fork | 310321 | 20,6 | 3 |
| Forchetta frutta Dessert fork | 310322 | 18,6 | 3 |
| Forchetta pesce Fish fork | 310323 | 19,1 | 3 |
| Forchettina torta Cake fork | 310324 | 16,5 | 3 |
| Coltello tavola Table knife | 310331 | 23,2 | 3 |
| Coltello frutta Dessert knife | 310333 | 21 | 3 |
| Coltello pesce Fish knife | 310334 | 21,3 | 3 |
| Coltello bistecca Steak knife | 310336 | 24,2 | 3 |
| Pala torta Cake server | 310350 | 26,5 | 3 |
| Cucchiaino legumi Vegetable spoon | 310351 | 26 | 3 |
| Forchettone legumi Vegetable fork | 310352 | 26 | 3 |



CONFEZIONE 12 PEZZI
12
PIECES

IL CODICE IN COLORE INDICA CHE LA CONFEZIONE CONTIENE 12 PEZZI
THE COLOR CODE INDICATES THAT THE PACKAGE CONTAINS 12 PIECES

ALLAN BAY TABLEWARE COLLECTION



La conoscenza di Allan Bay sulle tendenze e sull'evoluzione della ristorazione, si unisce all'esperienza produttiva di Piazza per creare una speciale collezione tavola.

Sette pezzi, tutti rigorosamente in acciaio inox 18/10, che risolvono perfettamente ogni utilizzo di qualunque "mise en place", dalla tradizionale sino alla più moderna.

Allan Bay's understanding of current trends and evolution of restaurant meets Piazza's production skills to create a special collection of tableware.

Seven pieces that perfectly fits all your 'mise en place' needs, from the traditional to the most modern.

NEW**La Molla "Allan Bay"**

'Allan Bay' tongs

Cod.

013000

Box

6

**NEW**
 CONFEZIONE
6
 PEZZI/PIECES
La Forchetta "Allan Bay"

'Allan Bay' fork

Cod.

315025**NEW**
 CONFEZIONE
6
 PEZZI/PIECES
La Spatola "Allan Bay"

'Allan Bay' spatula

Cod.

315035**NEW**
 CONFEZIONE
6
 PEZZI/PIECES
Il Coltello "Allan Bay"

'Allan Bay' knife

Cod.

315036**NEW**
 CONFEZIONE
6
 PEZZI/PIECES
Il Salsacoltello "Allan Bay"

'Allan Bay' cutting spoon

Cod.

315056**NEW**
 CONFEZIONE
6
 PEZZI/PIECES
Il Cucchiaino "Allan Bay"

'Allan Bay' spoon

Cod.

315060**NEW****Il Vassoietto "Allan Bay"**

'Allan Bay' tray

Cod.

315090





Pala per torta a coltello unipezzo

| | | |
|----------------------|---------------|------|
| Decorated pie server | Cod. | L cm |
| | 320000 | 31 |



Pala per torta triangolare manico bianco

| | | |
|-------------------------|----------------|------|
| Pie server white handle | Cod. | L cm |
| | 3205001 | 25 |



Pala per torta unipezzo

| | | |
|----------------------|---------------|------|
| Decorated pie server | Cod. | L cm |
| | 320200 | 30 |



Pala per torta triangolare

| | | |
|------------|---------------|------|
| Pie server | Cod. | L cm |
| | 320600 | 25 |



Pala per torta a lama dentellata unipezzo

| | | |
|-------------------------------|---------------|------|
| Serrated decorated pie server | Cod. | L cm |
| | 320300 | 30 |



Pala per pasta al forno

| | | |
|---------------|----------------|------|
| Gratin server | Cod. | L cm |
| | 320800 | 29 |
| | 3208001 | 29 |



Cod. 3208001





Cucchiaine per servire

| Serving spoon | Cod. | L cm | Finitura/Finishing |
|---------------|---------------|------|-------------------------------|
| | 320900 | 26 | Lucido/Bright |
| | 320901 | 26 | Lucido ornato/Bright decorat. |
| | 320902 | 26 | Satinato ornato/Matt decorat. |



Forchetta per ostrica

| Oyster fork | Cod. | L cm |
|-------------|---------------|------|
| | 321500 | 15 |



Posate per insalata

| Salad servers | Cod. | L cm |
|---------------|----------------|------|
| | 3211001 | 27,5 |



Forchetta scavino per aragosta

| Lobster pick | Cod. | L cm |
|--------------|---------------|------|
| | 321600 | 20 |



Mestolino per sugo, tipo normale

| Sauce ladle | Cod. | L cm |
|-------------|---------------|------|
| | 321200 | 16 |



Pinza per aragosta

| Lobster pincer | Cod. | L cm |
|----------------|---------------|------|
| | 321700 | 18,5 |



Mestolino per sugo con separatore grasso/magro

| Sauce ladle fat separator | Cod. | L cm |
|---------------------------|---------------|------|
| | 321201 | 16 |



Cucchiaino per marmellata

| Jam spoon | Cod. | L cm |
|-----------|---------------|------|
| | 321800 | 19 |



Forchettina per lumache

| Snail fork | Cod. | L cm |
|------------|---------------|------|
| | 321400 | 14 |



Cucchiaino per bibita

| Beverage spoon | Cod. | L cm |
|----------------|---------------|------|
| | 321900 | 20 |





Vassoio rettangolare per bar in acciaio

Rectangular steel bar tray

| Cod. | L x W cm |
|---------------|-----------|
| 360025 | 25 x 19,5 |
| 360029 | 29 x 22 |
| 360034 | 34 x 27 |
| 360040 | 40 x 32 |
| 360046 | 46 x 35 |
| 360052 | 52 x 38 |
| 360060 | 60 x 45 |



Vassoio rettangolare per bar in acciaio con maniglie

Rectangular steel bar tray with handles

| Cod. | L x W cm |
|---------------|----------|
| 360240 | 40 x 32 |
| 360246 | 46 x 35 |
| 360252 | 52 x 38 |
| 360260 | 60 x 45 |



Vassoio ovale per bar in acciaio

Oval steel bar tray

| Cod. | L x W cm |
|---------------|----------|
| 360419 | 19 x 14 |
| 360423 | 23 x 18 |
| 360426 | 26 x 20 |



Vassoio rettangolare laminato antiscivolo

Rectangular laminated tray with non slip treatment

| Cod. | L x W cm | Box |
|---------------|-------------------------|-----|
| 361000 | 37 x 53 EN | 12 |
| 361100 | 32,5 x 53 GN 1/1 | 12 |
| 361200 | 36 x 46 | 12 |
| 361300 | 32 x 44 | 12 |
| 361400 | 33 x 43 | 12 |
| 361500 | 24,5 x 34 | 12 |
| 361600 | 28 x 20 | 12 |



Vassoio rettangolare laminato

Rectangular laminated tray

| Cod. | L x W cm | Box |
|---------------|-------------------------|-----|
| 361001 | 37 x 53 EN | 12 |
| 361101 | 32,5 x 53 GN 1/1 | 12 |
| 361201 | 36 x 46 | 12 |
| 361501 | 24,5 x 34 | 12 |



Vassoio trapezoidale laminato antiscivolo

Trapezoidal laminated tray with non slip treatment

| Cod. | L x W cm | Box |
|---------------|----------|-----|
| 362500 | 36 x 52 | 12 |



Vassoio trapezoidale laminato

Trapezoidal laminated tray

| Cod. | L x W cm | Box |
|---------------|----------|-----|
| 362501 | 36 x 52 | 12 |



Vassoio trapezoidale laminato antiscivolo

Trapezoidal laminat. tray with non slip treatment

| Cod. | L x W cm | Box |
|---------------|----------|-----|
| 362600 | 33 x 47 | 12 |





Vassoio ovale laminato antiscivolo

| Oval laminated tray with non slip treatment | Cod. | L x W cm | Box |
|---|---------------|-----------|-----|
| | 363000 | 27 x 38 | 12 |
| | 363100 | 20 x 26,5 | 12 |



Vassoio rettangolare Rubberform antiscivolo

| Rectangular Rubberform tray with non slip treatment | Cod. | L x W cm | Box |
|---|---------------|---------------------------|-----|
| | 366001 | 37 x 53 EN | 12 |
| | 366101 | 32,5 x 53 GN 1/1 | 12 |
| | 366201 | 36 x 46 | 12 |
| | 366301 | 33 x 43 | 12 |
| | 366401 | 20 x 28 | 12 |
| | 366501 | 26,5 x 32,5 GN 1/2 | 12 |



Vassoio rotondo laminato antiscivolo

| Round laminated tray with non slip treatment | Cod. | Ø cm | Box |
|--|---------------|------|-----|
| | 363500 | 43 | 12 |
| | 363600 | 38 | 12 |
| | 363700 | 32 | 12 |



Vassoio ovale Rubberform antiscivolo

| Oval Rubberform tray with non slip treatment | Cod. | L x W cm | Box |
|--|---------------|-----------|-----|
| | 367001 | 21 x 29 | 12 |
| | 367101 | 20 x 26,5 | 12 |
| | 367301 | 44 x 58 | 12 |



Vassoio rettangolare KAU Polyform antiscivolo

| Rectangular KAU Polyform tray with non slip treatment | Cod. | L x W cm | Box |
|---|---------------|-------------------------|-----|
| | 364000 | 37 x 53 EN | 12 |
| | 364100 | 32,5 x 53 GN 1/1 | 12 |



Vassoio rotondo Rubberform antiscivolo

| Round Rubberform tray with non slip treatment | Cod. | Ø cm | Box |
|---|---------------|------|-----|
| | 367501 | 43 | 12 |
| | 367601 | 38 | 12 |
| | 367701 | 32 | 12 |



Vassoio rotondo KAU Polyform antiscivolo

| Round KAU Polyform tray with non slip treatment | Cod. | Ø cm | Box |
|---|---------------|------|-----|
| | 365500 | 36 | 12 |



Vassoio rettangolare in poliestere rinforzato

| Oval reinforced tray in polyester | Cod. | L x W cm | Box |
|-----------------------------------|---------------|---------------------------|-----|
| | 368000 | 37 x 53 EN | 12 |
| | 368300 | 26,5 x 32,5 GN 1/2 | 12 |



Vassoio ovale in poliestere rinforzato

| Oval reinforced tray in polyester | Cod. | L x W cm | Box |
|-----------------------------------|---------------|----------|-----|
| | 368500 | 21 x 29 | 12 |



Servizio per olio, aceto, sale, pepe, stecchi in filo

Condiment set 5 pcs - wire handle Cod. **330000**



Servizio per olio, aceto, sale, pepe in filo

Condiment set 4 pcs - wire handle Cod. **330100**



Servizio olio e aceto in filo

Oil & vinegar set 2 pcs - wire handle Cod. **330200**



Servizio per sale e pepe in filo

Salt & pepper set 2 pcs - wire handle Cod. **330300**



Servizio per sale, pepe, stecchi in filo

Salt/pepper/toothpick set - wire handle Cod. **330400**



Formaggiera in filo

Parmesan cheese cellar Cod. **330500**



Tappi olio, aceto, spargisale, spargipepe

Oil, vinegar, salt and pepper caps Cod. **330700**
330800
330900



Box
4
4
4

Portastecchi

Toothpick holder Cod. **331100**



Vetro formaggiera, vetro olio e aceto, vetro sale e pepe

Cheese cellar glass, oil and vinegar glass, salt and pepper glass Cod. **331200**
331300
331400



Box
6
6
12

Tappo versatore aceto e olio

Vinegar and oil pourer Cod. **331500**
331600



Box
4
4



NEW

Forbici da tavola

Table scissors

Cod.
242010



NEW

Rotella tagliapizza da tavola

Table pizza wheel cutter

Cod.
241306

Design by Michele Capuani

Ø cm
6



Tagliatartufi inox classico lama dritta

Truffle-slicer, stainless steel plain blade - classic

Cod.
375100



Tagliatartufi inox manico ulivo lama ondulata

Truffle-slicer, stainless steel corrugated blade, olive handle

Cod.
375500



NEW

Bacchette

Chopsticks

Cod.
325001-BL
325002-NE
325003-GR
325004-OR

Col.

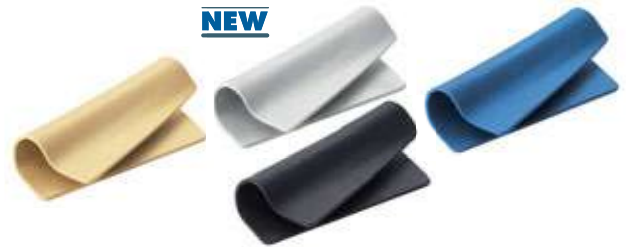

NEW

Base per bacchette

Chopstick rest

Cod.
325011-BL
325012-NE
325013-GR
325014-OR

Col.



NEW

Grattugia

Grater

Cod.
325021-BL
325022-NE
325023-GR
325024-OR

Col.





BAR

| | |
|---|-----|
| MOLLE BAR - TAPPI VERSATORI BAR TONGS - POURERS | 152 |
| VASSOI BAR BAR TRAYS | 156 |
| CAFFETTERIA - GELATERIA COFFEE AND TEA POTS - ICE CREAM SHOP | 158 |
| SHAKER, COLINI, MIXING GLASS SHAKERS, STRAINERS, MIXING GLASSES | 162 |
| JIGGERS | 166 |
| PESTELLI, SESSOLE, CUCCHIAI PESTLES, ICE SCOOPS, MIXING SPOONS | 168 |
| MUGS | 170 |
| ACCESSORI BAR BAR ACCESSORIES | 173 |
| APPARECCHI ELETTRICI ELECTRICAL APPLIANCES | 186 |



Molla per ghiaccio

| Ice cube tongs | Cod. | L cm | Box |
|----------------|---------------|------|-----|
| | 010400 | 18 | 12 |



Molla frutta

Design by Michele Capuani

| Fruit tongs | Cod. | L cm | Box |
|-------------|---------------|------|-----|
| | 014500 | 30 | 12 |
| | 014515 | 15 | 12 |
| | 014523 | 23,5 | 12 |
| | 014540 | 40 | 12 |



Molla per ghiaccio

| Ice cube tongs | Cod. | L cm | Box |
|----------------|---------------|------|-----|
| | 011100 | 20 | 12 |



Molla frutta 40°

Design by Michele Capuani

| 40° fruit tongs | Cod. | L cm | Box |
|-----------------|---------------|------|-----|
| | 014600 | 30 | 12 |
| | 014615 | 15 | 12 |
| | 014623 | 23,5 | 12 |



Molla per ghiaccio

| Ice cube tongs | Cod. | L cm | Box |
|----------------|---------------|------|-----|
| | 011500 | 16 | 12 |



Molla frutta in nylon & fiberglass

Design by Michele Capuani

| Nylon & fiberglass fruit tongs | Cod. | L cm | Box |
|--------------------------------|-----------------|------|-----|
| | 01833000 | 30 | 12 |



Tappo versatore con silicone Design-Pourer

Design by Marco Valente

| Design-Pourer silicone gear | Cod. |
|-----------------------------|---------------|
| | 050800 |



ADATTO A
SUITABLE FOR
Ø mm 17,5 > 18



Tappo versatore con silicone Tech-Pourer

Design by Marco Valente

| Tech-Pourer silicone gear | Cod. |
|---------------------------|----------------|
| | 0509004 |



ADATTO A
SUITABLE FOR
Ø mm 17,5 > 18



Tappo versatore con silicone Tech-Pourer

Design by Marco Valente

| Tech-Pourer silicone gear | Cod. |
|---------------------------|----------------|
| | 0510004 |



ADATTO A
SUITABLE FOR
Ø mm 17,5 > 18



Tappo versatore con silicone Tech-Pourer

Design by Marco Valente

| Tech-Pourer silicone gear | Cod. |
|---------------------------|----------------|
| | 0511004 |



ADATTO A
SUITABLE FOR
Ø mm 17,5 > 18



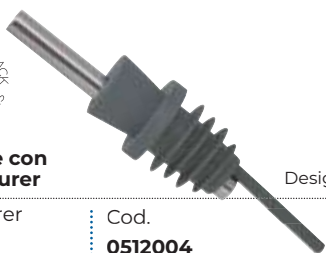

ADATTO A
SUITABLE FOR
Ø mm 17,5 > 18



Design by Marco Valente

Tappo versatore con silicone Soft-Pourer

Pourer Soft-Pourer

Cod. 0512004



NEW

ADATTO A
SUITABLE FOR
Ø mm 17,5 > 18

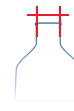

Tappo versatore dosatore inox con cappuccio

Measuring stainless steel pourer with closure cap

Cod. 0532552

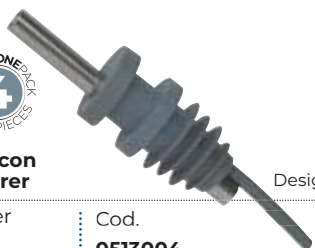

ADATTO A
SUITABLE FOR
Ø mm 17,5 > 18



Design by Marco Valente

Tappo versatore con silicone Soft-Pourer

Pourer Soft-Pourer

Cod. 0513004



ADATTO A
SUITABLE FOR
Ø mm 17,5 > 18



Tappo versatore dosatore inox con chiusura

Measuring stainless steel pourer with lid

Cod. 05325012



ADATTO A
SUITABLE FOR
Ø mm 17,5 > 18

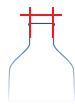

Design by Marco Valente

Tappo versatore per vino con chiusura

Closable wine-pouring stopper

Cod. 051800

Box 18



Tappo versatore continuo

Design by Marco Valente

Continuous pourer

Cod. 05350112
05350312
05350412
05350612

Col. 4
 4
 4
 4



ADATTO A
SUITABLE FOR
Ø mm 17,5 > 18



Tappo versatore dosatore in acciaio inox

Measuring stainless steel pourer

Cod. 05321012



Tappo versatore metrico

Metric pourer

Cod. 0540153
0540203
0540253
0540303
0540353
0540403
0540503

ml 15 20 25 30 35 40 50
Col.



BPour, tester per dosaggi

BPour, pour check

Cod. 053290 Ø cm 10,5 H cm 16,5





Cod. 0533002

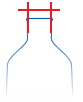

Cod. 0533006

ADATTO A
SUITABLE FOR
Ø mm 18,5 > 21**Tappo versatore SteadySpout 2.0**

SteadySpout 2.0 pourer

Cod.

0533002

Cod. 0533006

0533006

STEADYSPOUT^{2.0}

THE EVOLUTION OF THE METAL POURER

Con SteadySpout avrai un versaggio sempre costante a 157BPM, l'unità di misura usata dai bartender per calibrare perfettamente la quantità di liquido nella preparazione dei cocktail.

INALTERABILE

La speciale plastica dotata di "memoria" torna alla forma originale con un passaggio in lavastoviglie.

ROBUSTO

Composto da 2 soli pezzi invece che 4.

Più solido e più resistente all'usura.

Maggiore durata nel tempo rispetto ai diretti concorrenti.

PRECISO

Velocità d'uscita del liquido garantita dalla presa d'aria. Nessuna goccia sia all'inizio che alla fine del versaggio. Ideale per la tecnica del jumping.

UNIVERSALE

Disegno e materiale delle lamelle offrono massima presa e inserimento/disinserimento facile e veloce. Il doppio modulo di diametro lo rende adatto a bottiglie con collo da Ø18 a Ø21,5 mm.

BREVETTATO

Concepito, studiato e interamente progettato dall'ufficio tecnico di PIAZZA. 100% Made in Italy.

CARATTERISTICHE TECNICHE

- Cannuccia in acciaio inox 18/10 AISI 304 con lavorazione al laser
- Diametro, rastrematura e inclinazione della cannuccia perfettamente calibrati sia all'interno che all'esterno
- Lavabile in lavastoviglie

TECHNICAL SPECIFICATIONS

- Reed in AISI 304 18/10 laser processed stainless steel
- Perfectly calibrated diameter, tapering and inclination of the reed, both inside and outside
- Dishwasher friendly

With SteadySpout, the rate of pouring is always constant at 157BPM, the unit of measurement used by bartenders to perfectly calibrate the quantity of liquid in the preparation of cocktails.

NEVER CHANGES

Special plastic with "memory" returns to the original shape simply by putting it through the dishwasher.

STURDY

Composed of only 2 pieces rather than 4.

Sturdier and more resistant to wear and tear.

Longer duration compared to the other competitors.

ACCURATE

Pouring speed of the liquid guaranteed by the air intake. No spills either at the start or end of the pouring.

Perfect for the jumping technique.

UNIVERSAL

Design and material of the reed valves offer maximum grip and an easy and fast plugging/unplugging.

The double diameter module makes it suitable for bottles with necks of diameters from Ø18 to Ø21.5 mm.

PATENTED

Conceived, developed and entirely designed by PIAZZA's technical office. Entirely manufactured in Italy



FEEL THE BEAT
MIX THE DRINKS



SCOPRI COME
LO PRODUCIAMO
DISCOVER HOW
WE MANUFACTURE IT



Riga limone

Lemon grater

Cod.
163400

L cm
14



Decora limone

Lemon decorator

Cod.
163500

L cm
14,5



Sbuccia arancia

Orange peeler

Cod.
163700

L cm
14,5



Scavino 2 coppe

Melon baller-double

Cod.
164100

L cm
16,5



Scavino 1 coppa

Melon baller

Cod.
164200

L cm
13



Set decorazione cocktail - 7 pezzi

Cocktail decoration set
7 pieces

Cod.
8151-9100G7001



COLTELLO
KNIFE



SBUCCIA ARANCIA
ORANGE PEELER



SCAVINO MELONE
MELON BALLER



COLTELLO PER PELARE
PEELING KNIFE



LEVATORE SOLO
APPLE CORER



RIGA LIMONE
LEMON GRATER



DECORA LIMONE
LEMON DECORATOR



Cucchiaino per bibita

Beverage spoon

Cod.
310207

L cm T mm Box
20 3 12



Cucchiaino per bibita

Beverage spoon

Cod.
321900

L cm Box
20 6





Vassoio rettangolare per bar in acciaio

Rectangular steel bar tray

| Cod. | L x W cm |
|---------------|-----------|
| 360025 | 25 x 19,5 |
| 360029 | 29 x 22 |
| 360034 | 34 x 27 |
| 360040 | 40 x 32 |
| 360046 | 46 x 35 |
| 360052 | 52 x 38 |
| 360060 | 60 x 45 |



Vassoio rettangolare per bar in acciaio con maniglie

Rectangular steel bar tray with handles

| Cod. | L x W cm |
|---------------|----------|
| 360240 | 40 x 32 |
| 360246 | 46 x 35 |
| 360252 | 52 x 38 |
| 360260 | 60 x 45 |



Vassoio ovale per bar in acciaio

Oval steel bar tray

| Cod. | L x W cm |
|---------------|----------|
| 360419 | 19 x 14 |
| 360423 | 23 x 18 |
| 360426 | 26 x 20 |



Vassoio rettangolare laminato antiscivolo

Rectangular laminated tray with non slip treatment

| Cod. | L x W cm | Box |
|---------------|-------------------------|-----|
| 361000 | 37 x 53 EN | 12 |
| 361100 | 32,5 x 53 GN 1/1 | 12 |
| 361200 | 36 x 46 | 12 |
| 361300 | 32 x 44 | 12 |
| 361400 | 33 x 43 | 12 |
| 361500 | 24,5 x 34 | 12 |
| 361600 | 28 x 20 | 12 |



Vassoio rettangolare laminato

Rectangular laminated tray

| Cod. | L x W cm | Box |
|---------------|-------------------------|-----|
| 361001 | 37 x 53 EN | 12 |
| 361101 | 32,5 x 53 GN 1/1 | 12 |
| 361201 | 36 x 46 | 12 |
| 361501 | 24,5 x 34 | 12 |



Vassoio trapezoidale laminato antiscivolo

Trapezoidal laminated tray with non slip treatment

| Cod. | L x W cm | Box |
|---------------|----------|-----|
| 362500 | 36 x 52 | 12 |



Vassoio trapezoidale laminato

Trapezoidal laminated tray

| Cod. | L x W cm | Box |
|---------------|----------|-----|
| 362501 | 36 x 52 | 12 |



Vassoio trapezoidale laminato antiscivolo

Trapezoidal laminat. tray with non slip treatment

| Cod. | L x W cm | Box |
|---------------|----------|-----|
| 362600 | 33 x 47 | 12 |





Vassoio ovale laminato antiscivolo

| Oval laminated tray with non slip treatment | Cod. | L x W cm | Box |
|---|---------------|-----------|-----|
| | 363000 | 27 x 38 | 12 |
| | 363100 | 20 x 26,5 | 12 |



Vassoio rettangolare Rubberform antiscivolo

| Rectangular Rubberform tray with non slip treatment | Cod. | L x W cm | Box |
|---|---------------|---------------------------|-----|
| | 366001 | 37 x 53 EN | 12 |
| | 366101 | 32,5 x 53 GN 1/1 | 12 |
| | 366201 | 36 x 46 | 12 |
| | 366301 | 33 x 43 | 12 |
| | 366401 | 20 x 28 | 12 |
| | 366501 | 26,5 x 32,5 GN 1/2 | 12 |



Vassoio rotondo laminato antiscivolo

| Round laminated tray with non slip treatment | Cod. | Ø cm | Box |
|--|---------------|------|-----|
| | 363500 | 43 | 12 |
| | 363600 | 38 | 12 |
| | 363700 | 32 | 12 |



Vassoio ovale Rubberform antiscivolo

| Oval Rubberform tray with non slip treatment | Cod. | L x W cm | Box |
|--|---------------|-----------|-----|
| | 367001 | 21 x 29 | 12 |
| | 367101 | 20 x 26,5 | 12 |
| | 367301 | 44 x 58 | 12 |



Vassoio rettangolare KAU Polyform antiscivolo

| Rectangular KAU Polyform tray with non slip treatment | Cod. | L x W cm | Box |
|---|---------------|-------------------------|-----|
| | 364000 | 37 x 53 EN | 12 |
| | 364100 | 32,5 x 53 GN 1/1 | 12 |



Vassoio rotondo Rubberform antiscivolo

| Round Rubberform tray with non slip treatment | Cod. | Ø cm | Box |
|---|---------------|------|-----|
| | 367501 | 43 | 12 |
| | 367601 | 38 | 12 |
| | 367701 | 32 | 12 |



Vassoio rotondo KAU Polyform antiscivolo

| Round KAU Polyform tray with non slip treatment | Cod. | Ø cm | Box |
|---|---------------|------|-----|
| | 365500 | 36 | 12 |



Vassoio rettangolare in poliestere rinforzato

| Oval reinforced tray in polyester | Cod. | L x W cm | Box |
|-----------------------------------|---------------|---------------------------|-----|
| | 368000 | 37 x 53 EN | 12 |
| | 368300 | 26,5 x 32,5 GN 1/2 | 12 |



Vassoio ovale in poliestere rinforzato

| Oval reinforced tray in polyester | Cod. | L x W cm | Box |
|-----------------------------------|---------------|----------|-----|
| | 368500 | 21 x 29 | 12 |





Lattiera

Milk jug

| Cod. | ml |
|---------------|------|
| 460503 | 250 |
| 460504 | 350 |
| 460506 | 500 |
| 460509 | 750 |
| 460512 | 1000 |



Spargicacao

Cocoa sprinkler

| Cod. | H cm |
|---------------|------|
| 470500 | 9 |



Mestolino per ciliegie

Cherry ladle

| Cod. | Ø cm | L cm |
|---------------|------|------|
| 430900 | 4 | 23 |



Mestolino per ciliegie con fori

Cherry ladle with holes

| Cod. | Ø cm | L cm |
|---------------|------|------|
| 431000 | 4 | 23 |



Mestolino per ciliegie manico lungo

Cherry ladle

| Cod. | Ø cm | L cm |
|---------------|------|------|
| 431100 | 4 | 28 |



Mestolino per ciliegie

Cherry ladle

| Cod. | Ø cm | L cm |
|---------------|------|------|
| 431200 | 4 | 21,5 |



Mestolino per ciliegie con fori

Cherry ladle with holes

| Cod. | Ø cm | L cm |
|---------------|------|------|
| 431300 | 4 | 21,5 |



Spremiagrumi

Citrus juicer

| Cod. | Ø cm | cl |
|---------------|------|----|
| 470700 | 13 | 50 |





Jigger

| | | |
|---------------|---------------|-------------------------|
| Double jigger | Cod. | ml |
| | 470812 | scaled 20-30-50 30 x 60 |
| | 470813 | 30 x 90 |
| | 470823 | 60 x 90 |



Cucchiaino per cocktail

| | | |
|----------------|---------------|------|
| Cocktail spoon | Cod. | L cm |
| | 471200 | 15 |



Colino per cocktail

| | | |
|-------------------|---------------|------|
| Cocktail strainer | Cod. | L cm |
| | 470900 | 16 |



Cucchiaino per bibita triangolare

| | | |
|-----------------------------|----------------|------|
| Triangular long drink spoon | Cod. | L cm |
| | 4715246 | 24 |



Agitatore

| | | |
|----------------|---------------|------|
| Stirring spoon | Cod. | L cm |
| | 471000 | 24 |



Portacucchiaini

| | | | |
|-------------------|---------------|------|------|
| Moka spoon holder | Cod. | Ø cm | H cm |
| | 472100 | 7 | 8 |



Cucchiaino per ghiaccio

| | | |
|-----------|---------------|------|
| Ice spoon | Cod. | L cm |
| | 471100 | 24 |



Vaschetta lavaggio dosatori gelato

| | | | |
|---------------|---------------|------|------|
| Rinsing basin | Cod. | Ø cm | H cm |
| | 472200 | 8,5 | 11 |





Levacapsule

Bottle-opener

Cod. L cm
472700 14



Spremilimone

Lemon slice squeezer

Cod.
4728002



Spremilimone

Lemon slice squeezer

Cod.
4729002

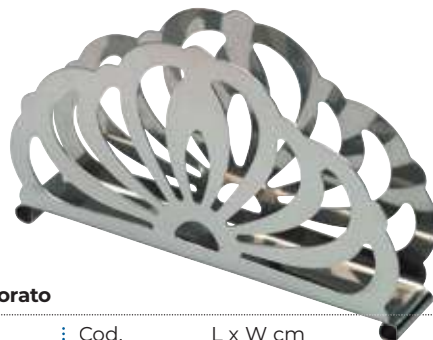

Portatovaglioli traforato

Napkin-holder

Cod. L x W cm
473000 13,5 x 7

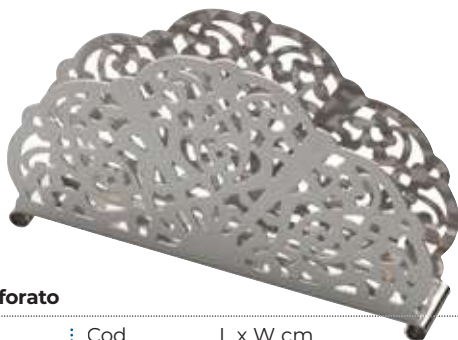

Portatovaglioli traforato

Napkin-holder

Cod. L x W cm
473100 13,5 x 7



Portatovaglioli con base teak

Napkin stand

Cod. L x W cm
473200 14 x 8



Cuocithé a cucchiaino

Spoon tea infuser

Cod. L cm
473300 15



Cuocithé a campana

Bell tea boiler

Cod.
473400



Sottobicchiere

Coaster

Cod. Ø cm
474209 9
474210 10



Cod. 474213



Sottobottiglia

Coaster

Cod. Ø cm
474213 13







Boston shaker in acciaio

| Stainless steel boston shaker | Cod. | Col. | ml |
|-------------------------------|---------------|------|-----|
| | 474690 | ● | 900 |
| | 474700 | ● | 900 |
| | 474703 | ● | 900 |



Boston shaker in acciaio colorato

| Coloured stainless steel boston shaker | Cod. | Col. | ml |
|--|---------------|------|-----|
| | 474750 | ● | 900 |
| | 474753 | ● | 900 |



Boston shaker in acciaio

| Stainless steel boston shaker | Cod. | ml |
|-------------------------------|---------------|-----|
| | 474850 | 500 |



Boston shaker in acciaio a due pezzi

| 2-parts stainless steel boston shaker | Cod. |
|---------------------------------------|---------------|
| | 474890 |





Colino per cocktail

Cocktail strainer Cod. L cm
470900 16



Bicchiere vetro per boston shaker

Glass for boston shaker Cod. ml Box
474900 474 6



Colino per cocktail

Cocktail strainer Cod. L cm
475600 16



Bicchiere vetro per boston shaker temperato

Tempered glass for boston shaker Cod. ml Box
474901 414 6



Colino per cocktail in acciaio con manico vuoto

Steel cocktail strainer with hollow handle Cod. L cm
475601 16



Bicchiere vetro per boston shaker graduato

Scaled glass for boston shaker Cod. ml Box
474902 474 6



Colino per cocktail in acciaio color grafite

Black steel cocktail strainer Cod. L cm
475605 16



Bicchiere vetro "beverage" per boston shaker

"Beverage" glass for boston shaker Cod. ml Box
474904 414 6





Japmixing glass con beccuccio

Japmixing glass with lip Cod. ml
474906 650



Mixing glass double wall in acciaio con beccuccio

Stainless steel double wall mixing glass with lip Cod. ml
474910 535



Bicchieri Juice per cocktail

Juice cocktail glass Cod. ml Box
474915 421 12



Bicchieri High Ball per cocktail

High Ball cocktail glasses Cod. ml Box
474916 361 12
474920 361 12



Bicchieri Rocks, Shooter e Shot Rocks per cocktail

Rocks, Shooter and Shot Rocks cocktail glasses Cod. ml Box
474917 269 12
474918 137 12
474919 37 12



Shaker a 2 pezzi lucido

2-parts polished shaker Cod. ml
475055 550





Shaker a 2 pezzi in acciaio

2-parts steel shaker

Cod. **475060** ml 600



Shaker a 2 pezzi in acciaio ramato

2-parts copper plated shaker

Cod. **475160** ml 600



Shaker a 2 pezzi satinato

2-parts brushed shaker

Cod. **477080** ml 800



Shaker a 3 pezzi in acciaio

3-parts steel shaker

Cod. **475225** ml 250
475250 ml 500
475275 ml 750



Shaker a 3 pezzi lucido

3-parts polished shaker

Cod. **475175** ml 750



Shaker a 2 pezzi in ottone

2-parts brass shaker

Cod. **475440** ml 400



Shaker a 2 pezzi in rame

2-parts copper shaker

Cod. **477260** ml 600



Shaker a 2 pezzi in acciaio color grafite

2-parts steel black shaker

Cod. **477160** ml 600





Jigger in acciaio Japan style

Stainless steel jigger Japan style

| Cod. | ml | Col. |
|---------------|---------|------|
| 475542 | 25 x 50 | ● |
| 475544 | 25 x 50 | ● |



Jigger Japan style

Jigger Japan style

| Cod. | ml | Col. |
|---------------|---------|------|
| 475546 | 30 x 50 | ● |



Jigger in acciaio Japan style

Stainless steel jigger Japan style

| Cod. | ml |
|---------------|---------|
| 475535 | 20 x 40 |
| 475543 | 25 x 50 |
| 475550 | 15 x 30 |
| 475555 | 30 x 60 |
| 475560 | 30 x 45 |



Jigger in acciaio slim

Stainless steel jigger slim

| Cod. | ml |
|---------------|---------|
| 475570 | 30 x 45 |
| 475575 | 25 x 50 |
| 475580 | 30 x 60 |



Jigger in acciaio

Steel double jigger

| Cod. | ozs |
|---------------|-------------|
| 475545 | 3/4 x 1,1/2 |



Jigger in acciaio

Stainless steel jigger

| Cod. | ml | Col. |
|---------------|---------|------|
| 475590 | 30 x 60 | ● |
| 475591 | 30 x 60 | ● |
| 475592 | 30 x 60 | ● |





Jigger in acciaio
Mixing Tin style

Stainless steel jigger
Mixing Tin style

Cod. 475500 ml 75



Jigger in acciaio

Stainless steel jigger

Cod. 475565 ml 75



Jigger in plastica

Plastic jigger

Cod. 475548 ml 20 x 40
475549 ml 10 x 20



Jigger

Double jigger

Cod. 470812 scaled 20-30-50 ozs 1-2
470813 1-3
470823 2-3



Set 8 pezzi Bartending Essentials

Bartending Essential
Pack 8 pcs.

Cod. 665500



Set 5 pezzi Bartending Black Edition

Bartending Black
Edition Pack 5 pcs.

Cod. 665600



- 0533002 TAPPO VERSATORE STEADYSPOUT STEADYSPOUT POURER (2 PZ.)
- 470900 COLINO COCKTAIL COCKTAIL STRAINER
- 474690 BOSTON SHAKER IN ACCIAIO STAINLESS STEEL BOSTON SHAKER
- 475545 JIGGER IN ACCIAIO STEEL DOUBLE JIGGER 3/4 x 1.1/2 OZS
- 475828 CUCCHIAIO MISCELAT. CON PESTELLO MIXING SPOON WITH STUD
- 510200 PESTELLO RIGATO IN POLIPROPILENE POLYPROP. RIBBED PESTLE
- TUMBLER ALTO IN HIGH TUMBLER

- 053212 TAPPO VERSATORE POURER
- 475542 JIGGER IN ACCIAIO STEEL DOUBLE JIGGER 25/50 ML
- 475605 COLINO COCKTAIL COCKTAIL STRAINER
- 475832 CUCCHIAIO MISCEL. CON FORCHETTA MIXING SPOON WITH FORK
- 477160 COCKTAIL SHAKER IN ACCIAIO STEEL COCKTAIL SHAKER 600 ML



Sessola in plastica

| Plastic ice scoop | Cod. | ml | Box |
|-------------------|---------------|-----|-----|
| | 506800 | 180 | 6 |
| | 506801 | 360 | 6 |
| | 506802 | 720 | 6 |



Pestello in polipropilene liscio

| Smooth polypropylene pestle | Cod. | L cm | Col. | Box |
|-----------------------------|---------------|------|------|-----|
| | 510000 | 21 | ● | 6 |
| | 510002 | 21 | ○ | 6 |



Cod. 510000



Pestello in polipropilene rigato

| Ribbed polypropylene pestle | Cod. | L cm | Col. | Box |
|-----------------------------|---------------|------|------|-----|
| | 510200 | 21,5 | ● | 6 |
| | 510202 | 21,5 | ○ | 6 |



Cod. 510200



Pestello in polipropilene nero

| Black polypropylene pestle | Cod. | L cm |
|----------------------------|---------------|------|
| | 510300 | 21,5 |



NEW

Pestello in acacia

| Pestle | Cod. | L cm |
|--------|---------------|------|
| | 503300 | 19 |
| | 503301 | 25 |



Sessola in polipropilene

| Polypropylene ice scoop | Cod. | ml | Box |
|-------------------------|---------------|-----|-----|
| | 506811 | 360 | 6 |



Rompighiaccio manuale in plastica finitura cromo

| Chrome-finished plastic manual ice-breaker | Cod. |
|--|---------------|
| | 503900 |



Rompighiaccio a 6 punte

| 6-point ice-breaker | Cod. |
|---------------------|---------------|
| | 504000 |

- **Rompighiaccio professionale ideato per la preparazione di Caipirinhas, Mojitos e frozen vari, idoneo inoltre per guarnire piatti di pesce fresco**
Professional ice-breaker designed for preparing Caipirinhas, Mojitos and various frozen drinks, also for garnishing fresh fish dishes
- **Robusto e veloce, consente di preparare ghiaccio spezzato con una produttività di 2 kg al minuto**
Fast and strong, it lets you prepare chopped ice at a rate of 2 kg a minute
- **Corpo in lega leggera e contenitore in acciaio inox con motore ventilato con potenza di 150 watt**
Light alloy body and stainless steel bucket with 150 watt fan motor
- **Approvato CE**
CE approved



Rompighiaccio verticale in acciaio

| Steel vertical ice-breaker | Cod. | Volt |
|----------------------------|---------------|------|
| | 550700 | 220 |





Cucchiaino miscelatore in acciaio con tappo rosso

| Steel mixing spoon | Cod. | L cm | Box |
|--------------------|---------------|------|-----|
| | 475725 | 25 | 12 |
| | 475728 | 28 | 12 |

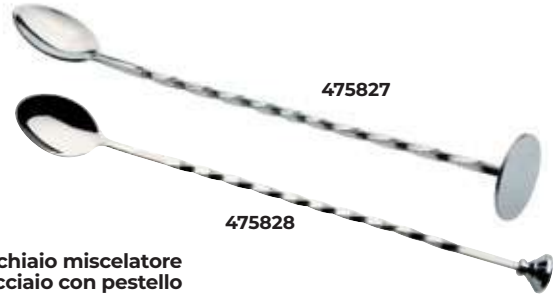

Cucchiaino miscelatore in acciaio con pestello

| Steel mixing spoon with stud | Cod. | L cm | Box |
|------------------------------|---------------|------|-----|
| | 475827 | 27 | 12 |
| | 475828 | 28 | 12 |



Cucchiaino miscelatore in acciaio a goccia

| Drop steel mixing spoon | Cod. | L cm | Box |
|-------------------------|---------------|------|-----|
| | 475800 | 25 | 6 |
| | 475805 | 30 | 6 |
| | 475810 | 40 | 6 |
| | 475815 | 50 | 6 |



Cucchiaino miscelatore in acciaio con forchetta

| Steel mixing spoon with fork | Cod. | L cm | Col. | Box |
|------------------------------|---------------|------|------|-----|
| | 475830 | 30 | ● | 6 |
| | 475831 | 30 | ● | 6 |
| | 475832 | 30 | ● | 6 |



Cucchiaino miscelatore in acciaio coppa ovale

| Oval cup steel mixing spoon | Cod. | L cm | Box |
|-----------------------------|---------------|------|-----|
| | 475930 | 30 | 12 |

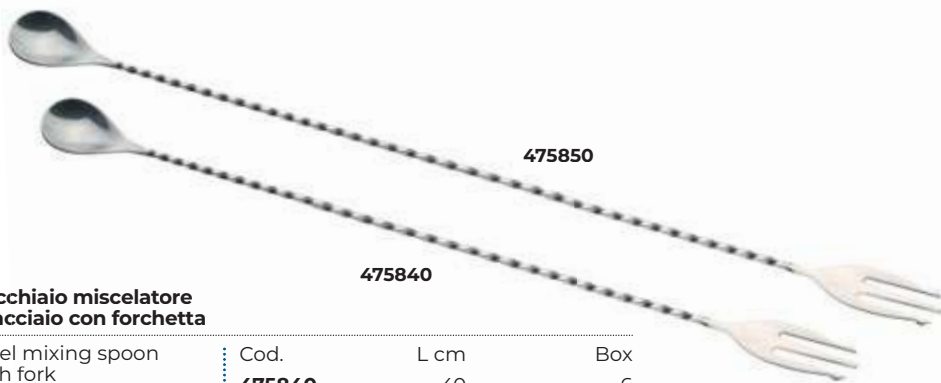

Cucchiaino miscelatore in acciaio con forchetta

| Steel mixing spoon with fork | Cod. | L cm | Box |
|------------------------------|---------------|------|-----|
| | 475840 | 40 | 6 |
| | 475850 | 50 | 6 |





Julep mug in acciaio inox

Stainless steel julep mug : Cod. ml
4781482 380



Moscow Mule mug bombata in acciaio dorato e martellato

Golden plated hammered Moscow Mule mug : Cod. ml
478302 500



Moscow Mule mug bombata in acciaio ramato e martellato

Copper plated hammered Moscow Mule mug : Cod. ml
4783002 470



Moscow Mule mug bombata in acciaio ramato

Copper plated Moscow Mule mug : Cod. ml
4783052 470



Mug in acciaio ramato

Copper plated mug : Cod. ml
4783152 470



Beer mug in acciaio ramato, effetto anticato

Copper plated beer mug antique : Cod. ml
4783252 500



Beer mug in acciaio ramato, effetto anticato

Copper plated beer mug antique : Cod. ml
4783302 500
4783352 400





**Mug ananas
in acciaio ramato**

Copper plated
pineapple mug

Cod. 478321 ml 550



**Mug zucca
in acciaio ramato**

St. steel copper plated
gourd mug

Cod. 478351 ml 350



Mug in acciaio

Stainless steel mug

Cod. 478350 ml 700



**Mug zucca
in acciaio ramato**

St. steel copper plated
pumpkin mug

Cod. 478352 ml 650



478340

478342

**Mug pera
in acciaio**

Stainless steel
pear mug

| | | |
|--------|-----|------|
| Cod. | ml | Col. |
| 478340 | 425 | ● |
| 478342 | 425 | ● |



**Wine glass in acciaio
color grafite**

Black stainless steel
wine glass

Cod. 4783452 ml 550







Dash bottle "Old fashioned"

Dash bottle
"Old fashioned"

Cod. ml
479101 100
479190 Tappo versatore/Pourer for dash bottle



TAPPO VERSATORE NON INCLUSO
POURER NOT INCLUDED



Dash bottle

Dash bottle

Cod. ml
479110 100
479190 Tappo versatore/Pourer for dash bottle



TAPPO VERSATORE NON INCLUSO
POURER NOT INCLUDED



Vaporizzatore cocktail in vetro "Old fashioned"

Cocktail atomizer
"Old fashioned"

Cod. ml
479121 100



IMBUTO DI RIEMPIMENTO INCLUSO NELLA CONFEZIONE
FUNNEL INCLUDED IN THE PACKAGE



Vaporizzatore cocktail cromato

Chromed cocktail
atomizer

Cod. ml
479130 65



IMBUTO DI RIEMPIMENTO INCLUSO NELLA CONFEZIONE
FUNNEL INCLUDED IN THE PACKAGE



Kit 4 vaporizzatori cocktail in vetro 2 cilindrici + 2 quadrati

Pack 4 cocktail atomizers
2 cylindrical + 2 square

Cod. ml
479150 33



IMBUTO DI RIEMPIMENTO INCLUSO NELLA CONFEZIONE
FUNNEL INCLUDED IN THE PACKAGE



Spremilimone nero

Lemon squeezer black

Cod.
476402



Spremilimone/spremilime nero e rosso

Lemon/lime squeezer
black and red

Cod.
476412





Coltello per agrumi

| | | | |
|--------------------|---------------|------|-----|
| Citrus fruit knife | Cod. | L cm | Box |
| | 476600 | 21 | 12 |



Apribottiglie piatto in acciaio

| | | | |
|--------------------------|---------------|------|-----|
| Flat steel bottle-opener | Cod. | L cm | Box |
| | 476800 | 18 | 12 |



Apribottiglie professionale in acciaio satinato

| | |
|---|---------------|
| Professional satin-finish steel bottle-opener | Cod. |
| | 476900 |



Pinza apribottiglie in acciaio

| | |
|------------------------|---------------|
| Steel champagne opener | Cod. |
| | 477300 |



Apribottiglie da muro in acciaio

| | | |
|----------------------------------|---------------|-----|
| Steel wall-mounted bottle-opener | Cod. | Box |
| | 477400 | 12 |



Apribottiglie da muro

| | |
|----------------------------|---------------|
| Wall-mounted bottle-opener | Cod. |
| | 477500 |



Spirale di ricambio per apribottiglie muro e tavolo

| | | |
|---------------------------------------|---------------|-----|
| Spare screw for table/wall corkscrews | Cod. | Box |
| | 477550 | 12 |



Sessola in acciaio

| | | | |
|-------------------------|---------------|------|-----|
| Steel all purpose scoop | Cod. | L cm | Box |
| | 477900 | 24 | 12 |



Secchiello ghiaccio in acciaio

| | | | |
|------------------|---------------|------|------|
| Steel ice bucket | Cod. | Ø cm | H cm |
| | 478014 | 14 | 16 |





Secchiello vino in acciaio

Steel wine bucket

| Cod. | Ø cm | H cm |
|---------------|------|------|
| 478421 | 21 | 21 |



Secchiello vino in acciaio

Steel wine bucket

| Cod. | Ø cm | H cm |
|---------------|------|------|
| 478624 | 24 | 26 |



Colonna per secchiello in acciaio

Stand for steel bucket

| Cod. | Ø cm | H cm |
|---------------|------|------|
| 478525 | 25 | 65 |



PER FOR
478421



Colonna a filo in acciaio per secchiello vino

Steel wire bucket stand

| Cod. | Ø cm | H cm |
|---------------|------|------|
| 478760 | 24 | 60 |



PER FOR
478624



Spumantiera in acciaio

Steel champagne bowl

| Cod. | Ø cm |
|---------------|------|
| 479400 | 40 |





Portatovaglioli in acciaio

| Napkin holder | Cod. | H cm | Box |
|---------------|---------------|------|-----|
| | 479600 | 18 | 6 |
| | 479601 | 10 | 6 |



Portacondimenti plastica con 3 contenitori (L)

| Black plastic cruet with 3 containers (L) | Cod. | L x W cm | H cm |
|---|---------------|----------|------|
| | 502000 | 49 x 15 | 9 |



Portacondimenti in acciaio con 3 contenitori

| Steel cruet with 3 containers | Cod. | L x W cm | H cm |
|-------------------------------|---------------|----------|------|
| | 479803 | 45 x 15 | 9 |



Portacondimenti plastica con 4 contenitori (M)

| Black plastic cruet with 4 containers (M) | Cod. | L x W cm | H cm |
|---|---------------|----------|------|
| | 502100 | 49 x 15 | 9 |



Portacondimenti in acciaio con 4 contenitori

| Steel cruet with 4 containers | Cod. | L x W cm | H cm |
|-------------------------------|---------------|----------|------|
| | 479804 | 30 x 14 | 9 |



Portacondimenti plastica con 6 contenitori (S)

| Black plastic cruet with 6 containers (S) | Cod. | L x W cm | H cm |
|---|---------------|----------|------|
| | 502300 | 49 x 15 | 9 |



Portacondimenti in acciaio con 6 contenitori

| Steel cruet with 6 containers | Cod. | L x W cm | H cm |
|-------------------------------|---------------|----------|------|
| | 479806 | 45 x 15 | 9 |



Contenitore sostitutivo in plastica

| Spare plastic container | Cod. | L x W cm | H cm | Box |
|-------------------------|---------------|-------------|------|-----|
| | 502400 | 7 x 14 (S) | 7 | 12 |
| | 502401 | 14 x 14 (L) | 7 | 12 |
| | 502402 | 11 x 14 (M) | 7 | 12 |





Speed racks in acciaio

| Steel speed racks | Cod. | L cm |
|-------------------|---------------|------|
| | 479900 | 56 |
| | 479901 | 82 |
| | 479902 | 107 |

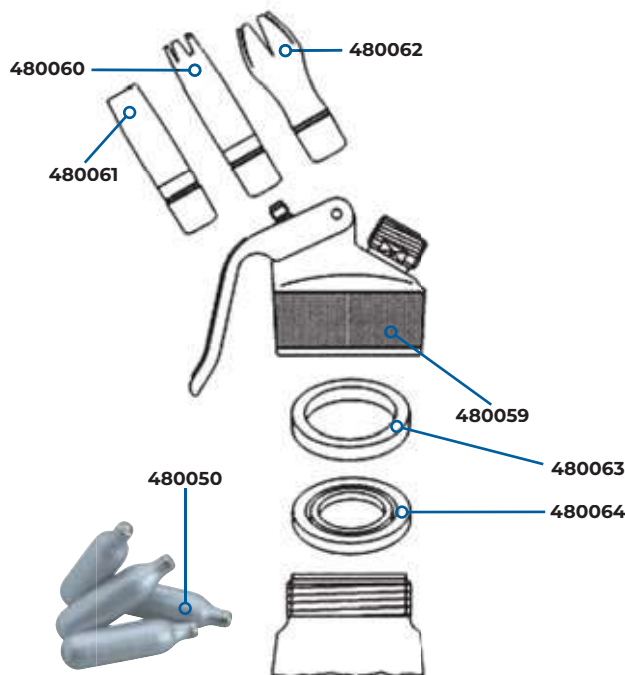

Ricambi per sifone panna montata

Spare parts for whipped cream syphon

| Cod. | Description |
|---------------|---|
| 480050 | Ricarica/Refill (10 pz/pcs) |
| 480059 | Testata completa in metallo/Head complete metal |
| 480060 | Decorat. di ricambio rosso/Round shape nozzle red |
| 480061 | Decorat. di ricambio piatto/Plain shape nozzle |
| 480062 | Decorat. di ricambio tulipano/Tulip shape nozzle |
| 480063 | Guarnizione per testata rossa/Head gasket red |
| 480064 | Guarnizione per testata grigia/Head gasket grey |



Sifone termico per panna montata

| Thermos syphon for whipped cream | Cod. | Lt |
|----------------------------------|---------------|-----|
| | 480005 | 0,5 |



Raccogliatrice in alluminio

| Aluminum crumb collector | Cod. | Box |
|--------------------------|---------------|-----|
| | 490108 | 24 |



Sifone per panna montata

| Whipped cream syphon | Cod. | Lt |
|----------------------|---------------|-----|
| | 480105 | 0,5 |
| | 480110 | 1 |



Barra ordinazioni in alluminio

| Aluminum order rack | Cod. | L cm |
|---------------------|---------------|------|
| | 490000 | 30 |
| | 490001 | 45 |
| | 490002 | 61 |
| | 490003 | 91 |
| | 490004 | 122 |





Versus completo da 0,5 lt

| Complete versus 0.5 lt | Cod. | Col. | cl | Box |
|------------------------|--------|------|----|-----|
| | 500000 | | 50 | 12 |



Versus completo da 1 lt

| Complete versus 1 lt | Cod. | Col. | cl | Box |
|----------------------|--------|------|-----|-----|
| | 500200 | | 100 | 12 |
| | 500201 | | 100 | 12 |
| | 500203 | | 100 | 12 |
| | 500204 | | 100 | 12 |
| | 500206 | | 100 | 12 |



Versus riserva da 0,5 lt
Colori assortiti

| Spare versus 0.5 lt (various colours) | Cod. | Col. | cl | Box |
|---------------------------------------|--------|------|----|-----|
| | 500100 | | 50 | 12 |



Versus riserva da 1 lt
Colori assortiti

| Spare versus 1 lt (various colours) | Cod. | Col. | cl | Box |
|-------------------------------------|--------|------|-----|-----|
| | 500300 | | 100 | 12 |



versus

Design by Michele Capuani

Una gamma completa di versatori, risultato di un progetto studiato fin nei minimi particolari, in grado di offrire ai professionisti del settore Bar prestazioni ineguagliabili. Materiali di prim'ordine, caratteristiche tecniche all'avanguardia, forme progettate ergonomicamente, dettagli costruttivi analizzati fin nei minimi particolari, tutto è stato studiato per garantire non solo prestazioni "al top" in ogni situazione, ma anche per offrire il massimo in termini di comodità, praticità, facilità d'uso, igienicità.

A complete range of pourers, the result of a detailed project, capable of offering Bar professionals unmatched performance. Top grade materials, advanced technology, ergonomic design, construction details that have been carefully studied right down to the smallest details: all aimed at guaranteeing not just "top" performance in all situations, but also max comfort, practicality, ease of use and hygiene.



Chiodibeccuccio a tenuta per garantire la massima igienicità nell'utilizzo.

Spout seal to guarantee max hygiene during use.

Beccuccio versatore in colori assortiti, studiato per offrire un flusso del liquido costante ed omogeneo. Il suo ancoraggio al collo di versus avviene attraverso un giro completo di filettatura per una tenuta ottimale in ogni condizione d'uso.

Pouring spout in various colours, designed to get a constant, even flow. Fixed to the neck of the versus via 360° threading for excellent tightness in all conditions.

Il collo è stato disegnato secondo principi ergonomici per consentire una perfetta impugnatura e rendere l'operazione di versatura pratica e veloce in tutte le condizioni di utilizzo. La sua particolare filettatura (a doppio giro) garantisce una tenuta totale, rendendolo nel contempo universale, può essere infatti montato non solo su tutte le riserve versus ma anche su quelle delle altre marche più diffuse.

The ergonomic design of the neck makes for a perfect grip and practical, fast operation in all conditions. The special threading (double turn) guarantees perfect tightness and an universal fitting not only to the versus juice containers but to other leading brands, too.

La riserva, disponibile in varie capacità, con la sua comoda scala graduata consente l'immediata visione della quantità di prodotto presente all'interno.

The juice containers, available in various sizes, have a useful graduated scale and you can immediately see how much liquid they contain.

La base zigrinata della riserva permette il perfetto ancoraggio del suo coperchio quando questo viene rimosso per inserire il collo.

The knurled base of the juice containers allows a perfect fitting of its cover once removed to assemble the neck.



Versus completo da 2 lt

| Complete versus 2 lt | Cod. | Col. | cl | Box |
|----------------------|---------------|------|-----|-----|
| | 500400 | | 200 | 12 |
| | 500401 | | 200 | 12 |
| | 500403 | | 200 | 12 |
| | 500404 | | 200 | 12 |
| | 500406 | | 200 | 12 |



**Versus riserva da 2 l.
Colori assortiti**

| Spare versus 2 lt (various colours) | Cod. | Col. | cl | Box |
|-------------------------------------|---------------|------|-----|-----|
| | 500500 | | 200 | 12 |



Versus con beccuccio versatore

| Versus with pouring spout | Cod. | Col. | cl | Box |
|---------------------------|---------------|------|-----|-----|
| | 500800 | | 100 | 12 |



Speed bottle completo da 1 litro

| Speed bottle 1 litro | Cod. | Col. | cl | Box |
|----------------------|---------------|------|-----|-----|
| | 500900 | | 100 | 12 |
| | 500901 | | 100 | 12 |
| | 500903 | | 100 | 12 |
| | 500904 | | 100 | 12 |
| | 500906 | | 100 | 12 |



Beccuccio versatore

| Pouring spout | Cod. | Col. | Box |
|---------------|---------------|------|-----|
| | 500811 | | 48 |
| | 500813 | | 48 |
| | 500814 | | 48 |
| | 500816 | | 48 |



Beccuccio versatore "Versus"

| "Versus" pouring spout | Cod. | Col. | Box |
|------------------------|-----------------|------|-----|
| | 50100112 | | 4 |
| | 50100312 | | 4 |
| | 50100412 | | 4 |
| | 50100612 | | 4 |



Versus con beccuccio versatore

| Versus with pouring spout | Cod. | cl | Box |
|---------------------------|---------------|-----|-----|
| | 500890 | 100 | 12 |



Coperchio chiusura "Versus"

| "Versus" lid | Cod. | Col. | Box |
|--------------|----------------|------|-----|
| | 5011016 | | 8 |
| | 5011036 | | 8 |
| | 5011046 | | 8 |
| | 5011066 | | 8 |





Bordatore di bicchieri nero a 2 unità in plastica

2-tier black plastic glass rimmer

Cod. 502600



Bordatore di bicchieri nero a 3 unità in plastica

3-tier black plastic glass rimmer

Cod. 502700



Portaoggetti da bar in plastica

Plastic bar organizer

Cod. 502500

L x W cm H cm
24 x 14 10



Spugna sostitutiva per bordatori

Spare sponge for glass rimmer

Cod. 502800





Tappetino da bar in plastica

| Plastic bar mat | Cod. | L x W cm | Col. |
|-----------------|---------------|------------|------|
| | 502900 | 7,5 x 58,5 | ● |
| | 502903 | 8,5 x 60 | ● |

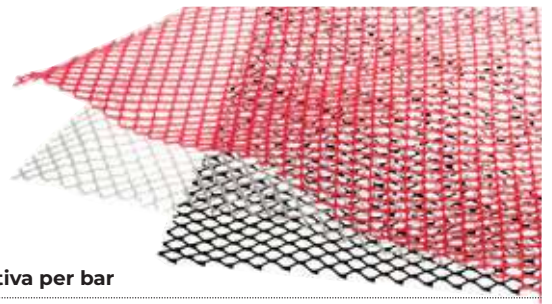

Rete protettiva per bar

| Protection mesh for bar | Cod. | L x W cm | Col. |
|-------------------------|---------------|----------|------|
| | 503400 | 61 x 610 | ● |
| | 503401 | 61 x 610 | ● |
| | 503402 | 61 x 610 | ○ |



Tappetino da servizio nero in plastica

| Black plastic bar mat | Cod. | L x W cm |
|-----------------------|---------------|-----------|
| | 503000 | 30,5 x 46 |



Tappetino scolabicchieri

| Dri-dek interlocking glass mat | Cod. | L x W cm | Col. |
|--------------------------------|---------------|----------|------|
| | 503410 | 33 x 33 | ● |
| | 503411 | 33 x 33 | ○ |



Tagliere in polietilene nero

| Black polyethylene cutting board | Cod. | L x W cm | H cm |
|----------------------------------|---------------|----------|------|
| | 503200 | 30 x 50 | 2 |

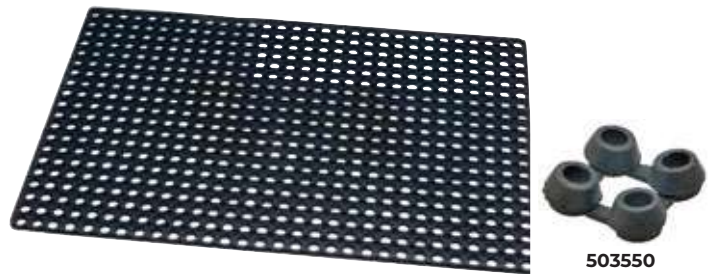

Tappeto antiscivolo

| Non slip matting | Cod. | L x W cm |
|------------------|---------------|---|
| | 503500 | 91 x 91 |
| | 503501 | 80 x 120 |
| | 503502 | 100 x 150 |
| | 503550 | Ganci fissaggio/Carpet hooks (5 pz/pcs) |

NEW



Tagliere in polietilene bianco con canalina

| White polyethylene cutting board with canal | Cod. | L x W cm | H cm |
|---|---------------|----------|------|
| | 503205 | 12 x 22 | 1 |



503700

503701

Flair bottle professionale

Professional flair bottle

| Cod. | cl |
|--------|----|
| 503700 | 75 |
| 503701 | 75 |



503703

503705

Flair bottle

Flair bottle

| Cod. | cl | Col. |
|--------|----|------|
| 503703 | 75 | ○ |
| 503705 | 75 | ○ |



Flair bottle

Flair bottle

| Cod. | cl | Col. |
|--------|----|------|
| 503710 | 75 | ○ |
| 503712 | 75 | ○ |
| 503713 | 75 | ● |
| 503716 | 75 | ● |



Portacenere in acciaio rotondo

Round steel ashtray

| Cod. | Ø cm | Box |
|--------|------|-----|
| 481113 | 13 | 12 |



Posacenere in alluminio

Aluminum ashtray

| Cod. | Ø cm | Col. |
|--------|------|------|
| 490408 | 10 | ○ |



Posacenere rotondo in plastica

Round plastic ashtray

| Cod. | Ø cm | Col. | Box |
|--------|------|------|-----|
| 504100 | 10 | ● | 6 |
| 504101 | 10 | ● | 6 |



Posacenere rotondo in plastica

Round plastic ashtray

| Cod. | Ø cm | Col. | Box |
|--------|------|------|-----|
| 504200 | 14 | ● | 6 |
| 504201 | 14 | ● | 6 |





Dispenser in polietilene

| Polyethylene dispenser | Cod. | ml | ozs | Col. | Box |
|------------------------|----------------|-----|-----|------|-----|
| | 5045016 | 236 | 8 | ● | 6 |
| | 5045026 | 236 | 8 | ○ | 6 |
| | 5045036 | 236 | 8 | ● | 6 |
| | 5046016 | 354 | 12 | ● | 6 |
| | 5046026 | 354 | 12 | ○ | 6 |
| | 5046036 | 354 | 12 | ● | 6 |
| | 5047016 | 708 | 24 | ● | 6 |
| | 5047026 | 708 | 24 | ○ | 6 |
| | 5047036 | 708 | 24 | ● | 6 |



Bicchieri in plastica trasparente

| Clear plastic glass | Cod. | ml | Box |
|---------------------|---------------|-----|-----|
| | 505700 | 360 | 50 |
| | 505701 | 400 | 50 |
| | 505702 | 290 | 80 |
| | 505705 | 40 | 60 |
| | 505750 | 400 | 50 |



Bicchieri in plastica

| Plastic glass | Cod. | ml | ozs | Box |
|---------------|---------------|-----|-----|-----|
| | 504902 | 236 | 8 | 72 |



Bicchieri in polipropilene ghiaccio

| Iced polypropylene glass | Cod. | ml | Box |
|--------------------------|---------------|-----|-----|
| | 505800 | 360 | 50 |
| | 505801 | 400 | 50 |



Bicchieri in plastica zigrinato trasparente

| Clear knurled plastic glass | Cod. | ml | ozs | Box |
|-----------------------------|---------------|-----|-----|-----|
| | 505300 | 148 | 5 | 72 |
| | 505301 | 237 | 8 | 72 |
| | 505302 | 296 | 10 | 72 |
| | 505303 | 355 | 12 | 72 |



Caraffa in plastica trasparente

| Clear plastic carafe | Cod. | Lt | Box |
|----------------------|---------------|------|-----|
| | 506200 | 0,95 | 6 |
| | 506201 | 1,4 | 6 |
| | 506202 | 1,8 | 6 |





Portazucchero trasparente in plastica

Clear plastic sugar bowl Cod. **5074022** Box 6



Cannuccia diritta in acciaio inox

Straight stainless steel straw Cod. **517021** L cm 13



CON SCOVOLINO WITH STRAW CLEANER



Cannuccia diritta in acciaio inox

Straight stainless steel straw Cod. **517121** L cm 21,5



CON SCOVOLINO WITH STRAW CLEANER

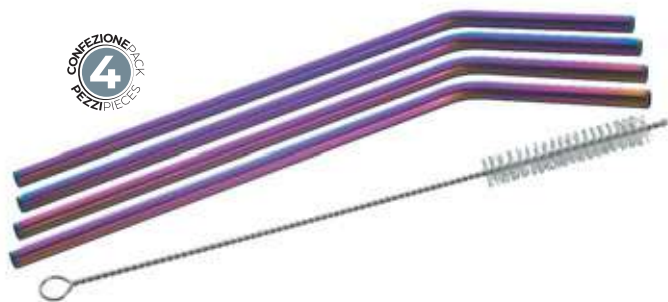

Cannuccia piegata in acciaio inox colorato

Bended coloured stainless steel straw Cod. **517420** L cm 21,5



CON SCOVOLINO WITH STRAW CLEANER



Portazucchero in plastica

| | | | |
|--------------------|----------------|------|-----|
| Plastic sugar bowl | Cod. | Col. | Box |
| | 5075002 | ● | 6 |
| | 5075012 | ● | 6 |
| | 5075022 | ○ | 6 |
| | 5075032 | ● | 6 |
| | 5075042 | ● | 6 |



Portatovaglioli in plastica

| | | | |
|--------------------------|----------------|------|-----|
| Plastic serviette holder | Cod. | Col. | Box |
| | 5079002 | ● | 6 |
| | 5079022 | ○ | 6 |



Poggiavassoio in legno color nero con gommini antiscivolo

| | | | |
|---|---------------|----------|------|
| Black wood tray rest with non slip rubber pad | Cod. | L x W cm | H cm |
| | 506900 | 43 x 43 | 83 |





Cestino in polipropilene ovale

| Oval polypropylene basket | Cod. | L x W cm | Col. | Box |
|---------------------------|----------------|----------|------|-----|
| | 5070016 | 24 x 15 | ● | 6 |
| | 5070036 | 24 x 15 | ● | 6 |
| | 5070046 | 24 x 15 | ● | 6 |
| | 5070056 | 24 x 15 | ● | 6 |
| | 5070066 | 24 x 15 | ● | 6 |

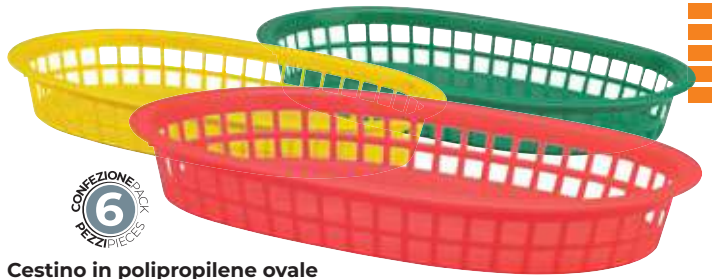

Cestino in polipropilene ovale

| Oval polypropylene basket | Cod. | L x W cm | Col. | Box |
|---------------------------|----------------|----------|------|-----|
| | 5071016 | 28 x 18 | ● | 6 |
| | 5071036 | 28 x 18 | ● | 6 |
| | 5071046 | 28 x 18 | ● | 6 |



Cestino in polipropilene color vimini naturale rotondo

| Round polypropylene natural wicker basket | Cod. | Ø cm | H cm |
|---|---------------|------|------|
| | 508518 | 18 | 5 |
| | 508521 | 21 | 6 |



NON ADATTO ALLA LAVASTOVIGLIE
NOT DISHWASHER SAFE



Cestino in polipropilene color vimini naturale rettangolare

| Rectangular polyprop. natural wicker basket | Cod. | L x W cm | H cm |
|---|---------------|----------|------|
| | 508623 | 23 x 15 | 6 |



NON ADATTO ALLA LAVASTOVIGLIE
NOT DISHWASHER SAFE



Cestino in polipropilene color vimini naturale ovale

| Oval polypropylene natural wicker basket | Cod. | L x W cm | H cm |
|--|---------------|----------|------|
| | 508718 | 18 x 13 | 5 |
| | 508723 | 23 x 16 | 6 |
| | 508725 | 25 x 17 | 8 |



NON ADATTO ALLA LAVASTOVIGLIE
NOT DISHWASHER SAFE

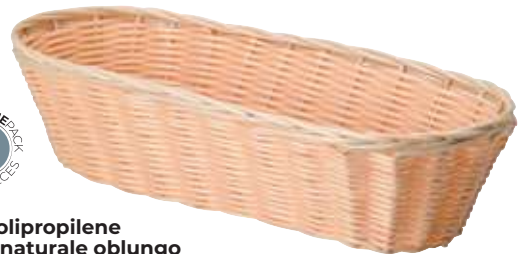

Cestino in polipropilene color vimini naturale oblungo

| Oblong polypropylene natural wicker basket | Cod. | L x W cm | H cm |
|--|---------------|----------|------|
| | 508823 | 23 x 9 | 5 |
| | 508828 | 28 x 15 | 8 |
| | 508833 | 33 x 13 | 8 |



NON ADATTO ALLA LAVASTOVIGLIE
NOT DISHWASHER SAFE



Cestino in polipropilene intrecciato marrone rotondo

| Round brown woven polypropylene basket | Cod. | Ø cm | H cm |
|--|---------------|------|------|
| | 509529 | 29 | 8 |



NON ADATTO ALLA LAVASTOVIGLIE
NOT DISHWASHER SAFE



Cestino in polipropilene intrecciato marrone ovale

| Oval brown woven polypropylene basket | Cod. | L x W cm | H cm |
|---------------------------------------|---------------|-----------|------|
| | 509627 | 27,5 x 20 | 7 |



NON ADATTO ALLA LAVASTOVIGLIE
NOT DISHWASHER SAFE



BB340E

BB320E

Frullatore da bar 1 CV

| | | |
|-------------------------|--------------------|-----|
| 1 HP commercial blender | Cod. | cl |
| | 5610-BB320E | 140 |
| | 5610-BB340E | 140 |



- **Potente motore da 1 CV a 2 velocità con funzione Impulso**
1 HP commercial motor, 2-speed with PULSE function
- **Contenitore da 1,4 litri in copoliestere privo di BPA, lama in acciaio inox**
1.4 liter BPA-free copolyester container with industrial stainless steel blade
- **La base removibile gommata del bicchiere riduce il rumore e facilita la pulizia**
Removable rubberized jar pad dampens sound and makes cleanup easy
- **Tre Margarita da 475 ml in 12 secondi o anche meno**
Three 475 ml. (16 oz.) Margaritas in 12 seconds or less
- **Ideale per preparare da 25 a 50 drinks al giorno**
Recommended for 25-50 drinks per day
- **230 VCA, 750W**



BB320E TASTIERA ELETTRONICA
ELECTRONIC KEYPAD



BB340E TASTIERA ELETTRONICA CON TIMER
DA 99 SECONDI
ELECTRONIC KEYPAD WITH 99-SECOND COUNTDOWN TIMER

Xtreme - Frullatore ad alta potenza 3,5 CV

| | | |
|-------------------------|-------------------------|-----|
| Xtreme - 3.5 HP blender | Cod. | cl |
| | 5615-MX1000XTXEE | 200 |
| | 5615-MX1100XTXEE | 200 |
| | 5615-MX1200XTXEE | 200 |
| | 5615-MX1300XTXEE | 200 |
| | 5615-MX1500XTXEE | 200 |



- **Motore da 3,5 CV di picco per carichi di lavoro intensi**
Heavy-duty 3½ peak HP motor
- **Velocità pura del motore 32.000 giri/min, 1500 watt**
32,000 RPM bare motor speed, 1500 watts
- **Base del bicchiere monopezzo removibile lavabile in lavastoviglie**
One-piece dishwasher-safe removable jar pad
- **Contenitore da 2 litri in copoliestere privo di BPA**
2 L BPA-free copolyester container
- **Disponibili contenitori in copoliestere privo di BPA da 1,4 litri e in acciaio da 1,4 e 2 litri**
1.4 L BPA-free copolyester container and 1.4 and 2 L stainless steel containers available
- **Disponibilità di involucro antirumore**
(incluso nel modello MX1500)
Optional sound enclosure (included for MX1500)
- **230 VCA, 50 Hz, 6,5 amp**
- **Disponibili anche nella versione 60 Hz**
Also available in 60 Hz



MX1300XTXEE
INVOLUCRO ANTIRUMORE
NON INCLUSO
SOUND ENCLOSURE
NOT INCLUDED
MX1500XTXEE



MX1000XTXEE
INTERRUTTORI A PALETTA
CON HI (ALTO), LO (BASSO),
E PULSE (IMPULSO)
PADDLE SWITCHES WITH
HIGH, LOW AND PULSE



MX1100XTXEE
TASTIERA ELETTRONICA
CON HI (ALTO), LO (BASSO),
PULSE (IMPULSO)
E TIMER DA 30 SECONDI
ELECTRONIC KEYPAD WITH
HIGH, LOW, PULSE
FUNCTIONS AND 30-SECOND
TIMER



MX1200XTXEE
MANOPOLA VARIATORE
DI VELOCITÀ E PULSE
(IMPULSO) CON
INTERRUTTORE A PALETTA
VARIABLE SPEED DIAL
CONTROL AND PULSE
PADDLE SWITCH



MX1300XTXEE
MX1500XTXEE
TASTIERA ELETTRONICA
PROGRAMMABILE, LCD
DISPLAY E COMANDO
PULSE PROGRAMMABLE
ELECTRONIC KEYPAD, LCD
DISPLAY AND PULSE



MX1000XTXEE

MX1100XTXEE

MX1200XTXEE





TBB175E

Frullatore da bar Torq 2.0 - 1,4 L

| Blender Torq 2.0 - 1.4 L | Cod. | cl |
|--------------------------|---------------------|-----|
| | 5610-TBB145E | 140 |
| | 5610-TBB160E | 140 |
| | 5610-TBB175E | 140 |



- **Motore da 2 CV, a 2 velocità ad alte prestazioni**
High-performance 2HP motor, 2 speeds
- **Tre Margarita da 475 ml in 8 secondi o anche meno**
Three 475 ml. (16 oz.) Margaritas in 8 seconds or less
- **Contenitore da 1,4 litri in copoliestere privo di BPA, impilabile**
1.4 L BPA-free unbreakable copolyester container
- **Coperchio removibile in gomma alimentare, con foro per aggiungere ingredienti**
Vinyl lid with removable center cap to feed ingredients while blending
- **Resistente giunto di trasmissione in acciaio inossidabile sostituibile**
Heavy-duty stainless steel replaceable drive and jar couplings
- **230 VCA, 60 Hz, 13 amp**



TBB145E
COMMUTATORI
HI/LO/OFF
(ALTO/BASSO/STOP)
E PULSE (IMPULSO)
HI/LO/OFF AND PULSE
TOGGLE SWITCHES



TBB160E
TASTIERA
ELETTRONICA
CON TIMER DA 60
SECONDI
ELECTRONIC KEYPAD
WITH 60-SECOND
COUNTDOWN TIMER



TBB175E
MANOPOLA
VARIATORE
DI VELOCITÀ
1000 - 17000 GIRI/MIN
VARIABLE SPEED
CONTROL DIAL
1000 - 17000 RPM

Frullatore da 4 Litri

| 4 liter food blender | Cod. | cl |
|----------------------|--------------------|-----|
| | 5610-CB15VE | 400 |



- **Motore da 3,75 CV per carichi di lavoro intensi**
Heavy-duty 3¾ HP motor
- **I comandi meccanici aumentano la versatilità con 3 velocità e PULSE (impulso)**
Mechanical controls add versatility with 3 speeds and PULSE
- **Contenitore in acciaio inossidabile con due maniglie e coperchio gommato**
Stainless steel container with two handles and rubberized lid
- **Nuova base del bicchiere monopezzo lavabile in lavastoviglie per una facile pulizia**
New dishwasher-safe one-piece jar pad for easy cleaning
- **Comandi velocità variabile**
Variable speed controls
- **230 VCA, 50 Hz**
- **Approvato CE**
CE approved



NEW

Mixer a immersione compatto

| | | |
|------------------------------|--------------------|-------|
| Light-duty immersion blender | Cod. | L cm* |
| | 5600-WSB35E | 17,8 |



* Lunghezza albero / Shaft length

- **Motore ad alta efficienza a 2 velocità (7.500 e 18.000 giri/min)**
2-speed (7,500 and 18,000 RPM), high-efficiency motor
- **Albero da 17,8 cm fisso**
17.8 cm fixed shaft
- **Leggero e compatto**
Lightweight and compact
- **Lama polivalente in acciaio inossidabile**
All-purpose stainless steel blade
- **11,3 litri di capacità**
11.3-liter capacity
- **120 volt, 60 Hz, 100 W, 0,8 amp**
- **Approvato CE, RoHS**
CE, RoHS approved

Ø7 CM



Blender immersione standard

| | | |
|----------------------------|--------------------|-------|
| Standard immersion blender | Cod. | L cm* |
| | 5600-WSB40E | 25,5 |



* Lunghezza albero / Shaft length

- **Motore da 0,5 CV a 2 velocità (7.500 e 18.000 giri/min) per carichi di lavoro intensi**
½ HP, 2-speed (7,500 and 18,000 RPM), heavy-duty motor
- **Albero da 25,5 cm fisso**
25.5 cm fixed shaft
- **Comoda impugnatura gommata**
Rubberized comfort grip
- **Lama polivalente in acciaio inossidabile**
All-purpose stainless steel blade
- **23 litri di capacità**
23-liter capacity
- **230 volt, 50 Hz, 1,5 amp**
- **Approvato CE, RoHS**
CE, RoHS approved

Ø8,4 CM



Attacco frusta per blender alta prestazione

| | | |
|--------------------------------------|-------------------|------|
| Heavy-duty whisk whipping attachment | Cod. | L cm |
| | 5600-WSB2W | 25,5 |



- **Palette per montare da 25,5 cm in acciaio inossidabile**
25.5-cm stainless steel whipping paddles
- **Si adatta all'intera linea di mixer a immersione Big Stix per carichi di lavoro intensi**
Fits entire Big Stix Heavy-Duty Immersion Blender line
- **Giunto sostituibile dall'utilizzatore**
User-replaceable coupling
- **Ingranaggi pressofusi per prestazioni ottimali**
Die-cast gears for optimal performance
- **Approvato CE, RoHS**
CE, RoHS approved



Mixer bevande a testina singola

Drink mixer,
single spindle

Cod.
5620-WDM120TXE



- **Il motore ad alte prestazioni è sostituibile dall'utente per il funzionamento continuo e include una protezione termica per prolungarne la vita**
Independent, high-performance motor are user-replaceable for continued operation and includes thermal protection to prolong motor life
- **I comandi elettronici a 3 velocità (15.000, 18.000 e 21.000 giri/min) e a impulsi mantengono la velocità sotto carico per prestazioni ottimali**
Electronic 3-speed and pulse controls maintain speed under load for optimal performance - 15,000, 18,000 and 21,000 RPM
- **Gli attuatori completamente chiusi impediscono l'ingresso della miscela nell'alloggiamento**
Fully enclosed actuators prevent mix from entering the housing
- **2 agitatori sulla testina: un agitatore solido per la miscelazione di gelati duri e l'aerazione per una maggiore resa e un agitatore a farfalla per gelati e miscele più morbide**
2 agitators on the spindle: one solid agitator for mixing hard ice creams and aerating for increased yield, and one butterfly agitator for softer ice creams and mix-ins
- **Posizionamento del bicchiere senza doverlo inclinare**
Increased cup clearance: slide cups into position without tilt
- **Funzionamento START/STOP completamente automatico, attivato dalla tazza, con una sola mano**
Fully automatic, cup-activated, one-handed START/STOP operation
- **Resistente, verniciato a polvere, alloggiamento in acciaio pressofuso**
Heavy-duty, powder-coated, die-cast steel housing
- **Bicchiere in acciaio in dotazione da 800 ml**
Stainless steel malt beverage cup (800 ml) included
- **220 VCA, 60 Hz**
- **Approvato CE, RoHS**
CE, RoHS approved



Mixer bevande a testina doppia o tripla

Drink mixer, double
or triple spindle

| | |
|--------------|-----------------|
| Cod. | Testina/Spindle |
| 5620-WDM240E | doppia/double |
| 5620-WDM360E | tripla/triple |



- **2 motori (WDM240) o 3 motori (WDM360) indipendenti per carichi di lavoro intensi per complessivi 1,3 CV a 3 velocità (16.000, 20.000 e 24.000 giri/min) e impulso**
Two (WDM240) or three (WDM360) independent 1 peak HP motor, three-speed rocker switch (16,000, 20,000 and 24,000 RPM) and PULSE switch
- **Accensione e spegnimento automatico, a velocità impostata, semplicemente inserendo o togliendo il bicchiere dall'alloggiamento**
Fully automatic START/STOP operation.
Motor will run at selected speed once cup is in position
- **Posizionamento del bicchiere senza doverlo inclinare**
Slide cups into position without tilt
- **Struttura in metallo pressofuso adatto ad un uso intenso**
Heavy-duty die-cast housing – easy to clean
- **Agitatore solido di nuova concezione per dare risultati migliori anche con i gelati più duri**
Brand new ultra-aggressive agitator powers through the hardest ice creams
- **Agitatore a farfalla incluso nella confezione, per gelati morbidi e per diverse tipologie di bicchieri**
Also includes butterfly agitator for softer ice creams and use with many types of cups
- **Bicchieri in acciaio in dotazione da 800 ml**
Stainless steel malt beverage cups (800 ml) included
- **Motori con protezione termica.**
Motors incorporate thermal protection
- **Cuscinetto a sfera autolubrificante per un uso intenso e duraturo**
Sealed ball bearings – ball bearings are lubed for life with no need to replace, providing long service life
- **220 VCA, 60 Hz, 110 W, 1,15 amp**
- **Approvato CE, RoHS**
CE, RoHS approved



WDM240E

WDM360E



SISTEMA DI TENUTA LIQUILOCK®
LIQUILOCK® SEAL SYSTEM

**Cutter tagliaverdura 3,8 L
2 CV con espulsore**

3.8 L cutter mixer
and continuous-feed
food processor

Cod. cl
5605-WFP16SCDE 380



- **Sistema di tenuta LiquiLock**
LiquiLock Seal System
- **Alloggiamento pressofuso per carichi di lavoro intensi**
Heavy-duty, die-cast housing
- **Motore commerciale da 2 CV (picco potenza)**
2 HP (peak input) commercial motor
- **Scivolo ad alimentazione continua per lavorazione di grandi volumi**
Continuous-feed chute for large-volume processing

- **La ciotola del mixer con taglierina sigillata da 3,8 L lavora facilmente zuppe, salse, condimenti e altro**
3.8 L sealed cutter mixer bowl processes soups, sauces, dressings and more with ease
- **Oltre 20 opzioni di lavorazione in una sola macchina**
Over 20 processing options in one machine
- **Elaborazione unica della ciotola; sminuzzare, grattugiare e affettare direttamente nella ciotola con il gambo del disco incluso**
Unique batch bowl processing; shred, grate and slice directly in the batch bowl with the included disc stem
- **220-240 VCA, 50-60 Hz, 700 W**
- **Approvato CE, RoHS**
CE, RoHS approved

ACCESSORI INCLUSI CON I MODELLI WFP16
ACCESSORIES INCLUDED WITH WFP16 FOOD PROCESSORS



Cutter tagliaverdura da cucina 3,8 L, 0,65 CV

3.8 L cutter mixer
food processor

Cod. cl
5605-WFP16SE 380



- **Sistema di tenuta LiquiLock**
LiquiLock Seal System
- **Alloggiamento pressofuso per carichi di lavoro intensi**
Heavy-duty, die-cast housing
- **Ciotola del miscelatore con taglierina da 3,8 L, praticamente infrangibile e ben visibile con sistema di tenuta LiquiLock® per la lavorazione di liquidi**
3.8 L, virtually unbreakable, clear-view cutter mixer bowl with LiquiLock® Seal System for processing liquids
- **Motore commerciale da 650 W**
650 W commercial motor
- **Pulsanti di controllo grandi e di facile lettura**
Large, easy-to-read control buttons
- **Oltre 20 opzioni di lavorazione in una sola macchina**
Over 20 processing options in one machine
- **Elaborazione unica della ciotola; sminuzzare, grattugiare e affettare direttamente nella ciotola con il gambo del disco incluso**
Unique batch bowl processing; shred, grate and slice directly in the batch bowl with the included disc stem
- **220-240 VCA, 50-60 Hz, 700 W**
- **Approvato CE, RoHS**
CE, RoHS approved



PIÙ PRODUZIONE IN MENO TEMPO. NESSUN DISORDINE

Il sistema di tenuta LiquiLock® brevettato da Waring consente una maggiore produzione in meno tempo.

Ottieni il massimo dalla capacità della tua ciotola senza alcuna perdita di liquido.

La lama a S si blocca in sede, sigillando il fondo della ciotola, rendendo più sicuro, più pulito e più facile versare le miscele senza che la lama cada nella ciotola degli alimenti lavorati.

La guarnizione rimovibile nel coperchio con chiusura a scatto impedisce al liquido di fuoriuscire dalla parte superiore della ciotola, consentendo di riempirla fino all'orlo.

MORE PRODUCTS. LESS TIME. NO MESS

Waring's patented LiquiLock® Seal System allows for more production in less time. Get the most out of your bowl capacity with bottom- to top-of-the-bowl liquid processing with no leaking.

The patented S-blade locks into place, sealing the bottom of the bowl, making it safer, cleaner, and easier to pour mixtures without the blade falling out into the processed food bowl.

The removable seal in the snap-lock lid prevents any liquid from escaping the top of the bowl.

Fill it to the rim without overflowing.





**Cutter tagliaverdura 3,3 L
1 CV con espulsore**

3.3 L cutter mixer and continuous-feed food processor
Cod. **5605-WFP14SCE** cl 330



- **Sistema di tenuta LiquiLock**
LiquiLock Seal System
- **Motore da 1 CV ad alte prestazioni**
High-performance 1 HP motor
- **Palette di controllo agevoli, per accensione (ON) e impulso/spengimento (PULSE/OFF)**
Easy ON and PULSE/OFF control paddles
- **Tubo di immissione e spingicibo di grandi dimensioni**
Extra-large feed tube and food pusher
- **Scivolo per immissione continua in policarbonato con maniglie, per preparare grandi volumi**
Continuous-feed rugged black polycarbonate chute for large volume processing
- **Resistente coperchio trasparente**
Durable see-through cover
- **230 VCA, 50 Hz, 2,6 amp**
- **Approvato CE, RoHS**
CE, RoHS approved

Cutter tagliaverdura da cucina 3,3 L, 1 CV

3.3 L cutter mixer food processor
Cod. **5605-WFP14SE** cl 330



- **Sistema di tenuta LiquiLock**
LiquiLock Seal System
- **Motore da 1 CV ad alte prestazioni**
High-performance 1 HP motor
- **Palette di controllo agevoli, per accensione (ON) e impulso/spengimento (PULSE/OFF)**
Easy ON and PULSE/OFF control paddles
- **Tubo di immissione e spingicibo di grandi dimensioni**
Extra-large feed tube and food pusher
- **Bicchieri dosatore a tenuta**
Sealed batch bowl
- **230 VCA, 50 Hz, 2,6 amp**
- **Approvato CE, RoHS**
CE, RoHS approved



ACCESSORI INCLUSI CON I MODELLI WFP14
ACCESSORIES INCLUDED WITH WFP14 FOOD PROCESSORS



Cutter tagliaverdura da cucina 1,75 L, 0,75 CV

1.75 L commercial food processor
Cod. **5605-WFP7E** cl 175



- **Motore da 0,75 CV ad alte prestazioni per carichi di lavoro intensi**
Heavy-duty ¾ HP high performance motor
- **Bicchiere da lavoro infrangibile e trasparente**
Clear-view unbreakable workbowl
- **Facilità di controllo ON (accensione), OFF (spegnimento) e PULSE (impulso)**
Easy ON/OFF/PULSE control
- **Lama a S seghettata in acciaio inossidabile per trinciare, macinare, miscelare e passare, disco affettatore da 2 mm, disco grattugia sottile e stelo del disco staccabile**
Stainless steel serrated S-blade to chop, grind, mix and purée, disc, fine grating disc, and detachable disc stem
- **Spingicibo di dimensioni piccole e grandi con manico di interblocco di sicurezza**
Small and large pushers with safety interlock sleeve
- **230 VCA, 50 Hz, 410 W, 1,8 amp**
- **Approvato CE, RoHS**
CE, RoHS approved



Macina spezie

Commercial spice grinder
Cod. **5660-WSG30E**



- **Macina finemente bastoncini di cannella, noce moscata, granelli di pepe nero e molto altro in pochi secondi**
Finely grinds cinnamon sticks, nutmeg, peppercorns and much more in seconds
- **Motore di qualità commerciale a elevate prestazioni 19.000 giri/min.**
High-performance commercial-grade motor - 19,000 Rpm
- **Alloggiamento per carichi di lavoro intensi in acciaio inossidabile opacizzato con coperchio a interblocco di sicurezza**
Heavy-duty brushed stainless steel housing with safety interlock lid
- **Azionamento PULSE (Impulso) per gestire facilmente le dimensioni della macinatura**
PULSE actuation to easily manage consistency of grind
- **In dotazione 3 bicchieri di macinatura completamente rimovibili, lavabile in lavastoviglie in acciaio inox con comodi coperchi per la conservazione**
Includes 3 fully removable and dishwasher-safe stainless steel grinding bowls with convenient storage lids
- **Lame resistenti in acciaio inossidabile**
Durable stainless steel blades
- **230 VCA, 50 Hz, 175 W, 0,76 amp**
- **Approvato CE, RoHS**
CE, RoHS approved



Planetaria

Planetary mixer

Cod.

5605-WSM7LE



- **Trasmissione ad ingranaggi, lubrificazione permanente**
Gear-driven, permanent lube transmission
- **Grande ciotola in acciaio inossidabile da 6,6 L con manico in acciaio inossidabile**
Large, 6.6 L stainless steel bowl with stainless steel handle
- **Controlli frontali e LED luce di alimentazione**
Front-mounted controls and LED power light
- **11 velocità di miscelazione con manopola di controllo della velocità variabile**
11 mixing speeds with variable speed control dial
- **Paraspruzzi rimovibile e trasparente con scivolo di alimentazione**
Removable clear-view splash guard with feed chute
- **Testa inclinabile per una facile rimozione degli accessori e pulizia**
Tilt-back head for easy removal of attachments and cleaning
- **Leva di sollevamento/rilascio per impieghi gravosi**
Heavy-duty head-lift/release lever
- **Protezione da sovraccarico termico**
Thermal overload protection
- **Include ciotola in acciaio inossidabile, frusta da chef, gancio per impastare e pala per mescolare in alluminio**
Includes stainless steel bowl, chef's whisk, dough hook and aluminum mixing paddle
- **Accessori lavabili in lavastoviglie**
Dishwasher-safe accessories
- **Piedini in gomma antiscivolo**
Nonslip rubber feet
- **220-240 V, 50-60 Hz, 350 W**

ACCESSORI INCLUSI CON IL MODELLO WSM7LE
ACCESSORIES INCLUDED WITH WSM7LE PLANETARY MIXER



PALETTA PER MISCELARE
MIXING PADDLE



FRUSTA CHEF'S WHISK



GANCIOPER IMPASTARE
DOUGH HOOK



CIOTOLA IN ACCIAIO INOX
STAINLESS STEEL BOWL



Affilatore per coltelli

Commercial knife sharpener

Cod.

5665-WKS800E



- **Due mole (grani fini/grossi), una coramella rotante**
Two grinding wheels (fine/coarse) one stropping wheel
- **Mola ad angoli di 18-22°: gli angoli consigliati dai produttori di coltelli**
Grinds at 18-22° angles - optimum angles recommended by knife manufacturers
- **La coramella rotante funziona anche in senso inverso, consentendo un'eliminazione più efficace delle sbavature e la levigatura della lama**
Stropping wheel also operates in reverse direction, allowing for a more efficient removal of burrs and polishing of the blade
- **Un cassetto magnetizzato sotto la mola raccoglie le schegge metalliche rasate**
Magnetized drawer under grinding wheel captures metal shavings
- **230 VCA, 50/60 Hz, 25 W, 0,1 amp**
- **Approvato CE, RoHS**
CE, RoHS approved



Centrifuga in acciaio inox con espulsione della polpa

Heavy-duty pulp eject juice extractor : Cod. **5630-WJX90E**



- **Consigliato per carichi di lavoro intensi in bar, caffetterie, ristoranti, hotel e strutture sanitarie**
Use in high-volume smoothie shops, cafés, bars, restaurants, hotels and healthcare establishments
- **Cestello filtro in acciaio inox e disco tritratore progettati per una resa ottimale e una riduzione degli sprechi**
Stainless steel filter basket and shredder disc designed for a fantastic yield to minimize waste
- **Compatto e leggero**
Compact and lightweight
- **Facile da pulire (tutte le parti sono lavabili in lavastoviglie)**
Easy to clean with all dishwasher-safe parts
- **Ampio scivolo di alimentazione da 8 cm**
Large, 8 cm feed chute for less prep work
- **Grande contenitore per polpa da 11 L**
Large, 11 L pulp container
- **Interblocco di sicurezza**
Includes safety interlock features
- **Beccuccio rotante antigoccia**
Rotating, no-drip spout reduces mess
- **220-240 V, 50-60 Hz, 1000 W**
- **Approvato CE**
CE approved



Centrifuga in acciaio inox

Heavy-duty juice extractor : Cod. **5630-6001X**



- **Trasforma rapidamente frutta e verdura in un ricco succo privo di polpa**
Rapidly converts fruits and vegetables into rich, pulp-free juice
- **La lama ad azione oscillante in acciaio inossidabile velocizza il flusso del succo con una più rapida distribuzione della polpa**
Floating action stainless steel blade speeds up juice flow with faster distribution of pulp
- **Cestello, bicchiere e coperchio di spremitura in acciaio inossidabile**
Stainless steel extraction basket, bowl, and cover
- **Alloggiamento del motore in policarbonato**
Polycarbonate motor housing
- **230 VCA, 50 Hz, 1,4 amp**
- **Approvato CE, RoHS**
CE, RoHS approved



Gelatiera a compressore

Electric ice cream maker : Cod. **5680-WCIC20E** cl 200



- **Il compressore integrato non richiede precongelo**
Built-in compressor means NO pre-freezing required
- **Prepara fino a 2 L di gelato, frozen yogurt o gelato in soli 30 minuti**
Make up to 2 L of ice cream, frozen yogurt or gelato in as little as 30 minutes
- **Esterno in acciaio inossidabile e comandi touch facili da pulire**
Easy-to-clean stainless steel exterior and touch controls
- **La funzione Keep Cool mantiene il gelato alla temperatura ottimale al termine del processo**
Keep Cool feature holds ice cream at the optimal temperature when process is finished
- **220-240 V, 50 Hz, 180 W**
- **Approvato CE, RoHS**
CE, RoHS approved



FACILE AGGIUNTA DEGLI INGREDIENTI SENZA INTERRUPERE IL PROCESSO
MIX-INS COMBINE EASILY WITHOUT INTERRUPTING THE PROCESS



CIOTOLA RIMOVIBILE PER UNA FACILE PULIZIA
REMOVABLE BATCH BOWL FOR EASY CLEANING



WSW16E



WSW25E

Macchina per cottura sottovuoto

| | | |
|--------------------|-------------|----|
| Thermal circulator | Cod. | Lt |
| | 5670-WSV16E | 16 |
| | 5670-WSV25E | 25 |



- **Costruzione interamente in acciaio inossidabile**
All-stainless steel construction
- **5 stazioni di memoria programmabili e timer da 99 ore**
5 programmable memory stations and 99-hour timer
- **Precisione della temperatura di +/- 0,5° C**
Temperature accuracy of +/- 0.5° C
- **Sistema di tubi integrato per rimuovere facilmente e in sicurezza l'acqua dal serbatoio**
Integrated hose system to easily and safely remove water from reservoir
- **Il controllo touch capacitivo consente di impostare o regolare rapidamente la temperatura di cottura**
Capacitive touch control enables you to quickly set or adjust the cooking temperature
- **Intervallo di temperatura da 35°C a 90°C**
Temperature range from 35°C to 90°C (95° F - 194° F)
- **Perfetto per tutti i ristoranti e ideale per il catering**
Perfect for all restaurants and off-premises cooking.
- **220-240 V, 50-60 Hz, 2000 W**
- **Approvato CE, RoHS**
CE, RoHS approved



CONDITE IL CIBO COME DESIDERATE E METTETELO SOTTOVUOTO. I SUCCHI E LE SOSTANZE NUTRITIVE NATURALI VENGONO MANTENUTI DURANTE LA COTTURA

SEASON FOOD WITH YOUR FAVORITE HERBS AND SPICES, THEN VACUUM SEAL. NATURAL JUICES AND NUTRIENTS ARE RETAINED WHILE COOKING



POTETE PREPARARE E CUOCERE PIÙ PORZIONI IN ANTICIPO. IL CONTROLLO PRECISO DELLA TEMPERATURA E LA CIRCOLAZIONE CONTINUA DELL'ACQUA, GARANTISCONO UNA COTTURA PERFETTA

PREPARE AND COOK MULTIPLE PORTIONS AHEAD OF TIME. WITH PRECISE TEMPERATURE CONTROL AND CONTINUOUS WATER CIRCULATION, FOOD CANNOT BE UNDER- OR OVERCOOKED



Disidratatore per alimenti

| | |
|-----------------|-------------|
| Food dehydrator | Cod. |
| | 5655-WDH10E |



- **Creato per chef e mixologist che desiderano aggiungere sapori e consistenze particolari a cibi e bevande**
Built for chefs and mixologists looking to add unique flavor and texture to food and beverages
- **Display a LED digitale con comandi touch capacitivi**
Digital LED display with capacitive touch controls
- **5 stazioni di memoria per l'impostazione e la memorizzazione di programmi personalizzati**
5 memory stations for setting and storing unique programs
- **Intervallo di temperatura regolabile: 0° C - 80° C**
Adjustable temperature range: 0° C - 80° C (32° F - 176° F)
- **Visualizza la temperatura in °C o °F**
View temperature in °C or °F
- **Imposta il timer fino a 99 ore, spegnimento automatico quando il tempo finisce**
Set timer up to 99 hours, automatic shutoff when times lapses
- **10 vassoi di spazio disidratante**
10 trays of dehydrating space
- **Griglia in acciaio inox 38 x 34 cm**
38 x 34 cm stainless steel mesh racks
- **Superficie totale disidratante di 1,3 mq**
Total dehydrating surface area of 1,3 square meters
- **Porta in vetro trasparente per il monitoraggio del processo di disidratazione**
Clear-view glass door for monitoring dehydrating process
- **Sistema di flusso d'aria montato posteriormente**
Rear-mounted airflow system
- **220-240 V, 50-60 Hz, 800 W**
- **Approvato CE, RoHS**
CE, RoHS approved

Grill per panini

Compact Italian-Style panini grill

Cod.

5645-WPG150E

singolo/single

5645-WPG300E

doppio/double



- **Piastre in ghisa rigate per una distribuzione uniforme del calore e un rapido tempo di cottura**
Ribbed cast iron plates for even heat distribution and quick cooking time
- **Superfici di cottura ideali per grigliare panini, hamburger, pollo, verdure e altro**
24 x 23,5 cm (WPG 150E) - 43,25 x 23,5 cm (WPG300E)
Cooking surfaces great for grilled panini, sandwiches, hamburgers, chicken, vegetables and more
24 x 23,5 cm (WPG150E) - 43,25 x 23,5 cm (WPG300E)
- **Corpo in acciaio inossidabile opacizzato e vassoio di gocciolamento rimovibile**
Brushed stainless steel body construction and removable drip tray
- **Piastra superiore incernierata autoequilibrante per accogliere alimenti spessi fino a 7,5 cm**
Hinged, auto-balancing top plate to suit foods up to 7.5 cm thick
- **Termostato regolabile fino a 300°C**
Adjustable thermostat to 300°C (572°F)
- **Spie: Alimentazione e Pronto**
Power ON and Ready indicator lights
- **Maniglie resistenti al calore**
Heat resistant handles
- **230 VCA, 2100 Hz, 8,7 amp (WPG150E)**
230 VCA, 2900 Hz, 12,1 amp (WPG300E)
- **Approvati CE, RoHS**
CE, RoHS approved



WPG150E



WPG300E

Tostapane 4 fette

Medium duty toaster

Cod.

5640-WCT708E



- **Alloggiamento in acciaio al cromo opacizzato**
Brushed chrome steel housing
- **Quattro fessure extralarghe da 3,5 cm per panini**
Four extra-wide 3.5 cm slots, great for bagels
- **225 fette all'ora**
225 slices per hour
- **Comandi per la doratura elettronici**
Electronic browning controls
- **Quattro portafette autocentranti**
Four self-centering bread racks
- **Vassoi per le briciole rimovibili**
Removable crumb trays
- **230 V, 50 Hz, 1800 W, 7,8 amp**
- **Approvato CE, RoHS**
CE, RoHS approved



Piastra per cialde cono (singola o doppia)

Waffle cone maker
(single or double)

Cod.

5655-WWCM180E

Single

5655-WWCM200E

Double



WWCM180E



WWCM200E

- **Alloggiamento pressofuso per carichi di lavoro intensi**
Heavy-duty, die-cast housing
- **Funzione rotante per cottura e doratura uniformi**
Rotary feature for a secure and even bake
- **Le piastre antiaderenti a triplo rivestimento consentono una facile estrazione delle cialde e una rapida pulizia**
Triple-coated, nonstick surface allows for easy removal of waffle cones and minimizes cleanup
- **Tastiera di controllo elettronica facile da pulire**
Easy-to-clean electronic keypad controls
- **Spia luminosa per quando l'apparecchio è pronto e segnalazione acustica per quando la cialda è cotta**
Ready lights and audio chimes signal when unit is ready and when waffle cone is done
- **WWCM180E**
Produce fino a 60 cialde ogni ora
Bakes up to 60 waffle cones per hour
- **WWCM200E**
Produce fino a 120 cialde ogni ora
Il design verticale salva spazio e riduce il consumo energetico
Bakes up to 120 waffle cones per hour
Vertical design maximizes output, using less space and less energy
- **230 VCA, 60 Hz**



ACCESSORIO PER L'AVVOLGIMENTO DELLA CIALDA INCLUSO
INCLUDES A WAFFLE CONE ROLLING AND FORMING TOOL

Pressa per panini gelato

Ice cream sandwich press

Cod.

5680-WICSP180E



- **Alloggiamento pressofuso per carichi di lavoro intensi**
Heavy-duty die-cast housing
- **Le piastre antiaderenti a triplo rivestimento consentono una facile estrazione dei panini e una rapida pulizia**
Triple-coated nonstick plates allow for easy panini removal and quick cleanup
- **Resistenza incorporata per sigillare perfettamente i tuoi panini gelato**
Embedded heating element to perfectly seal your gelato panini
- **Pannello di controllo elettronico dalla facile pulizia**
Electronic control panel for easy cleanup
- **Segnalazioni acustiche quando l'apparecchio è pronto e quando la cialda è cotta**
Audio beep signals when unit is ready and when bun is warmed
- **Tempi di cottura da 5 a 15 secondi per un perfetto panino gelato**
Bake times from 5-15 seconds for the perfect gelato panini
- **Indicatori LED di accensione e pronto per la cottura**
Power ON and Ready-to-Bake LED indicators
- **220-240 V, 50-60 Hz, 1200 W**
- **Approvato CE, RoHS**
CE, RoHS approved

Piastra per waffle (doppia)

Belgian waffle maker (double)

Cod.
5655-WW200E



- **Alloggiamento pressofuso per carichi di lavoro intensi**
Heavy-duty die-cast housing
- **Funzione rotante per cottura e doratura uniformi**
Rotary feature for even baking and browning
- **Le piastre antiaderenti a triplo rivestimento consentono una facile estrazione delle cialde e una rapida pulizia**
Triple-coated nonstick plates allow for easy removal of waffle and quick cleanup
- **Elementi riscaldanti integrati per un controllo esatto della temperatura**
Embedded heating elements for precise temperature control
- **Segnalazioni acustiche quando l'apparecchio è pronto e quando la cialda è cotta**
Audio beep signals when unit is ready and when waffle is cooked
- **Produce fino a 50 waffle alla belga ogni ora**
Produces up to 50 Belgian waffles per hour
- **Nuovo design verticale salvaspazio con luce "Pronto" indipendente**
New space-saving vertical design with independent 'Ready' lights
- **230 VCA, 50 Hz**
- **Approvato CE, RoHS**
CE, RoHS approved



Piastra per mini waffle

Single mini Belgian waffle maker

Cod.
5655-WMB400XCE



- **Alloggiamento pressofuso per carichi di lavoro intensi**
Heavy-duty die-cast housing
- **Funzione rotante per cottura e doratura uniformi**
Rotary feature for even baking and browning
- **Le piastre antiaderenti a triplo rivestimento consentono una facile estrazione delle cialde e una rapida pulizia**
Triple-coated nonstick plates allow for easy removal of waffle and quick cleanup
- **Segnalazioni acustiche quando l'apparecchio è pronto e quando la cialda è cotta**
Audio beep signals when unit is ready and when waffle is cooked
- **Produce fino a 100 mini waffle belgi spessi 2,5 cm e con diametro di 7 cm all'ora**
Produces up to 100, 2.5 cm-thick (1 inch) and 7 cm in diameter mini Belgian waffles per hour
- **Le piastre per waffle possono essere facilmente sostituite se graffiate**
Waffle plates can be easily replaced if scratched
- **Indicatori LED di accensione e pronto per la cottura**
Power ON and Ready-to-Bake LED indicators
- **220-240 V, 50-60 Hz, 1035 W**
- **Approvato CE, RoHS**
CE, RoHS approved



Piastra per bubble waffle

Bubble waffle maker

Cod.
5655-WBW300XCE



- **Alloggiamento pressofuso per carichi di lavoro intensi**
Heavy-duty die-cast housing
- **Funzione rotante per cottura e doratura uniformi**
Rotary feature for even baking and browning
- **Le piastre antiaderenti a triplo rivestimento consentono una facile estrazione delle cialde e una rapida pulizia**
Triple-coated nonstick plates allow for easy removal of waffle and quick cleanup
- **Segnalazioni acustiche quando l'apparecchio è pronto e quando la cialda è cotta**
Audio beep signals when unit is ready and when waffle is cooked
- **Produce fino a 25 bubble waffle all'ora**
Produces up to 25 bubble waffles per hour
- **Una volta cotti i bubble waffle possono essere guarniti con gelato e/o ripieni**
Bake bubble waffles to top with ice cream and/or fillings

- **Le piastre per waffle possono essere facilmente sostituite se graffiate**
Waffle plates can be easily replaced if scratched
- **Indicatori LED di accensione e pronto per la cottura**
Power ON and Ready-to-Bake LED indicators
- **220-240 V, 50-60 Hz, 1035 W**
- **Approvato CE, RoHS**
CE, RoHS approved



WAFFLE 21 x 18 cm
30 BUBBLES

INDICE PRODOTTI

INDEX OF PRODUCTS

| | | | | | |
|------------------------------------|-----------------------------|--------------------------------------|----------------------|-------------------------------------|---------------------------|
| Affettapane | 67 | Fruste | 62 | Rotella taglia pizza | 59-111-121-149 |
| Affilacoltelli manuale | 74 | Ganci macelleria | 64 | Rullo bucasfoglia | 122 |
| Affilacoltelli elettrico | 192 | Gastronorm inox | 78-79 | Saccapoche | 116-118 |
| Agitatore | 159 | Gastronorm in plastica | 82 | Sbuccia arancia | 63-155 |
| Alare per forno | 105 | Gastronorm polipropilene | 83 | Sbucciaverdure | 63 |
| Alzate per dolci | 132-134 | Gelatiere a compressore | 193 | Scaldapasta | 47 |
| Appendipale da parete | 104 | Grattugie | 60-62-67-149 | Scavini | 63-155 |
| Apribottiglie | 160-174 | Griglia inox | 127-133 | Schiumarole | 52-54-56 |
| Arriccia burro | 63 | Griglia per decorazione | 133 | Scolapasta | 49 |
| Assi pizzeria | 93 | Grill per panini | 195 | Secchielli vino | 175 |
| Bacchette | 149 | Guanti forno | 62 | Secchiello ghiaccio | 174 |
| Bacinelle gelato | 23 | Jiggers | 159-166-167 | Sepaiatore per GN | 80 |
| Bacinelle | 49 | Lame per mandolina | 67 | Servizi per olio, aceto, sale, pepe | 148 |
| Bagnomaria | 48 | Lattiera | 158 | Sessole | 126-168-174 |
| Barra ordinazioni | 177 | Levatosolo | 63 | Setacci | 49 |
| Base per bacchette | 149 | Macchina per cottura sottovuoto | 194 | Set irtaglio e decorazione | 74-155 |
| Batticarne | 64 | Macinaspezie elettrico | 191 | Shaker | 164-165 |
| Bicchieri | 164-183 | Mandoline | 67 | Sifoni | 177 |
| Bicchieri per boston shaker | 163 | Maniglie cascanti per GN | 80 | Sottobicchieri e sottobottiglia | 160 |
| Blender | 188 | Mestolini per ciliegie | 158 | Spalmaburro | 140-142 |
| Bocchette per decorazione | 117→119 | Mestolini per salsa | 140-145 | Spargicacao | 158 |
| Bordatore di bicchieri | 180 | Mestoli | 52-54-56-140 | Spatole | 55-58-109-110-120-121-132 |
| Borsa da viaggio pizzaiolo | 97 | Misurini | 48-127 | Spazole pizzeria | 95 |
| Boston shaker | 162 | Mixer | 188→189 | Spazolone pizzeria smontabile | 96 |
| B-Pour tester dosaggi | 28-153 | Mixing glasses | 164 | Spazoloni pizzeria | 94-95-99-101-102 |
| Cannucce | 184 | Molle | 12→17-32-114-142-152 | Spatole per gelato | 22 |
| Cappelli cuoco | 127 | "Mollunghe" | 13 | Speed bottle | 179 |
| Caraffa | 183 | Morsa prosciutto base in legno | 65 | Speed racks | 177 |
| Carrello per mandolina | 67 | Mugs | 170-171 | Spicchio per casseruola | 47 |
| Casseruole alte | 34-36-38-42-44 | Oliera pizzeria | 105 | Spiedini inox | 65 |
| Casseruole basse | 34-36-38-42 | Padelle | 35-36-39-43-44 | Spremiagrammi manuale | 158 |
| Casseruola bassa antiaderente | 40 | Padelle antiaderenti | 35-37-40-43 | Sprenilimone | 160-173 |
| Casseruole bombate | 35-37-43 | Pala braci | 93-101 | Spumantiera | 175 |
| Casseruole medie | 34-36-38-42-44 | Pale e paletti pizzeria | 88→93-98→103 | Stampi pasticceria | 128→131-134 |
| Casseruole medie antiaderenti | 40 | Pala e palettino pizzeria smontabili | 96 | Stampi semifreddo | 127 |
| Centrifuga | 193 | Pale e paletti pizzeria Gluten Free | 100 | Steady Spout | 29-154 |
| Cestelli lavastoviglie | 76-77 | Pale pasticceria e gastronomia | 139→141-144 | Tagliabiscotti | 123→126 |
| Cestini | 185 | Palette | 52-54-57-59-110 | Tagliapasta | 58-110-121-122→125 |
| Chinois | 47 | Pennelli pasticceria | 122 | Tagliatartufi | 149 |
| Colini | 30 | Pentole | 35-36-39 | Taglieri | 75-181 |
| Colino per cocktail | 159-163 | Pestelli | 168 | Tappeti bar | 181 |
| Colonne per secchiello | 175 | Pettine per decorazione pasticceria | 132 | Tappi versatori | 24→29-152→154 |
| Coltelli cucina | 68→74 | Plastra per cialde cono | 196 | Tazzoni | 48 |
| Coltelli tavola | 138→142 | Piastre per waffle | 197 | Tegami | 35-37-39-43-44 |
| Contentore palline pasta per pizza | 105 | Piatti espositori | 66 | Tegame antiaderente | 40 |
| Coperchi pentolame | 35-36-39-43-44 | Pinze | 14-15-115 | Teglie | 50-51-106-107 |
| Coperchi gastronorm | 80-82-83 | Placca per forno | 50-106 | Teglia Gastronorm | 79 |
| Cucchiaini miscelatori | 169 | Planetaria | 192 | Timballo per dolci | 48 |
| Cucchiaini | 138→141 | Poggiaavassoio | 184 | Tirabrai | 95-101 |
| Cucchiaini bibita | 140-145-155-159 | Portaccondimenti | 176 | Tortiere | 51-107-128-130-131 |
| Cucchiaini | 52-54-56-57-105-140-141-145 | Portacucchiaini | 159 | Tostapane | 195 |
| Cucchiaini tavola | 138→142 | Portapale | 104 | Tronchetto tagliapizza | 59-111 |
| Cuocithé | 160 | Portaoggetti da bar | 180 | Vaporizzatori cocktail | 173 |
| Cutter tagliaverdure | 190-191 | Portastecchi | 148 | Vaschetta lavaggio dosatori gelato | 159 |
| Dash bottles | 173 | Portatovaglioli | 160-176-184 | Vassoi | 146-147-156-157 |
| Decora limone | 63-155 | Portavivande | 66 | Versus | 178-179 |
| Disidratatore alimenti | 194 | Portazucchero | 184 | Wok antiaderente | 35-37 |
| Dispenser in polietilene | 183 | Porzionatori gelato | 20-21 | | |
| Falso fondo forato per GN | 80-82-83 | Posacenere | 182 | | |
| Fermo per taglieri | 75 | Posate insalata | 140-145 | | |
| Flair bottle | 182 | Pressa per panini gelato | 196 | | |
| Forbici taglia pizza | 111-149 | Raccoglibriciole | 177 | | |
| Forchetta per ostrica | 145 | Raschie | 59-110-122 | | |
| Forchetta scavino per aragosta | 145 | Rete protettiva per bar | 181 | | |
| Forchette tavola | 138→142 | Riga limone | 63-155 | | |
| Forchettina per lumache | 145 | Robot da cucina | 190-191 | | |
| Forchettoni | 52-54-56-140-141 | Rompighiaccio manuale | 168 | | |
| Formaggiera in filo | 148 | Rompighiaccio elettrico | 168 | | |
| Friggitrice doppia | 195 | Rostiera rettangolare alta | 38 | | |
| Frullatori | 186-187 | Rotella taglia pasta | 122 | | |

| | | | | | |
|--------------------------------|-------------------|---|-----------------------------|---------------------------------------|---------------------------|
| Adaptor bar for GN | 80 | Graduated bucket | 51 | Pizza wheel cutters | 59-111-121-149 |
| All-purpose scoop | 126-168-174 | Graters | 60-62-67-149 | Pizzeria brushes | 100-101 |
| Apple corer | 63 | Ham vice | 65 | Pizzeria oil cruet | 105 |
| Ashtrays | 173-187-193 | Hand held knife sharpener | 74 | Planetary mixer | 192 |
| Bain marie pot | 48 | Hats | 127 | Plastic box for dough | 103 |
| Baking tray | 50-51-106-107 | Heating liquid for chafing dish | 157 | Plastic cruets | 187 |
| Baking plate | 50-106 | Ice-breaker - electric | 168 | Plastic grill for decorated biscuit | 133 |
| Bar mats | 181 | Ice-breaker - manual | 168 | Polyethylene dispenser | 183 |
| Bar organizer | 180 | Ice bucket | 174 | Pourers | 24-29-152-154 |
| Rackets | 185 | Ice-cream container | 23 | Protection mesh for bar | 181 |
| Belgian waffle makers | 197 | Ice-cream sandwich press | 196 | Removable pizza peel and turning peel | 96 |
| Beverage spoons | 140-145-155-159 | Ice-cream scoop | 20-21 | Removable rotatable oven brush | 96 |
| Biscuit cutter | 123-126 | Ice-cream server | 22 | Roaster | 38 |
| Blades for vegetable slicer | 67 | Jiggers | 159-166-167 | Roller cutter | 122 |
| Blenders | 186-188 | Juice extractors | 193 | Safety guard | 67 |
| Boston shakers | 162 | Kitchen bowl | 48 | Salad servers | 140-145 |
| Bottle-openers | 160-174 | Knife sharpener | 192 | Sauce ladle | 140-145 |
| Bowl | 49 | Knives | 68-74 | Scissor servers | 14-15-115 |
| B-Pour pour check | 28-153 | Ladles | 52-54-56-140 | Scrapers | 59-110-122 |
| Bread cutter | 67 | Large spoon | 52-54-56-57-105-140-141-145 | Semifreddo moulds | 127 |
| Butchery hooks | 64 | Lemon decorator | 63-155 | Shakers | 164-165 |
| Butter curler | 63 | Lemon grater | 63-155 | Shallow cookpots | 34-36-38-40-42 |
| Butter spreader | 140-142 | Lemon squeezer | 160-173 | Shallow saucepan | 34 |
| Cake mould | 128-131-134 | Lids for pots and pans | 35-36-39-43-44 | Sieves | 49 |
| Cake stand | 132-134 | Lid for gastronorm | 80-82-83 | Skewers | 65 |
| Carafe | 183 | Lifters | 52-54-57-59-110 | Skimmers | 52-54-56 |
| Carving and decoration set | 77-165 | Lobster pick | 145 | Snail fork | 145 |
| Champagne bowl | 175 | Long handle strainer | 61 | Spatulas | 55-58-109-110-120-121-132 |
| Charcoal shovel | 93-101 | Measuring jug | 48-127 | Speed bottle | 179 |
| Cherry ladles | 158 | Meat beater | 64 | Speed racks | 177 |
| Chinois | 47 | Meat fork | 52-54-56-140-141 | Spice grinder | 191 |
| Chopsticks | 149 | Medium cookpots | 34-36-38-40-42 | Spirits measure | 190 |
| Chopstick rest | 149 | Medium saucepans | 34-36-38-40-42 | Stand for bucket | 185 |
| Citrus fruit squeezer - manual | 158 | Melon baller | 63-155 | Steady Spout | 29-154 |
| Coaster | 160 | Milk jug | 158 | Stirring spoon | 159 |
| Cocktail atomizer | 173 | Mixers | 188-189 | Stopper for cutting boards | 75 |
| Cocktail strainer | 159-163 | Mixing glasses | 164 | Strainer for deep cookpot | 47 |
| Cocoa sprinkler | 158 | Mixing spoon | 169 | Strainers | 30 |
| Compact panini grill | 203 | Moka spoon | 138-141 | Straws | 184 |
| Condiment set | 148 | Moka spoon holder | 159 | Sugar bowl | 184 |
| Cruets | 176 | "Mollunga" tongs | 13 | Syphons | 177 |
| Crumb sweepers | 187 | Mugs | 180-181 | Vegetable peeler | 67 |
| Curved saute pans | 35-37-43 | Napkin-holder | 160-176-184 | Table fork | 138-142 |
| Cutting boards | 75-181 | Nozzles brush | 117 | Table knife | 138-142 |
| Dash bottles | 173 | Orange peeler | 63-155 | Table spoon | 138-142 |
| Decorating nozzles | 117-119 | Order rack | 177 | Tea infuser | 160 |
| Deep cookpots | 34-36-38-42-44 | Oven brushes | 94-95-99-101-102 | Thermal circulator | 194 |
| Deep fryer | 195 | Oven rake | 95-101 | Toaster | 195 |
| Deep saucepans | 34-36-39-40-42 | Oyster fork | 145 | Tongs | 12-17-32-114-142-152 |
| Dishwasher racks | 76-77 | Panini grill | 195 | Toothpicks holder | 148 |
| Display tray | 66 | Pans | 35-36-39 | Trays | 146-147-156-157 |
| Electric ice-cream maker | 193 | Parmesan cheese cellar | 148 | Tray rest | 184 |
| Falling handles for GN | 80 | Pasta strainer | 49 | Truffle-slicer | 149 |
| Firedog | 105 | Pasta warmer | 47 | Two-handed frying pans | 35-37-39-40-43-44 |
| Flair bottle | 182 | Pastry bags | 116-118 | Vegetable dish | 152 |
| Flat rack | 127-133 | Pastry brushes | 122 | Vegetable slicer | 63 |
| Flexible desk cleaner | 104 | Pastry comb for decoration | 132 | Versus | 178-179 |
| Food carrier | 66 | Pastry cutter | 58-110-121-122-125 | Waffle cone maker | 196 |
| Food dehydrator | 194 | Pastry moulds | 127-136-141 | Wall mounted peel rack | 103 |
| Food processors | 190-191 | Pastry wheel cutter | 120 | Whisks | 62 |
| Frying pans | 35-36-39-40-43-44 | Peel holder | 104 | Wine buckets | 175 |
| Gastronorm baking pan | 79 | Pestles | 168 | Wok with non-stick coating | 35-37 |
| Gastronorm drainer plate | 80-82-83 | Pie mould | 48 | | |
| Gastronorm in plastic | 82 | Pie servers | 139-141-144 | | |
| Gastronorm in polypropylene | 83 | Pizza boards | 93 | | |
| Gastronorm in stainless steel | 78-79 | Pizza chef travel bag | 97 | | |
| Glasses | 164-183 | Pizza cutter | 59-111 | | |
| Glass for boston shaker | 163 | Pizza peels and turning peels | 88-93-98-103 | | |
| Glass rimmer | 180 | Pizza peels and turning peels Gluten Free | 100 | | |
| Gloves | 62 | Pizza scissors | 111-149 | | |

SUPPORTO VENDITA

SALES SUPPORT ITEMS

Cod. X0100

CATALOGO PIAZZA
 PIAZZA CATALOGUE

Cod. X0101

LISTINO PIAZZA (PDF)
 PIAZZA PRICE LIST (PDF)

Cod. X0118

CATALOGO PIAZZA-ATLANTIC CHEF (PDF)
 PIAZZA-ATLANTIC CHEF CATALOGUE (PDF)

Cod. X0119

CATALOGO PIZZERIA COLLEZ. PUNTOROSSO (PDF)
 PIZZERIA CATALOGUE PUNTOROSSO COLLEC. (PDF)

Cod. X0246

VOLANTINO PENTOLE ALLUMINIO (PDF)
 ALUMINUM POTS AND PANS FLYER (PDF)

Cod. X0247

VOLANTINO GRATTOGIE PROFESSIONALI (PDF)
 PROFESSIONAL GRATER FLYER (PDF)

Cod. X0248

VOLANTINO MOLLE NYLON+FIBERGLASS (PDF)
 NYLON+FIBERGLASS TONGS FLYER (PDF)

Cod. X0249

VOLANT. MESTOLAME NYLON+FIBERGLASS (PDF)
 NYLON+FIBERGLASS KITCHEN TOOLS FLYER (PDF)

Cod. X0250

BROCHURE "UNA STORIA DI QUALITÀ" (PDF)
 'HISTORY OF QUALITY' BROCHURE (PDF)

Cod. X0330

CATALOGO HAPPY HOUR (PDF)
 HAPPY HOUR CATALOGUE (PDF)

Cod. X0344

BROCHURE COLLEZIONE MOLLE (PDF)
 TONGS COLLECTION BROCHURE (PDF)

Cod. X0345

DEPLIANT STEADY SPOUT 2.0 (PDF)
 STEADY SPOUT 2.0 LEAFLET (PDF)

Cod. X0347

DEPLIANT PORZIONATORE NYLON+FIBERGLASS (PDF)
 NYLON+FIBERGLASS ICE-CREAM SCOOP LEAFLET (PDF)

Cod. X0349

DEPLIANT COLLEZIONE PENTOLE "3-PLY" (PDF)
 POTS AND PANS '3-PLY' COLLECTION' LEAFLET (PDF)

Cod. X0350

DEPLIANT COLLEZIONE PENTOLE "PROCHEF" (PDF)
 POTS AND PANS 'PROCHEF' COLLECTION LEAFLET (PDF)

X0100



X0101



X0118



X0119



X0246



X0247



X0248

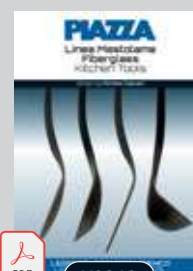

X0249

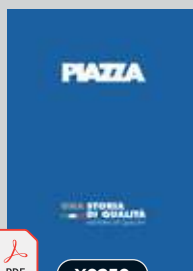

X0250

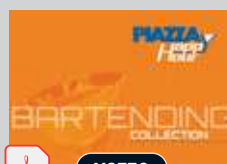

X0330

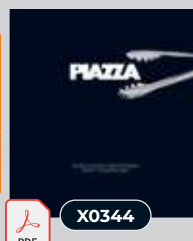

X0344



X0345



X0347



X0349



X0350



QUESTO SIMBOLO INDICA CHE I MATERIALI SONO
 DISPONIBILI SOLO IN FORMATO DIGITALE (FILE PDF)
 THIS SYMBOL INDICATES THAT THE MATERIALS
 ARE AVAILABLE ONLY IN DIGITAL FORM (PDF FILE)

SCOPRI IL
 NOSTRO SITO
 DISCOVER OUR
 WEBSITE



SFOGLIA IL NOSTRO
 CATALOGO
 BROWSE OUR
 CATALOGUE



TABELLE CONVERSIONE

CONVERSION TABLES

LUNGHEZZA LENGTH

| | | |
|-------------|------------|--------|
| 0,30 | 1 | 3.28 |
| 0,61 | 2 | 6.56 |
| 0,91 | 3 | 9.84 |
| 1,22 | 4 | 13.12 |
| 2,52 | 5 | 16.40 |
| 1,83 | 6 | 19.68 |
| 2,13 | 7 | 22.96 |
| 2,44 | 8 | 26.25 |
| 2,74 | 9 | 29.53 |
| 3,05 | 10 | 32.81 |
| 6,10 | 20 | 65.62 |
| 15,24 | 50 | 164.05 |
| 30,50 | 100 | 328.10 |

METRI
METERS

PIEDI
FEET

| | | |
|--------------|------------|-------|
| 2,54 | 1 | 0.39 |
| 5,08 | 2 | 0.79 |
| 7,62 | 3 | 1.18 |
| 10,16 | 4 | 1.58 |
| 12,70 | 5 | 1.97 |
| 15,24 | 6 | 2.36 |
| 17,78 | 7 | 2.80 |
| 20,32 | 8 | 3.16 |
| 22,86 | 9 | 3.55 |
| 25,40 | 10 | 3.94 |
| 50,80 | 20 | 7.88 |
| 127,00 | 50 | 19.70 |
| 254,00 | 100 | 39.40 |

CENTIMETRI
CENTIMETERS

POLLICI
INCHES

PESO WEIGHT

| | | |
|--------|------------|------|
| 28,3 | 1 | 0.04 |
| 56,7 | 2 | 0.07 |
| 85,0 | 3 | 0.10 |
| 113,4 | 4 | 0.14 |
| 141,8 | 5 | 0.18 |
| 170,1 | 6 | 0.21 |
| 198,4 | 7 | 0.25 |
| 226,8 | 8 | 0.28 |
| 255,2 | 9 | 0.32 |
| 283,5 | 10 | 0.35 |
| 567,0 | 20 | 0.71 |
| 1417,5 | 50 | 1.76 |
| 2835,0 | 100 | 3.53 |

GRAMMI
GRAMS

ONCE
OUNCES

| | | |
|-------|------------|--------|
| 0,45 | 1 | 2.21 |
| 0,91 | 2 | 4.41 |
| 1,36 | 3 | 6.62 |
| 1,81 | 4 | 8.82 |
| 2,27 | 5 | 11.02 |
| 2,72 | 6 | 13.23 |
| 3,18 | 7 | 15.43 |
| 3,63 | 8 | 17.64 |
| 4,09 | 9 | 19.84 |
| 4,54 | 10 | 22.05 |
| 9,07 | 20 | 44.09 |
| 22,68 | 50 | 110.20 |
| 45,36 | 100 | 220.50 |

CHILOGRAMMI
KILOGRAMS

LIBBRE
POUNDS

CAPACITÀ CAPACITY

| | | |
|--------|------------|-------------|
| 3,79 | 1 | 0.26 |
| 7,57 | 2 | 0.53 |
| 11,35 | 3 | 0.79 |
| 15,14 | 4 | 1.06 |
| 18,93 | 5 | 1.32 |
| 22,71 | 6 | 1.58 |
| 26,50 | 7 | 1.85 |
| 30,28 | 8 | 2.11 |
| 34,16 | 9 | 2.38 |
| 37,94 | 10 | 2.64 |
| 75,88 | 20 | 5.28 |
| 189,70 | 50 | 13.20 |
| 379,40 | 100 | 26.40 |

LITRI
LITERS

GALLONI USA
USA GALS

| | | |
|-------|-------------|-------------|
| 1,50 | 0,5 | 0.16 |
| 2,25 | 0,75 | 0.25 |
| 3,00 | 1 | 0.33 |
| 4,50 | 1,5 | 0.50 |
| 6,00 | 2 | 0.66 |
| 7,50 | 2,5 | 0.83 |
| 9,00 | 3 | 1.00 |
| 10,50 | 3,5 | 1.16 |
| 12,00 | 4 | 1.33 |
| 13,50 | 4,5 | 1.50 |
| 15,00 | 5 | 1.66 |
| 16,50 | 5,5 | 1.83 |
| 18,00 | 6 | 2.00 |

CENTILITRI
CENTILITERS

ONCE
OZS

TEMPERATURA TEMPERATURE

| | | |
|-------|------------|--------|
| -40,0 | -40 | -40.0 |
| -28,8 | -20 | -4.0 |
| -23,3 | -10 | +14.0 |
| -17,7 | 0 | +32.0 |
| -12,2 | 10 | +50.0 |
| -6,6 | 20 | +68.0 |
| +2,7 | 37 | +98.6 |
| +4,4 | 40 | +104.0 |
| +10,0 | 50 | +122.0 |
| +37,7 | 100 | +212.0 |

CELSIUS

FAHRENHEIT



PIAZZA

PIAZZA EFFEPI s.r.l.

Sede Legale

Corso Buenos Aires, 64 Scala D
20124 Milano (MI) - ITALY

Sede Operativa

via Fratelli Cairoli, 1
28887 Omegna (VB) - ITALY
Tel. +39 0323 6605 r.a.
Mail. piazza@piazza.it
Web. www.piazza.it

